

BUTTERFLY VALVES-HIGH PERFORMANCE & LINED

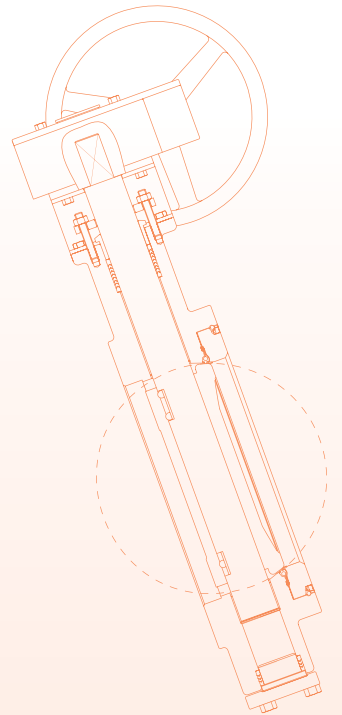

SHORT VERSION

[Click here](#) for complete version of this catalogue



API 607 6th & 7th Ed.
& ISO 10497-5
Firesafe Certified



**AUSTRALIAN
PIPELINE VALVE®**

www.australianpipelinevalve.com.au

QUALITY VALVE MANUFACTURER

QUALITY COMMITMENT

Quality is Our First Priority.

Consistent product quality and a proven track record makes Australian Pipeline Valve a dependable choice where total reliability is the number one concern.

Since its founding, APV's philosophy has been focused on quality. Our valves are manufactured in full compliance to worldwide standards (such as ASME/ANSI, API, EN, ISO, BS, AS).

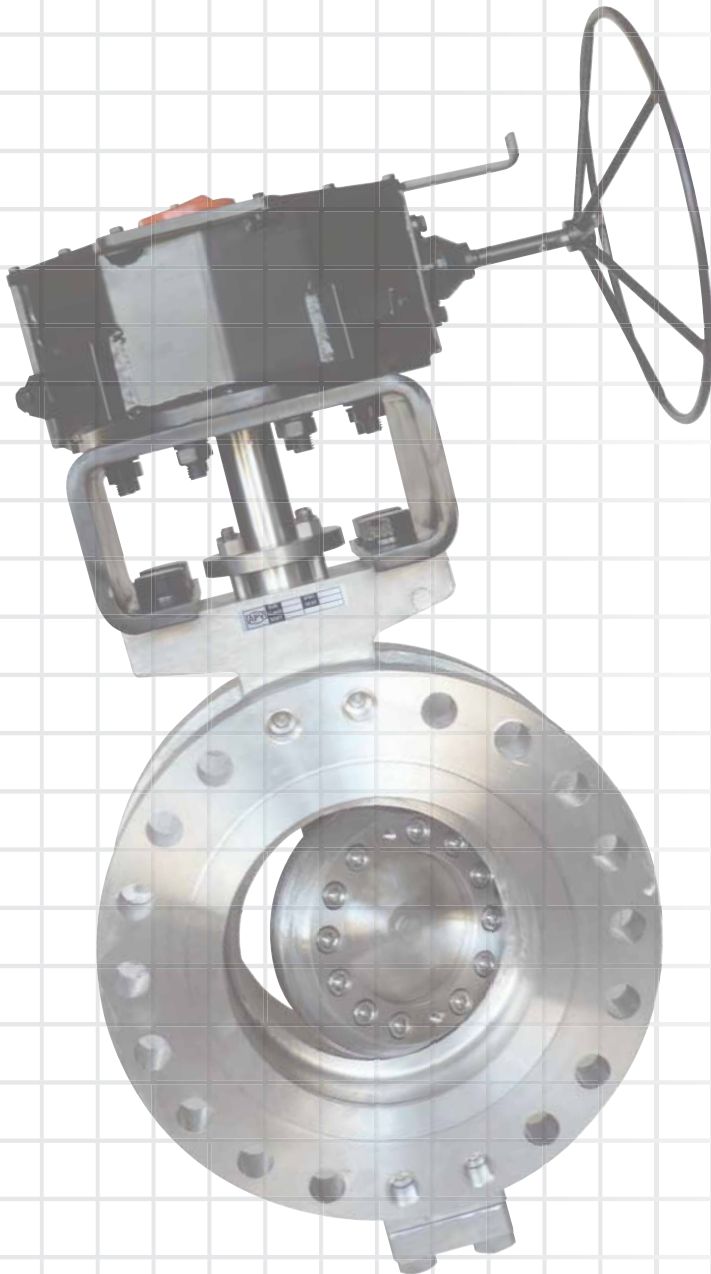

**AUSTRALIAN
PIPELINE VALVE®**

70-78 Stanbel Road Salisbury Plain South Australia 5109
Telephone +61 (0)8 8285 0033 Fax +61 (0)8 8285 0044
email: admin@australianpipelinevalve.com.au

CONTENTS

High Performance Double Offset	4~9
High Performance Triple Offset	10~19*
Figure Number System - Double Offset and Triple Offset Butterfly Valves	20
Lined 2014/2016 Series	21~25*
Lined 2014/2016 HP Series	26~30*
Lined 2014/2016 HP2 Series	31*
Lined 2014 2P Series	32~36*
PTFE/FEP/PFA/ETFE Lined Butterfly Valve Model 2014-2P-D0	37~38*
Large Diameter Flanged Butterfly Valve HU-B60 Series	39~41*
Large Diameter Flanged Butterfly Valve HU-B70 Series	42~46*
Screwed Ends Butterfly Valve 14 Bar	47*

* This version excludes some of these pages, refer to full version at website.



© Copyright Australian Pipeline Valve 1990 - 2023 Edition

Catalogues, photos, brochures and technical publications are the exclusive property of Australian Pipeline Valve. Any unauthorised reproduction in total or in part, shall result in prosecution. Products and data sheets in this publication are subject to change at anytime without notice. Australian Pipeline Valve reserves the right to carry out amendments to products and materials.

DOUBLE OFFSET BUTTERFLY VALVES

MODEL SLHBF, SLHBFFS 150 TO 1500 CLASS DOUBLE OFFSET

RANGE & STANDARDS

Size	50NB - 1800NB (2" to 72")
Class	150 to 1500 ANSI
General Design	API 609 (Cat B) & ASME B16.34
Design Standards	Flanged MSS-SP-67 Wafer MSS-SP-68/ API 609-B Wall Thickness API 609
Construction	Wafer, lugged, flanged
Pressure/ Temp.	ASME B16.34 & API 609-B / ISO 5752
Face to Face	ASME B16.10 short / MSS-SP-67 / MSS-SP-68/ API 609-B/ ISO 5752 short
Flange Dimensions	ASME B16.5, over 600NB (24") - MSS-SP-44 or API 605 or ASME B16.47, AS 4331.1, ISO 7005-1, E1092-1 PN10 ~ 250 also available
Pressure Test	API 598, ISO 5208, EN 1266, MSS-SP67
Leakage Rates	FCI 70-2 Class VI up to zero leakage API 598 / ISO 5208
Temperature Range	Resilient Seal (Soft) -46°C to 220°C (-50°F to 428°F) Metal Seal -46°C to 900°C (-50°F to 1652°F)



API 622 & ISO 15848-1
Endurance Test Certified



API 607 6th & 7th Ed.
ISO 10497-5
Firesafe Certified



API 622 2011 2nd Edition
ISO 15848-2
Fugitive Emission Certified



PRINCIPLES OF VALVE DESIGN

The standard SLHBF/SLHBFFS design is double offset (double eccentric). Available in firesafe & non firesafe in soft and metal seated. The soft seated version incorporates a metal seat retainer with an RPTFE insert for high pressure service and long life.

The basic concept of the SLHBF/SLHBFFS is to only utilise a thin slice of a ball valve at the seat ring area. The body is only wide enough to hold the disc, shaft & seat in place, all the remaining material is eliminated because it serves no purpose. Ball valves have 2 seats, but floating balls only seal on the upstream seat hence the sealing effectiveness of a HP Butterfly Valve is the same. The disc seating edge is a segment of a sphere and creates a reliable, high pressure seal against an un-interrupted 360° seat sealing surface. The disc profile is very thin & allows maximum flow with a low pressure drop.

The most common use of the SLHBF/SLHBFFS is to shut-off flow inside a pipeline. Every component of the valve is designed to contribute to this goal. The disc, shaft, bearings, packing & disc pins all work together to ensure that the disc is accurately positioned when closed to allow the seat to energise to the disc & create a seal.



DOUBLE OFFSET BUTTERFLY VALVES

MODEL SLHBF, SLHBFFS 150 TO 1500 CLASS DOUBLE OFFSET

FEATURES - DOUBLE OFFSET

The SLHBF Range is based on a unique quarter-turn design. The double offset shaft and disc configuration together with the advanced high technology seat system provides a reliable rugged multi-purpose butterfly valve range.

At the point of the disc opening, the double offset disc provides a cam-like action, thus preventing excessive seat wear & ensuring a long maintenance free life.

- Seat removal is possible without disassembly of the shaft and disc.
- Body insert protects seat from abrasion and erosion.
- Graphoil or PTFE seal-ring & packing.
- 2 Piece stem for extra flow.

Actuator bracket according to ISO 5211, which allows replacement of the stem seals without removal of the actuator.



PTFE-Seat System - SLHBF/SLHBFFS

In the preferred flow-direction, the PTFE-Seat system provides optimum performance. In this design, the line pressure acts as a positive force in the seat system even in fluctuating working conditions. The seat ring is retained by a metal seat retainer and is well protected by the valve-body, thus preventing seat distortion.

Bi-directional* - SLHBF/SLHBFFS

The primary PTFE-seat ring is backed up by a secondary metal ring. This metal seat provides a mechanical load to energize the PTFE-seat. The metal sealing ring secures and encapsulates the PTFE ring to ensure rigidity. In combination with the line pressure a Bi-directional* sealing against the line pressure is obtained.

* Bi-directional flow, however, bi-directional leak tight shut off must be specified with order.

Fire Safe - SLHBFFS

The model SLHBFFS has a secondary metal seat which gives bi-directional sealing in the event of the PTFE seat insert being burned away in a fire.

Metal to Metal Seat - SLHBF/SLHBFFS

High temperature service and Abrasive service. Bi-directional and inherently firesafe design.

The primary metal seal enables this execution to be used up to 670°C. Seat-rings available are stainless steel ANSI 316L-chromium plated, (maximum allowed temperature: 310°C) and Inconel 625 (maximum allowed temperature: 760°C). As a result the Metal to Metal range meets the full pressure and temperature rating according to ANSI class ratings. Seat leakage can be specified to API 598 (ISO 5208 Leakage Class A), API 6D, FCI 70-2 Class VI etc.

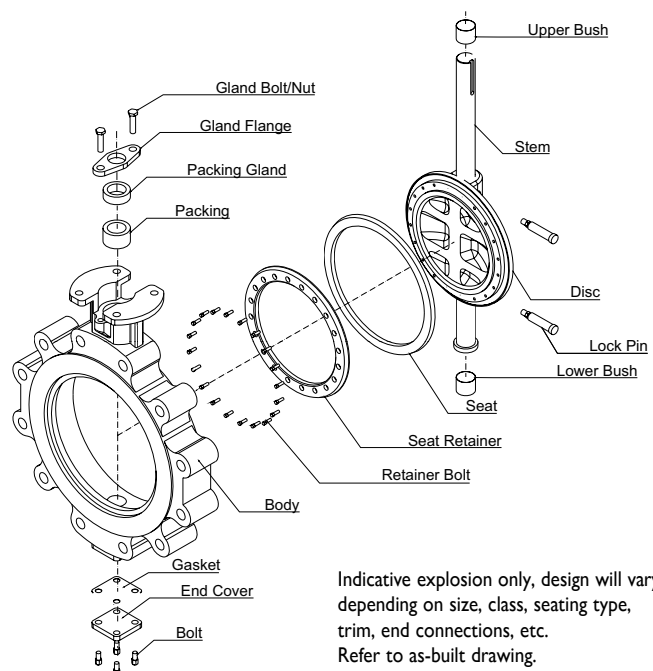

Indicative explosion only, design will vary depending on size, class, seating type, trim, end connections, etc. Refer to as-built drawing.

SEATING STYLES DOUBLE OFFSET

METAL TO METAL SEAT (FLEXIBLE FLO-SEAL STYLE)

(SOLID ENERGISED STYLE)

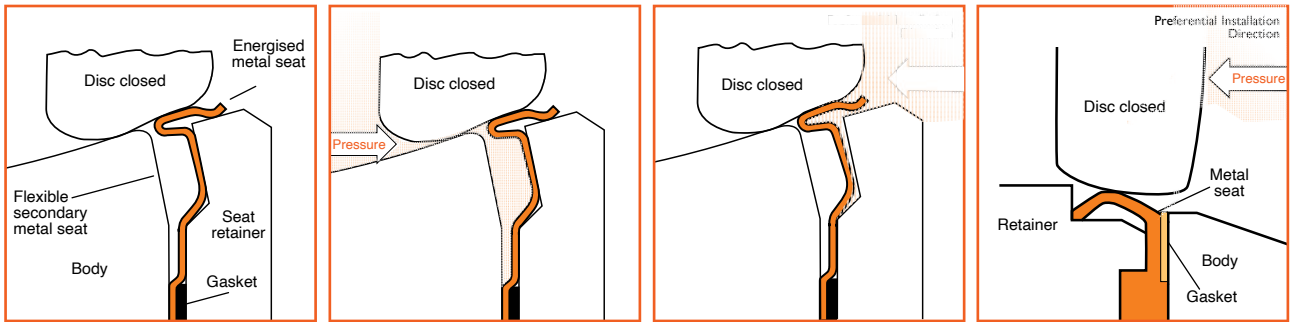

FIRESAFE SOFT SEAT (ENERGISED FLO-SEAL STYLE)

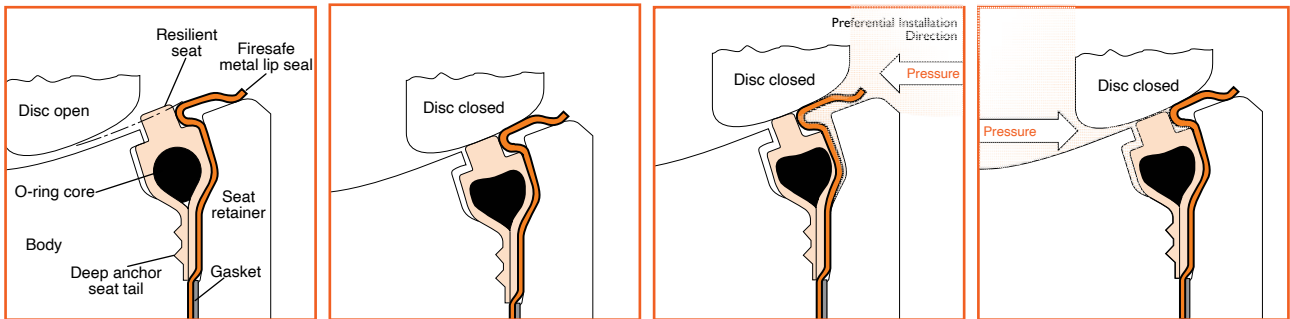

SOFT SEAT (ENERGISED FLO-SEAL STYLE)

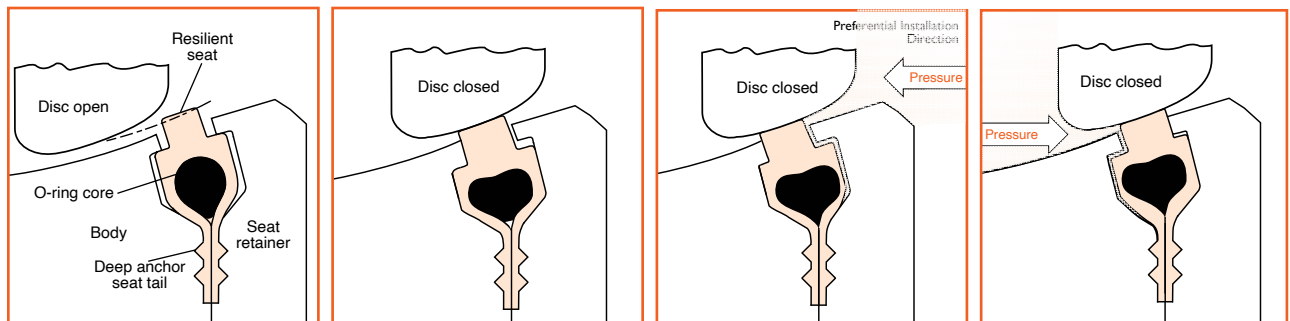

SOFT SEAT (ENERGISED LIP-SEAL STYLE)

(FIRESAFE ENERGISED LIP-SEAL STYLE)

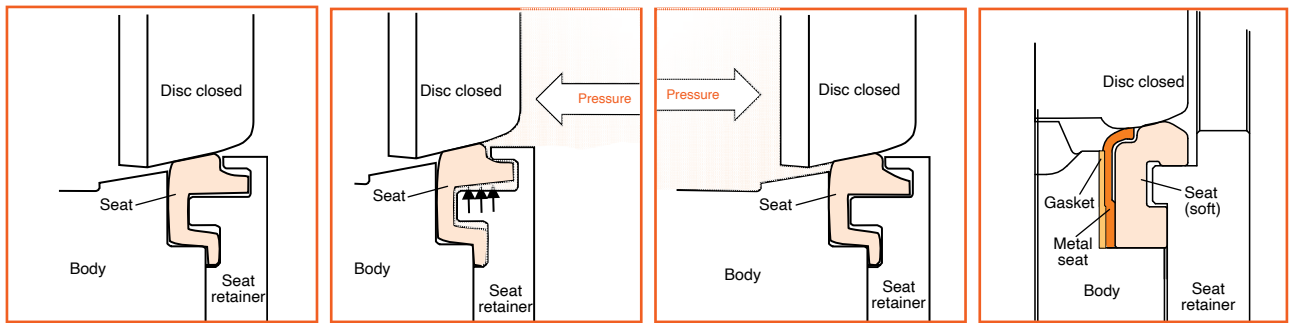

Actual drawing supplied on request. Indicative drawings only.

SLHBFFS/SLHBF DOUBLE OFFSET WAFER & LUG DIMENSIONS

APPLICABLE STANDARDS

Mounting Pad	ISO 5211
End Flange	ANSI B16.5
Wall Thickness	ANSI B16.34
Face to Face	MSS SP-68/ API 609
Pressure Temperature Rating	B16.34
Design	API 609-B

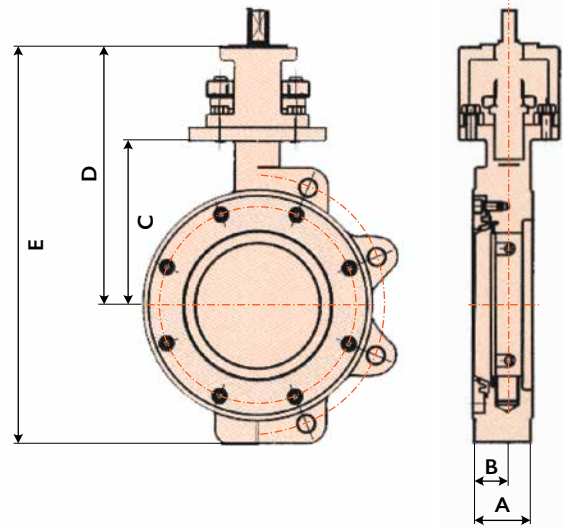

DIMENSIONS (MM) 150LB & PN25

Size mm	80	100	150	200	250	300	350	400	450	500	600
Size inch	3"	4"	6"	8"	10"	12"	14"	16"	18"	20"	24"
A	48.0	54.0	57.0	63.5	71.5	81.0	92.0	101.5	114.5	127.0	154.0
B	27.3	30.6	33.9	40.5	41.8	48.0	56.5	63.0	71.5	79.0	90.5
C	113.0	132.0	162.0	192.0	262.0	298.0	320.0	365.0	388.0	418.0	498.0
D	183.4	202.5	245.3	289.0	364.0	401.5	420.0	482.0	510.0	535.0	679.0
E	256.4	309.6	375.8	470.4	585.2	660.6	710.6	800.6	876.5	930.4	1302.7
ISO 5211 MOUNTING PAD	F07	F07	F10	F10	F10	F14	F14	F14	F16	F16	F25

Dimensions indicative only, refer drawing.

WEIGHT (KG)

Lug	5.5	15.5	21	36	45	69	95	162	216	242	554
Wafer	9.5	11	16	27	30	45	68	120	168	195	433

DIMENSIONS (MM) 300LB

Size mm	80	100	150	200	250	300	350	400	450	500	600
Valve Size	3"	4"	6"	8"	10"	12"	14"	16"	18"	20"	24"
A	48.0	54.0	59.0	73.0	82.5	92.0	117.5	133.5	149.5	159.0	181.0
B	27.3	30.6	33.9	40.5	50.3	59.0	60.5	72.5	81.5	94.0	116.5
C	123.0	138.0	183.0	213.6	282.0	324.0	340.0	369.0	421.4	458.6	552.0
D	193.4	206.0	265.5	311.0	384.0	427.5	446.0	501.0	548.5	581.0	690.0
E	292.4	321.0	416.6	514.8	626.7	708.7	731.8	816.4	962.0	1053.5	1414.6
ISO 5211 MOUNTING PAD	F07	F07	F10	F10	F10	F14	F14	F14	F16	F16	F25

Dimensions indicative only, refer drawing. 600 to 2500 Class refer to drawing.

WEIGHT (KG)

Lug	15.5	24	36	54	79	117	253	329	504	649	986
Wafer	10	13	19	32	39	55	167	195	325	407	632

SLHBF/FS-150 / SLHBF/FS-300 DOUBLE OFFSET ASSEMBLY DRAWING

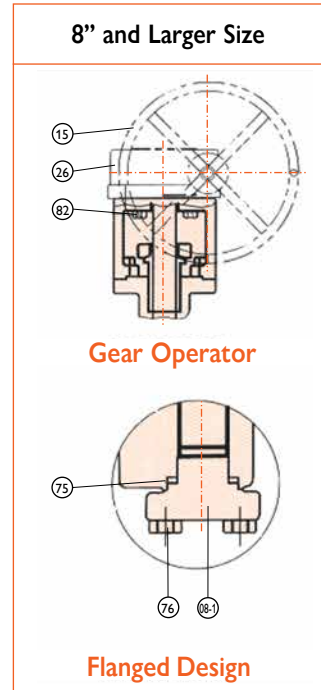
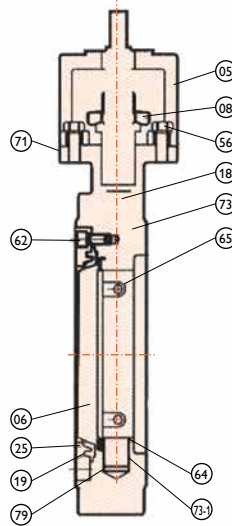
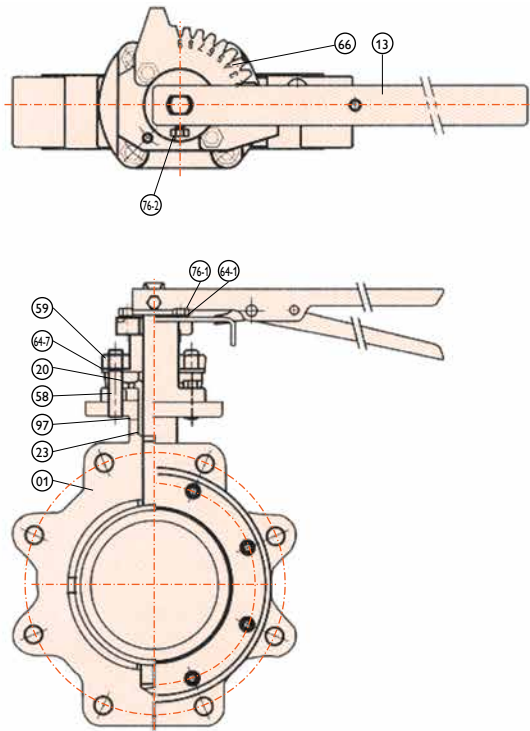

PARTS LIST

150LB & 300LB

No.	Description	Material	QTY.	No.	Description	Material	Qty.
01	Body	A351 CF8M / A216 WCB	1	62	Wrench Bolt	A193 B8M / B8	1 SET
05	Yoke	A351 CF8 / A216 WCB	1	64	Disc Washer	A276 316 / 304	2
06	Disc	A351 CF8M	1	64-1	Lock Washer	Stainless Steel	2
08	Gland Flange	A351 CF8 / A105	1	64-2	Spring Washer	Stainless Steel	2
08-1	Low Gland Flange	A351 CF8M / A216 WCB	1	65	Disc Pin	316 / 17-4 PH / 304	2
13	Lever	Carbon Steel	1	66	Stopper	Carbon Steel	1
15	Handwheel (Gear)	Carbon Steel	1	71	Name Plate	Stainless Steel	1
18	Stem	17-4 PH / 316 / 304	1	73	Stem Bearing	316 S/S Backed R.T.F.E.	1
19	Seat	R-PTFE / 316 / Stellite	1	73.1	Stem Bearing	316 S/S Backed R.T.F.E.	1
19a	Seat Metal Fire Seal	A276 316	1	75	O-Ring	PTFE / Graphite	1
20	Gland Ring	A276 316 / 304	1	76	Low Gland Bolt	A193 B8	1 SET
23	Spacer	A276 316 / 304	1	76-1	Setting Bolt	A193 B8	2
25	Seat Retainer	A351 CF8M / A105	1	76-2	Setting Bolt	A193 B8	1
26	Gear Box	Ductile Iron	1 SET	79	Disc Spring	Stainless S	1
56	Yoke Bolt	A193 B8	1 SET	82	Gear Bolt	A193 B8	1 SET
58	Gland Bolt	A193 B8	2	97	Packing	PTFE / GRP	1 SET
59	Gland Nut	A194 8	2	-	-	-	-

Indicative example only, design varies according to size, class and specifications. Refer to as-built drawing.

SLHBF & SLHBFFS DOUBLE OFFSET ENGINEERING DATA

PRESSURE/TEMPERATURE RATING 150/300 CLASS

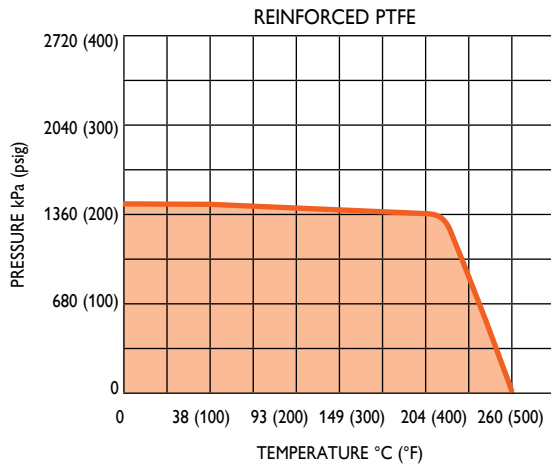

CV CURVE ANSI 150/300 CLASS

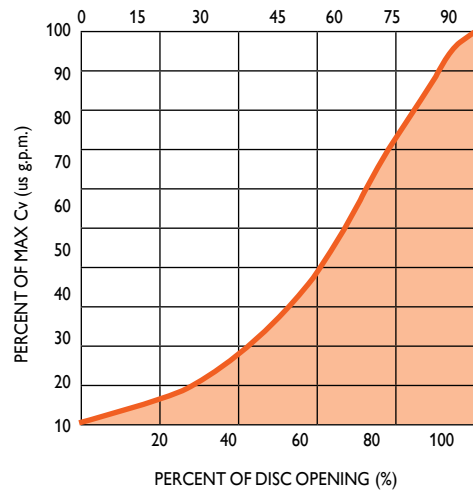

CV RATING ANSI 150 CLASS

Valve Size DN (NPS)	Cv
80 (3")	240
100 (4")	430
150 (6")	1150
200 (8")	2100
250 (10")	3200
300 (12")	4700
350 (14")	5160
400 (16")	6930
450 (18")	9330
500 (20")	11340
600 (24")	18540

150 CLASS BODY PRESSURE/TEMPERATURE RATING

Temperature °C	Carbon Steel	Stainless Steel 316	20# Alloy	Monel
-20 -38	19.7	19.0	15.8	15.8
93	17.9	16.5	13.8	13.8
149	15.8	14.8	12.4	13.1
204	13.8	13.4	11.0	12.8
260	11.7	11.7	10.3	11.7
Test Pressure	31.0	29.3	24.1	24.1

Indicative only, Refer Drawing.
Refer Data Sheet Class ≥ 300lb.

SLHBF - TORQUE RATING* 150/300 CLASS

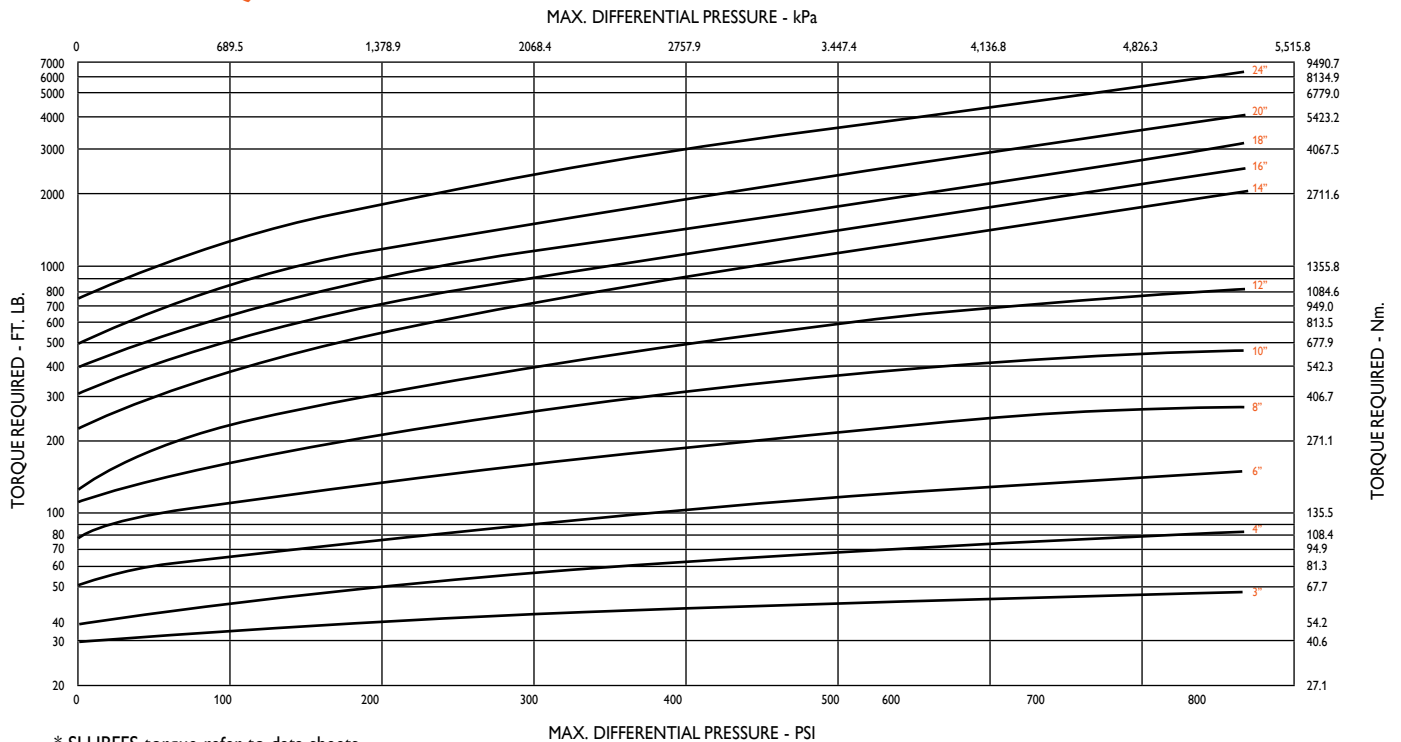

* SLHBFFS torque refer to data sheets.

TRIPLE OFFSET BUTTERFLY VALVES

MODEL SLHBFFS-T 150 TO 2500 CLASS TRIPLE OFFSET

RANGE & STANDARDS

Size	50NB - 1800NB (2" to 72")
Class	150 to 1500 ANSI
Design Standards	API 609 Category B & ASME B16.34
Dimensions	API 609-B/ ISO 5752/ MSS-SP-67/68
Construction	Wafer, lugged, flanged short & long pattern
Pressure/ Temp.	ASME B16.34 & API 609-B/ ISO 5752
Face to Face	ASME B16.10 short & long/ API 609/ API 6D/ ISO 5752 short
Flange Dimensions	ASME B16.5, over 600NB (24") - MSS-SP-44 or API 605 or ASME B16.47
Pressure Test	API 598, ISO 5208 Rate A, EN 1266, API 6D
Leakage Rates	True zero leakage



The SLHBFFS-T Range is based on a unique quarter-turn design. The Triple offset shaft and disc configuration together with the advanced high technology seat system provides a reliable rugged multi-purpose butterfly valve range. Bi-directional torque seated design. Hardened bearings for high cycle and long life.

Laminated/Metal Seat

The triple laminated design seat with multiple stainless steel seat rings laminated with graphite inserts to provide zero leakage. The SLHBFFS-T is suitable for high temperature and abrasive service. The laminated and all-metal seat design facilitates bi-directional high temperature service and is inherently firesafe design. The primary metal seat enables the execution to be used up to 670°C. Seat-rings available are Duplex (400°C), stainless steel ANSI 316L (500°C) or stellite (600°C) and Inconel 625 (760°C). As a result depending on seat selection the metal/laminated and solid seat range meets the full pressure temperature rating according to ASME class ratings. Seat leakage can be specified to API 6D/API 598 (ISO 5208 Zero Leakage Class A), FCI 70-2 Class VI etc.

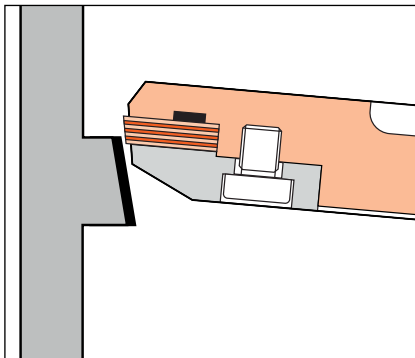

Disc slightly open

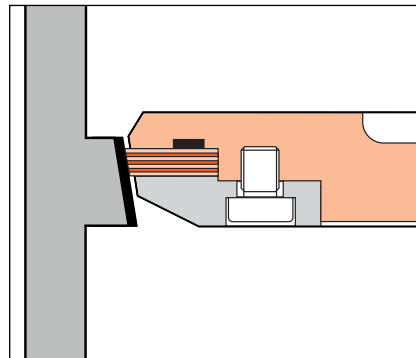

Disc closed: Multi layer seat ring

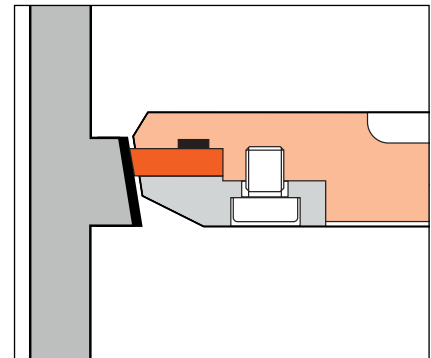

Disc closed: Pure metal seat ring

MODEL SLHBFFS-T 150 TO 2500 CLASS TRIPLE OFFSET

PRINCIPLES OF VALVE DESIGN - TRIPLE OFFSET

Superseal Model SLHBFFS-T 150 to 2500 Class triple offset metal seat butterfly valves provide a bi-directional and bubble-tight shut-off which is attributed to the geometry of the triple offset seat. Available in metal to metal and metal laminated graphite seat designs. Can also be used for flow control linear flow characteristics between 90 degrees and 70 degrees of opening.

The valve stem is offset from the seat area (1st offset) and the valve seat surface centre line is offset against the centre line of the pipe (2nd offset) and the conical axis is offset from the valve centre line (3rd offset: inclined cone). The 3rd offset completely eliminates rubbing or scraping. The seat surfaces of the body and seal ring in this triple offset design, contact with an inclined “cone-in-cone”, and this design requires precision seating tolerances and durability to ensure a slight precision lapped wedge-mating effect. In addition, the angle of contact between the body and seat ring provides a low opening and closing torque due to almost no wedging and no scraping action on opening or closing (unlike trunnion mounted ball valves). This eccentric triple offset design provides excellent sealing performance and seat durability and it hardly ever needs repair under normal service conditions.

The seat design can be all metal to metal (optional resilient metal seat design) or multiple laminated using resilient metal alternated with one or even two of the following laminations depending on service: - graphite/aramid fibre/ceramic fibre.

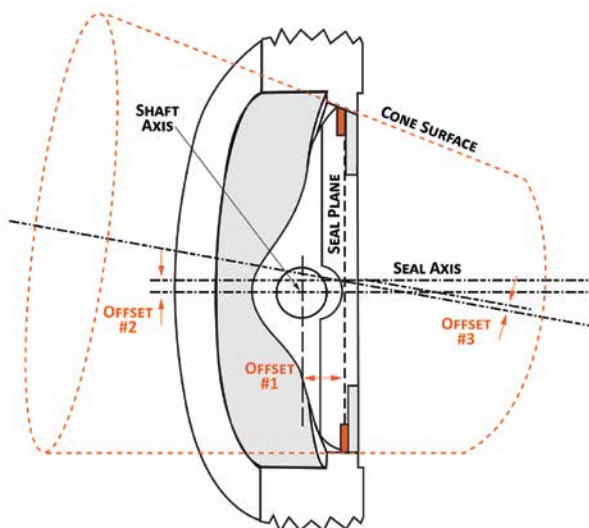

Triple Offset Design



DESIGN FEATURES - TRIPLE OFFSET

Characteristics and Merits

- Excellent seat durability and low operating torque due to non-rubbing characteristics of triple offset construction.
- Bi-directional zero leakage service available (when specified).
- Unrestricted selection of face to face dimensions for API, ASME (ANSI), EN, ISO etc. & perfect interchangeability of gate, ball, plug, high performance butterfly, & other valves.
- Low emission design, quarter turn construction, low operating torque & lower cost.

Leakage Rates

Leakage rates range from FCI-70 Class IV, V or VI through to zero leakage. Valves can be specified to:-

- API 598 Zero Leakage
- ISO 5208 Leakage Rate A
- EN 1866
- API 6D

MODEL SLHBFFS-T 150 TO 2500 CLASS TRIPLE OFFSET

MATERIALS

Body Carbon Steel / Stainless Steel / Ni-Al-Bronze / Hastelloy / Inconel / Titanium / Other

Disc Carbon Steel / Stainless Steel / Ni-Al-Bronze / Hastelloy / Inconel / Titanium / Other

Stem 410 SS, 17-4PH & XM-19 + Nitrided/ENP & Other Materials

Seat Duplex, 321 SS, 316 SS Hardened, 316 SS, Stellite 21 & Other Materials



API 607 7th Ed., ISO 10497-5
Firesafe Certified

ISO 15848-2
Fugitive Emission Certified

STANDARD MULTI-LAMINATED SEAT

The APV-Superseal triple offset butterfly valve design incorporates metallic composite cone bevelling. The cam effect ensures the valve seat can be released from the seal ring through the whole switching process with zero friction between valve seat and plate seal ring during the entire stroke process. This extends valve life, ensures no over-travel of the disc, allows for a lower torque and ensures bubble tight closure of the valve, resulting in zero-leakage performance.

The butterfly plate seal ring is designed as multi-layered seal ring. This seal compresses on a radial basis and move flexibly and elastically.

Graphite + metal combination as standard. Optionally, sealing materials such as PTFE + metal combinations can be supplied for different temperature and medium.

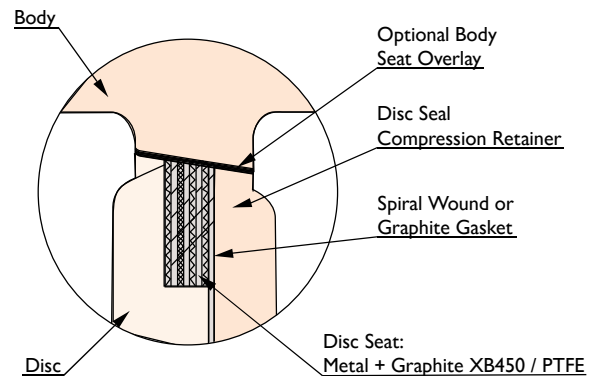

OPTIONAL SOLID METAL-TO-METAL SEAT

The APV-Superseal triple offset solid seat all metal to metal seat system are manufactured with three dimensional eccentric sealing structure. The valves are designed and manufactured with unique techniques and dedicated facilities for maximum machined accuracy. This ensures full cone match of sealing pair and eliminates the interference and abrasion between sealing faces.

A low degree of seating resistance, reliable sealing performance, reduced sealing face abrasion ensures a vastly extended valve life. The alloy hard sealing allows a higher pressure and temperature range whilst still providing bubble-tight shut off. Semi-flexible solid design is also available.

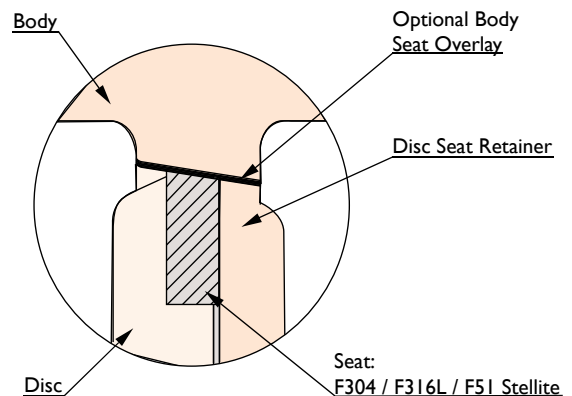

Bi-directional Tight Sealing Design

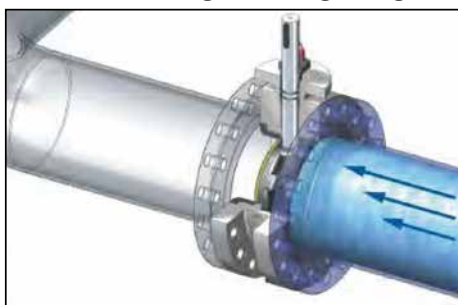

Preferred Direction

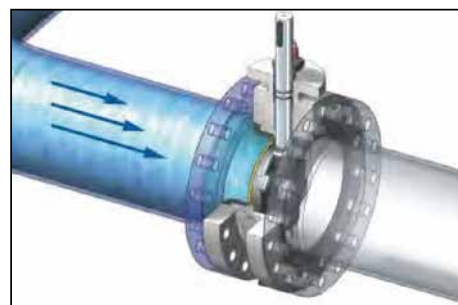

Non-Preferred Direction

MODEL SLHBFFS-T 150 TO 2500 CLASS TRIPLE OFFSET

MULTIPLE LAMINATED DISC SEATING

Key Components

1. Disc retainer
2. Seal ring triple laminated
3. Spiral wound or graphite gasket
4. Disc

Due to the elasticity and the radial compression of the multiple laminated seal ring, the contact pressure is uniformly distributed around the seating surface guaranteeing zero leakage.

The use of graphite (or PTFE) laminated between multiple metal sealing rings ensures tightness between seal ring layers and an ideal level of flexibility allowing each metal layer to independently find the optimal seating position. One-piece metal Solid Seal Ring (SSR) is also available.

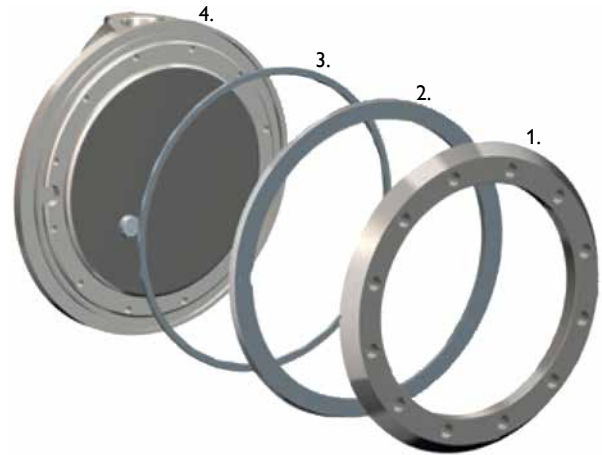

Slide Seal Design

This dynamic seating arrangement features a double inclined cone design. The disc seal ring slides into the seating area to close the valve. This slide touch provides a better sealing than the typical conventional of contact touch. Also, the seal ring is solid metal enabling it to sweep away particles left on seat surface to double secure a tight sealing and ensure a long life cycle.

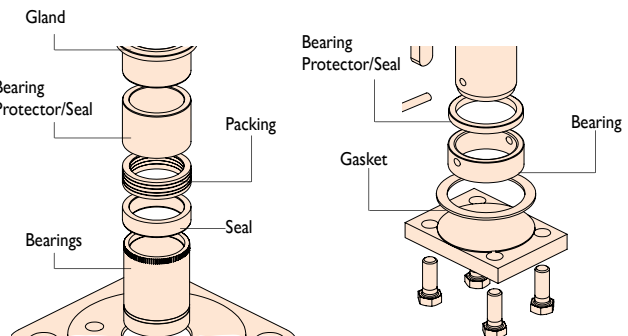

Top Bonnet Parts

Bottom Bonnet Parts

PRODUCT FEATURES

- Triple offset disc rotation to minimise the rubbing of the seat & seal contact surface and achieve high integrity sealing
- Bi-directional tight sealing - zero leakage
- Replaceable seat & seals
- Firesafe
- Low fugitive emissions - ISO 15848-1 approved

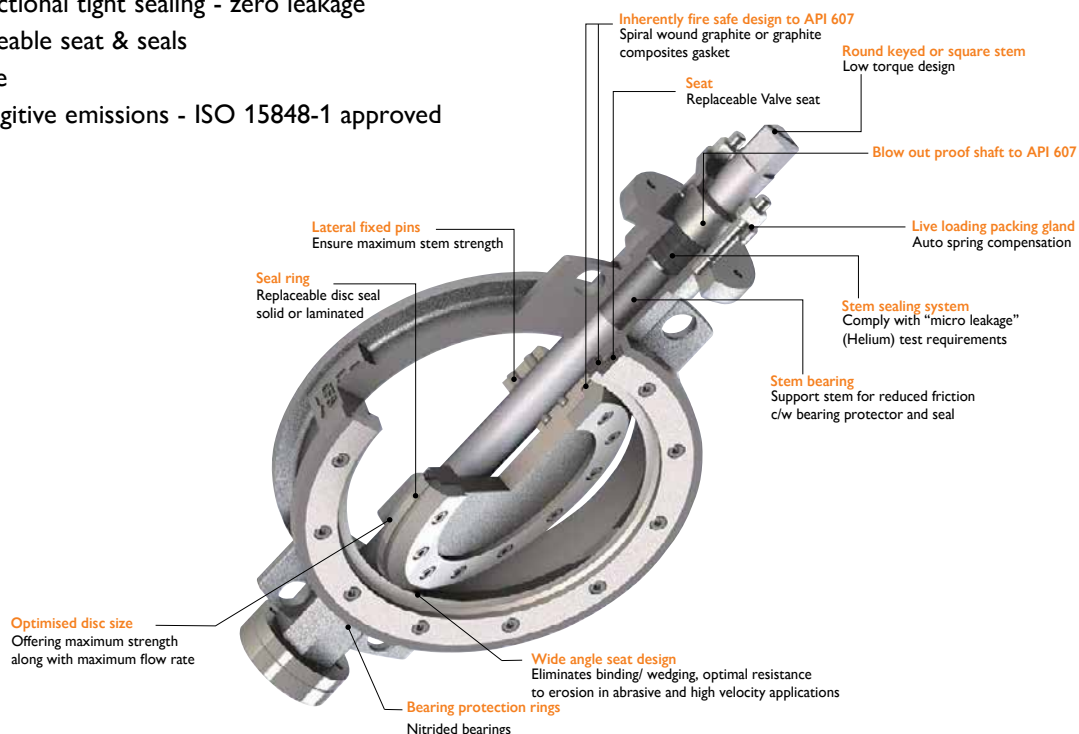

Indicative only. Refer to as built drawing design varies according to size & class.

MODEL SLHBFFS-T 150 TO 2500 CLASS TRIPLE OFFSET

DESIGN OPTIONS - TRIPLE OFFSET

One Piece Metal Seat Design Option

The semi-flexible metal one piece seal ring design guarantees the tightest shut-off and ensures safety in case of thermal expansion.

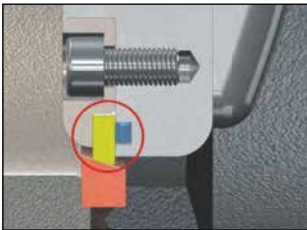
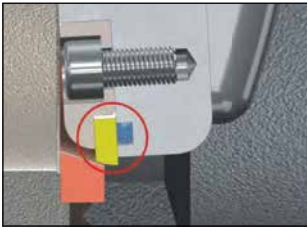

Stellite® Body Seat

The body seat can optionally be supplied in Stellite® #21 (zero leakage).

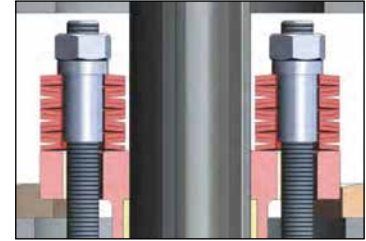
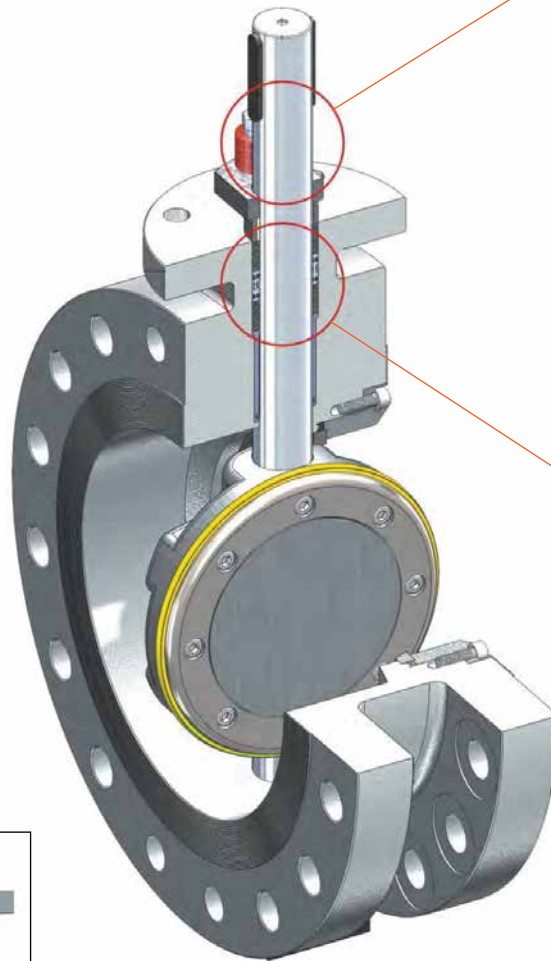

Live-loading Design Option

A Belleville spring provides abrasion compensation by compressing the packing constantly which ensures a long life cycle. Design varies depending on size & class.

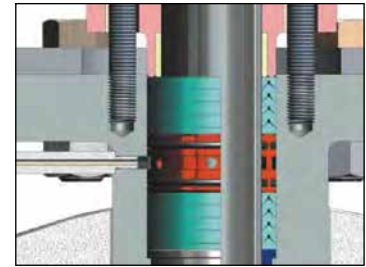

Low Emission Design

- Double packing design as standard guarantees safety.
- Leakage detection optional
- Emergency sealing injection optional.
- Additional 'chemical seal' packing gland seal system optional.

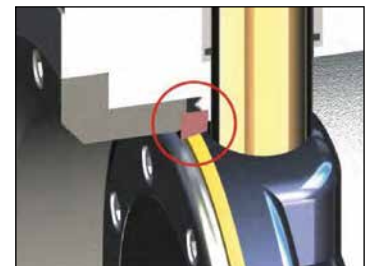

Replaceable Body Seat Design Option

The design includes a separate seat (not welded on the valve body) allowing ease of maintenance.

FIRESAFE, FUGITIVE EMISSION & CYCLE TEST CERTIFICATES

Fire Test Report
ANSI/API Standard 607, 6th Edition, 2010
ISO 10497: 2010

Performed for
Australian Pipeline Valve

www.australianpipelinevalve.com.au

2 inch Class 300
Double Eccentric
Product Code: SLHBF-1S

Project Number: 21300
Test Date: January 20, 2014

Performed by
YARMOUTH RESEARCH AND TECHNOLOGY, LLC

434 Walnut Hill Road
North Yarmouth, ME 04097 USA
(207) 829-5359
info@yarmouthresearch.com
www.yarmouthresearch.com

Fire Test Report
ANSI/API Standard 607, 6th Edition, 2010
ISO 10497: 2010

Performed for
Australian Pipeline Valve

www.australianpipelinevalve.com.au

6 inch Class 300
High Performance
Product Code: SLHBF-1S

Project Number: 21300
Test Date: January 20, 2014

Performed by
YARMOUTH RESEARCH AND TECHNOLOGY, LLC

434 Walnut Hill Road
North Yarmouth, ME 04097 USA
(207) 829-5359
info@yarmouthresearch.com
www.yarmouthresearch.com

ISO 15848-1:2015 Helium Fugitive Emission Test Report

Performed for
Australian Pipeline Valve

www.australianpipelinevalve.com.au

8 inch Class 150 RF
Double Eccentric Butterfly Valve
Product Code: SLHBF-1S

Project Number: 21300
Test Date: January 20, 2014

Performed by
YARMOUTH RESEARCH AND TECHNOLOGY, LLC

434 Walnut Hill Road
North Yarmouth, ME 04097 USA
(207) 829-5359
info@yarmouthresearch.com
www.yarmouthresearch.com

API Standard 622 Test Report
"Type Testing of Process Valve Packing for Fugitive Emission"
Second Edition, 2011

Performed for
Australian Pipeline Valve

<http://www.australianpipelinevalve.com.au>

3 inch Class 300 RF Butterfly Valve
C/W JA Series Torqturn Actuator
Product Code: Model SLHBF-FSALJBRG

Project Number: 21300
Test Start Date: January 20, 2014

Performed by
YARMOUTH RESEARCH AND TECHNOLOGY, LLC

434 Walnut Hill Road
North Yarmouth, ME 04097 USA
(207) 829-5359
info@yarmouthresearch.com
www.yarmouthresearch.com

VALVE AND ACTUATOR ENDURANCE CYCLE TEST CERTIFICATE

Name of Manufacturer: Australian Pipeline Valve Test Start Date: January 2014

DESIGNATION TESTED	SIZE	BODY	PRESSURE RATING	SEAT/SEALS	PRODUCT DESCRIPTION	STANDARD / METHOD	COVERAGE RANGE
ANSI MODEL F5500 BALL VALVE	2"	CAST IRON	150	PTFE/GRAPHITE/VTON	2" CLASS 150 RF BALL VALVE C/W RESERVE TORQTURN HEAVY DUTY QUARTER TURN PNEUMATIC ACTUATOR	API 607 AND ISO 10497-2010 EN 10619-100 OPERATIONAL CYCLES, ISO 10497-2010 OPERATIONAL CYCLES, ISO 10497-2010 OPERATIONAL CYCLES	100 TO 500 CLASS 150 TO 300
ANSI MODEL B7100 BALL VALVE	2"	CAST IRON	150	PTFE/GRAPHITE/VTON	2" CLASS 150 RF BALL VALVE C/W ANK SERIES TORQTURN HEAVY DUTY QUARTER TURN PNEUMATIC ACTUATOR	API 607 AND ISO 10497-2010 EN 10619-100 OPERATIONAL CYCLES, ISO 10497-2010 OPERATIONAL CYCLES, ISO 10497-2010 OPERATIONAL CYCLES	100 TO 500 CLASS 150 TO 300
ANSI MODEL P2000 GATE VALVE	2"	CAST IRON	150	METAL/GRAPHITE	2" CLASS 150 RF GATE VALVE C/W APV DAMPING GEAR VISE	API 607 AND ISO 10497-2010 EN 10619-100 OPERATIONAL CYCLES, ISO 10497-2010 OPERATIONAL CYCLES, ISO 10497-2010 OPERATIONAL CYCLES	100 TO 500 CLASS 150 TO 300
ANSI MODEL 300 RF BUTTERFLY VALVE C/W JA SERIES TORQTURN ACTUATOR	3"	CAST IRON	300	PTFE/GRAPHITE/VTON	3" CLASS 300 RF BUTTERFLY VALVE C/W JA SERIES TORQTURN HEAVY DUTY QUARTER TURN PNEUMATIC ACTUATOR	API 607 AND ISO 10497-2010 EN 10619-100 OPERATIONAL CYCLES, ISO 10497-2010 OPERATIONAL CYCLES, ISO 10497-2010 OPERATIONAL CYCLES	100 TO 500 CLASS 150 TO 300

Laboratory Information:
Name: Yarmouth Research and Technology, LLC
Address: 434 Walnut Hill Road, North Yarmouth, ME 04097 USA
Tester: Matthew Wasielewski, PE
www.yarmouthresearch.com
(207) 829-5359

Matthew Wasielewski

DNV DET NORSKE VERITAS INSPECTION REPORT

Ref: NY-14-0158-0
Date: 20 January 2014
Type: FALSA

This is to certify that at the request of the Australian Pipeline Valve Plain, Australia, the undersigned Surveyor to this Society did attend the Yarmouth Research and Technology Facility, North Yarmouth, ME, USA on 20 January, 2014, February and 20 March 2014 in order to witness Fire testing in accordance with ANSI/API Standard 607, 6th Edition, and ISO 10497-2010 requirements on the following (1) valve:

Product: 3 inch Class 300 RF Ball Valve C/W JA Series Torqturn Actuator
Manufacturer: Australian Pipeline Valve
Valve Product Code: SLHBF-1S
Actuator Drawing: JE10121V
Test Pressure: 600 psig at 1500 RPM
Test Frequency: 2550 Comp
Number of Mechanical Cycles: 1500 Reqs
Number of Thermal Cycles: 1500 Comp
Test Media: 8 Comp Meth
Cycling Rate: 60 seconds
Cycle Stroke: 1/2 turn
Valve Body: ASTM A21
Valve Shaft/Seat Retainer: SS 316
Locking Pin/Packing Studs: SS 316
Body Packing Description: PTFE+SS
Seat Ring: SS316
Guide Bush: SS316
Item: 2.6

Attached is the Yarmouth Research and Technology Valve and Actuator Endurance Cycle Test Certificate No. 1, dated 10/09/14 and duly endorsed by the witnessing Surveyor.

For Det Norske Veritas (USA), Inc.
Paul R. Salvemini
New York Station

David Bernick

DNV-GL INSPECTION REPORT

Ref: NY-14-0158-0
Date: 20 January 2014
Type: FALSA

This is to certify that at the request of the Australian Pipeline Valve Plain, Australia, the undersigned Surveyor to this Society did attend the Yarmouth Research and Technology Facility, North Yarmouth, ME, USA on 20 January, 2014, February and 20 March 2014 in order to witness Fire testing in accordance with ANSI/API Standard 607, 6th Edition, and ISO 10497-2010 requirements on the following (1) valve:

Product: 2" Class 300 Stainless Steel Australian Pipeline Valve
Manufacturer: Australian Pipeline Valve
Valve Product Marking: SLHBF-1S
Pressure Rating: ASME Class 300
Is Valve "Self-Sealing" Model: No
DNV Type: SLHBF-1S
Drawing Number: Double Seaming Butterfly F51 SR 200 L10 20/06/14
Body Material: ASTM A321 CP
Disc/Valve Shaft/Disc Pin Material: SS316
Gland Packing Material: Carbon Steel + PTFE
Gland Flange Material: SS 316
Retainer Bolt Material: SS 316
Mounting Bracket Material: SS 316

Qualified Sizes: 2", 2-1/2", 3" and 4", of the same design made from ferritic pressure retaining materials.

Qualified Ratings: Classes 300, 450 and 600 valves of the same design made from ferritic pressure retaining materials.

The test rates are shown in the Fire Test Data Sheet 215067-1.10 and are within the ANSI/API Standard 607, 6th Edition requirements.

The above mentioned valve has passed the fire test.

Attached is the Yarmouth Research and Technology Fire Test Information Sheet 215067-1.11, dated 02/09/15.

For Det Norske Veritas (USA), Inc.
Guoqing Fu
New York Station

David Bernick

DNV-GL INSPECTION REPORT

Ref: NY-14-0158-0
Date: 20 January 2014
Type: FALSA

This is to certify that at the request of the Australian Pipeline Valve Plain, Australia, the undersigned Surveyor to this Society did attend the Yarmouth Research and Technology Facility, North Yarmouth, ME, USA on 21 July, 2015 in order to witness Fire testing in accordance with ANSI/API Standard 607, 6th Edition, 2010 (Identical to ISO 10497: 2010) requirements on the following (1) valve:

Product: 6" Class 150 High Performance Butterfly Valve
Manufacturer: Australian Pipeline Valve
Valve Product Marking: SLHBF-1S-ALDRD
Pressure Rating: ASME Class 150
Is Valve "Self-Sealing" Model: Yes
DNV Type: SLHBF-1S-ALDRD
Drawing Number: Double Offset Fireproof Drawing Item 1.1.1 (26/06/14)
Body Material: ASTM A216 WCB
Disc/Valve Shaft/Disc Pin Material: SS316
Gland Packing Material: C-3 + PTFE Corded
Gland Flange Material: Graphite
Mounting Bracket Material: Carbon Steel
Retainer Bolt Material: SS316
Bottom Cover Material: ASTM A216 Gr WCB

Qualified Sizes: 6", 8", 10" and 12" of the same basic valve design made from ferritic pressure retaining materials.

Qualified Ratings: Classes 150 and 300 valves of the same basic valve design made from ferritic pressure retaining materials.

The test rates are shown in the Fire Test Data Sheet 215067-1.11 dated 07/21/15 duly endorsed by the witnessing Surveyor, and are within the ANSI/API Standard 607, 6th Edition, requirements.

The above mentioned valve has passed the fire test.

Attached is the Yarmouth Research and Technology Fire Test Information Sheet 215067-1.11, dated 07/21/15.

For Det Norske Veritas (USA), Inc.
Guoqing Fu
New York Station

David Bernick

API 607, ISO 10497-5
Firesafe Certified

API 622 & ISO 15848-1
Endurance Test Certified

API 622 2011 2nd Edition
Fugitive Emission Certified

FIGURE NUMBER SYSTEM

SLHBF, SLHBFFS & SLHBFFS-T DOUBLE & TRIPLE OFFSET

SLHBF - A L J B R 1 G - MS

MODEL	RATINGS	END CONNECTIONS	BODY MATERIALS	TRIM MATERIALS	SEATING	SHAFT	PACKING	SPECIAL
SLBHF	A = 150 CLASS B = 300 CLASS C = 600 CLASS	F = FLANGED-SHORT G = FLANGED-LONG L = LUG TYPE	A = WCB B = WC1 C = WC6	A = F304/CF8 B = F316/CF8M C = F316L/CF3M	B = BUNA/NBR C = CARBON FILLED PTFE	1 = 17-4PH 2 = 431SS 3 = 316SS	G = GRAPHITE P = PTFE Z = SPECIAL	B = BI-DIRECTIONAL TESTED C = ADDITIONAL ELASTOMER/PTFE GLAND SEAL D = DOUBLE PACKING F = FLUSHING PORT G = LIVE LOADED PACKING GLAND M = MONITORING PORT N = NACE O = OXYGEN CLEANED P = PEEK/ COMPOSITE BEARING R = CHLORINE SERVICE S = STELLITE OVERLAY SEAT Z = OTHER
SLHBFFS	D = 900 CLASS E = 1500 CLASS	W = WAFER TYPE	D = WC9 E = C-5	D = F304L/CF3 E = F321	D = METAL ISO 5208-D H = PPL UUHMW POLYETHYLENE	4 = S31803/F51 5 = XM19/ NITRONIC 50		
SLHBFFS-T	F = AS/BST-E G = AS/BST-F H = AS/BST-H Z = SPECIAL		F = C-12 G = LCB H = LC3 I = CF8 J = CF8M K = CF3 L = CF3M M = CF8C N = CN7M P = WCC Z = SPECIAL	F = ALLOY-20 G = MONEL H = HASTELLOY I = WCB+ENP J = F51/S31803 Z = OTHER	K = KELF L = LAMINATED METAL & GRAPHITE M = METAL API 598 N = METAL CLASS IV O = METAL CLASS V P = PTFE Q = METAL ISO 5208-A R = RPTFE S = METAL CLASS VI T = LAMINATED METAL & PTFE V = VITON U = PEEK Y = DOUBLE BLOCK & BLEED Z = OTHER	6 = MONEL K500 7 = ALLOY 20 8 = 416SS 9 = OTHER BLANK = SAME AS DISC		
SLHBFFS-TD								

EXAMPLE - SLHBF-ALJBR1G-MS

Double offset Standard
150LB
Lug type
CF8M Stainless steel body
F316 Trim
RPTFE Seat insert
17-4 PH Stem
Graphite Packing
Monitoring Port
Stellite Overlay Seat



API 622 & ISO 15848-1
Endurance Test Certified

SEAT DESIGNS

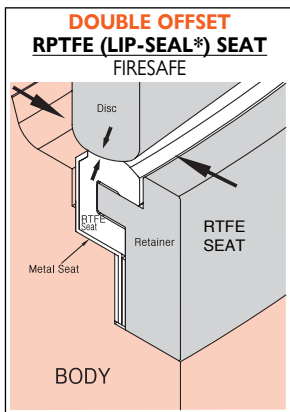

1. Double sealing construction
- Primary RTFE seat
- Secondary metal firesafe lip seat
2. Excellent sealing (in Bi-directions on request)
3. Conforms to API 607 6th & 7th Edition

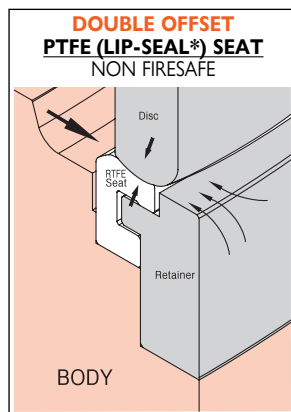

1. Reinforced PTFE
2. Excellent sealing (in both directions on request)
3. Cost effective

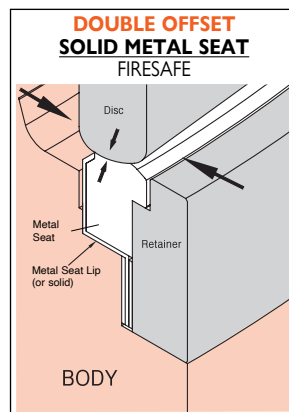

1. High temperature capability allows maximum of 620°C (1150°F)
2. High pressure capability
3. Stainless steel sealing area is resistant to corrosion and wear
4. Inherently firesafe in class V, VI or API 598 (metal seat) or ISO 5208-A/D shutoff

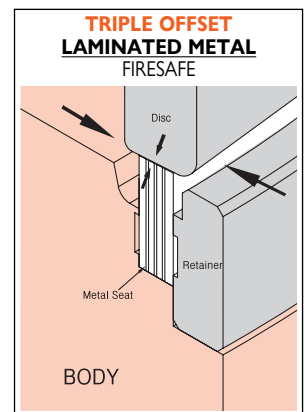

1. Multi-sealing triple eccentric construction
- Primary metal seat
- Multiple metal laminations graphite or PTFE filled
2. Excellent sealing in Bi-directions
3. Inherently firesafe to API 607 7th Edition
4. Stellite overlay all metal disc seat optional

*Or Flo-Seal style seat, refer page 5. Actual drawing supplied on request. Indicative drawings only.





LINED BUTTERFLY VALVE
10/16 BAR MODEL 2014 / 2016

TYPE: 2014, 2016, 2014A 1000 KPA & 1600 KPA RATED
SUIT AS/BS TABLE D, E, ASA 125, AS/BS/EN PN10, PN14 & PN16

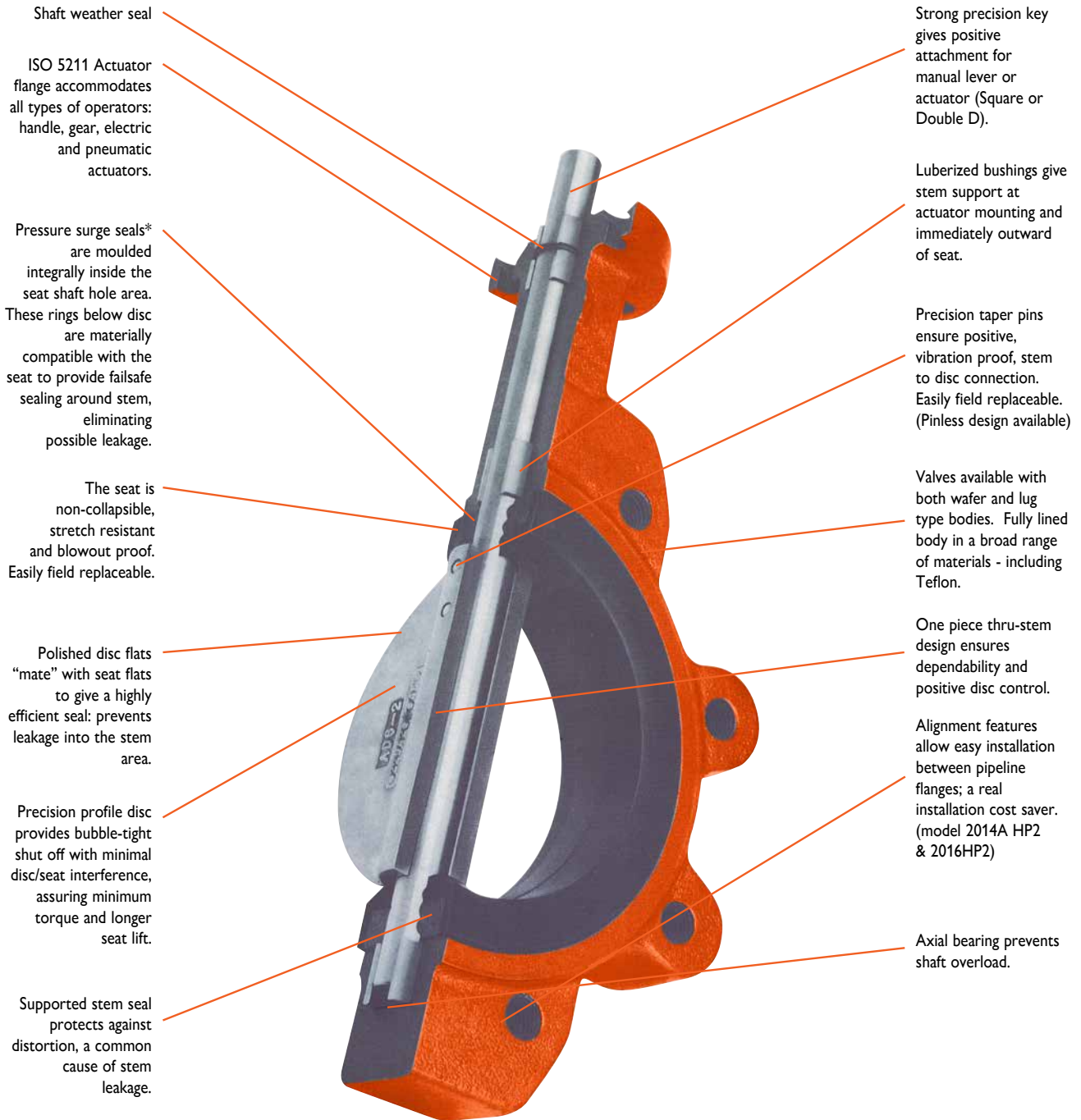

MODEL 2014 / 2016 - (PINNED STEM) SEAL CONSTRUCTION & FEATURES







<p>SUPERSEAL CONSTRUCTION</p>	 <p>The disc is precision manufactured to close tolerances on the O.D. and the flats. Seating edge is a polished half ball for torque control.</p>	<p>The modern seat and disc design insures positive sealing while maintaining low seating torque. The superseal design extends seat life by eliminating any bunching or tearing.</p>	 <p>The superseal seat design* has a much smaller mass of elastomer which can swell, in turn torque is controlled to a reasonable degree.</p>	<ul style="list-style-type: none"> • Precision machined disc edge & shaft flats. • Bonded distortion proof seat, close tolerances. • Positive shaft seals. • Low potential of seat swell. • Controlled torque by design superiority.
<p>TRADITIONAL CONSTRUCTION</p>	 <p>The conventional disc has been sanded to remove rough area, precise dimensions are not maintained.</p>	<p>The conventional design relies on distortion and bunching of the seat to achieve a bubble tight shutoff. Seat life is decreased causing higher maintenance cost and increased down time.</p>	 <p>Elastomers are subject to swelling from fluid absorption which can increase the mass of the seat. This increase can and often does cause excessively high seating torque. Seat life is shortened.</p>	<ul style="list-style-type: none"> • Non-precision disc dimensions. • Seat distorts during installation and operation. • Shorter seat life. • Higher torque due to bunching and potential swelling.

*Design varies according to size, rating and material specifications.

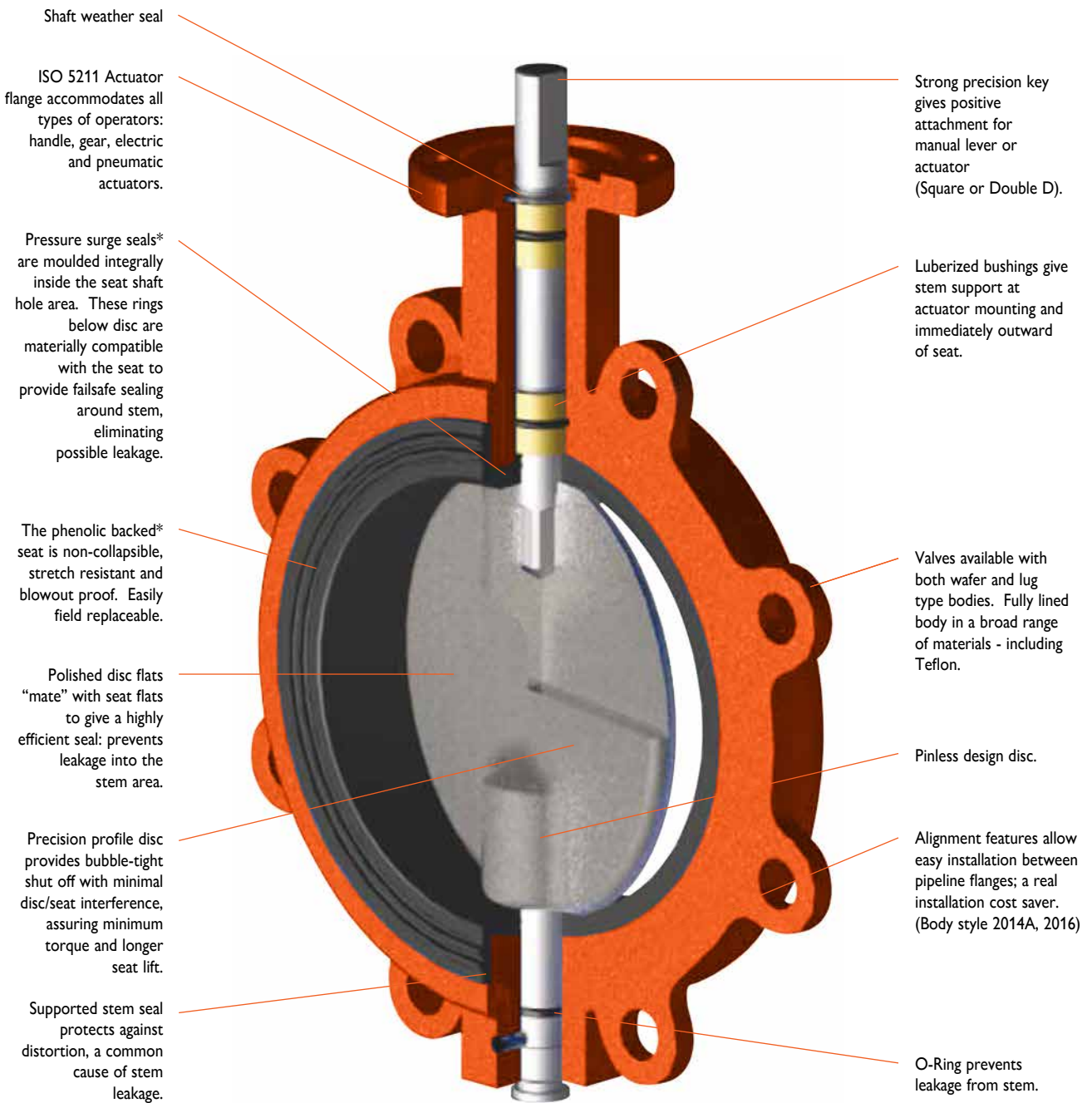
This brochure is general in it's nature and design is subject to change at any time without notice.

MODEL 2014 / 2016 - HU-1 (PINLESS) SEAL CONSTRUCTION & FEATURES



<p>SUPERSEAL CONSTRUCTION</p>	 <p>The disc is precision manufactured to close tolerances on the O.D. and the flats. Seating edge is a polished half ball for torque control. The disc is pinless design.</p>	<p>The modern seat and disc design insures positive sealing while maintaining low seating torque. The superseal design extends seat life by eliminating any bunching or tearing.</p>	 <p>The superseal seat design* has a much smaller mass of elastomer which can swell, in turn torque is controlled to a reasonable degree.</p>	<ul style="list-style-type: none"> • Pinless Disc • Precision machined disc edge and shaft flats. • Bonded distortion proof seat, close tolerances. • Positive shaft seals. • Low potential of seat swell. • Controlled torque by design superiority.
<p>TRADITIONAL CONSTRUCTION</p>	 <p>The conventional disc has been sanded to remove rough area, precise dimensions are not maintained.</p>	<p>The conventional design relies on distortion and bunching of the seat to achieve a bubble tight shutoff. Seat life is decreased causing higher maintenance cost and increased down time.</p>	 <p>Elastomers are subject to swelling from fluid absorption which can increase the mass of the seat. This increase can and often does cause excessively high seating torque. Seat life is shortened.</p>	<ul style="list-style-type: none"> • Non-precision disc dimensions. • Seat distorts during installation and operation. • Shorter seat life. • Higher torque due to bunching and potential swelling.

*Design varies according to size, rating and material specifications.

MODEL 2014 / 2016

SPECIFICATIONS

Available To Suit Following Flanging

ANSI (ASA) ASME B16.5 / B16.47, 125LB /150LB, AS 2129 Table D, E, AS 4087, PN14 & PN16. ISO 5752 / EN 1092.2 PN10, PN16, AS 4331.1 / ISO 7005-1 PN10, PN16, JIS etc. Face to face dimension available in accordance with BSEN 593 / BSEN 558 / API 609-A / ISO 5752 / AS 4795.

Fluid Application - Water, seawater, sewage, air, oil, powder, petroleum, gas, chemicals, salts, alkalines etc.

Design - Available in API 609 category A, ASME B16.34, AS 4795.1, EN 593, EN 558-1, MSS SP67.

Operation - Generally flow control lever & notch plate to 300NB. Gear operator 250NB & over.

Mounting - To ISO 5211 on request. Long lasting, high performance design.



Pneumatic Actuated Version

Pressure Rating

Bi-directional bubble-tight shut off seat tested to 110% of full rating.

2 types available in this model:-
Working pressure:150 psig (1000kPa) & 232 psig (1600kPa). See HP Version brochure if higher pressure required.

Over 600NB request pressure rating.

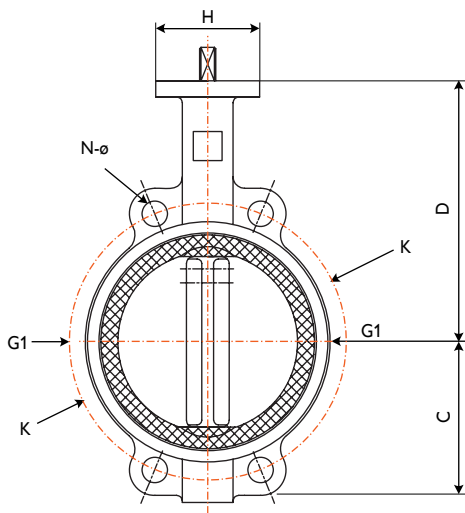

Wafer Style 2014A

(Semi-lugged with 2 or 4 lugs). PCD of Lug holes (K) supplied according to order i.e. ASA 125, AS/BS D, E etc.

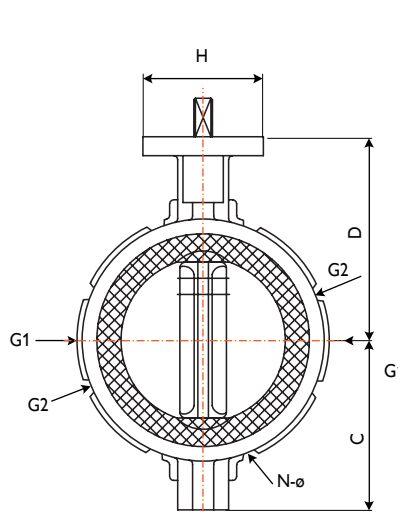

Wafer Style 2014

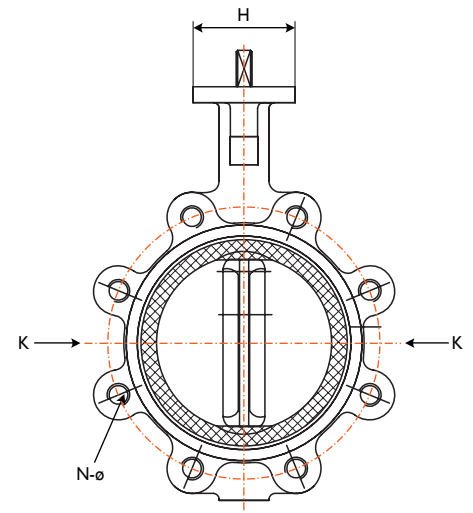

Lugged Style 2016

(Can be supplied ASA 125 AS/BS D, E etc.)

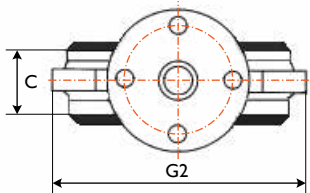

Semi Lug

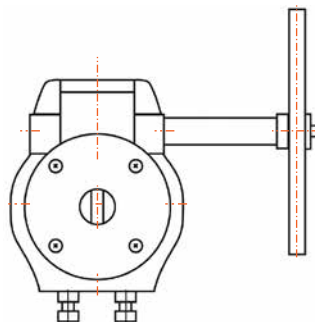

Gear Operated

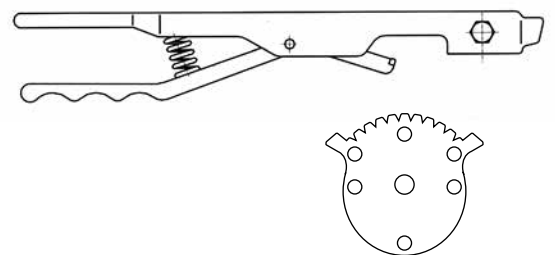

Lever & Notch Plate

General Applications	Continuous Working Temperature Range	Disc Material	Seat Material
Steam, Water, Hot Gases, Powders, Slurries & Aqueous Slurries of an abrasive nature	Liquids - 10°C to 120°C Dry Services - 10°C to 100°C	Stainless Steel	General Purpose EPDM
Brines, Sea Water, Estuary Water, Marine Bilge & Ballast Systems	-10°C to 90/100°C	Aluminium Bronze or ENP or S/S or Nylon coated	Black Nitrile or EPDM
Oils, Fuels, Water, Air, Gases, Powders, Pellets, Slurries etc.	Hydrocarbons (Except Aromatics) - 10°C to 90°C Other Liquids - 10°C to 90°C Dry Services - 10°C to 60°C	Teflon or Nylon Coated or SG Iron or ENP or stainless	Black Nitrile
Water & other non erosive fluids	All -10°C to 90/100°C (Solid PTFE will do up to 160°C)	S.G Iron or powder coated	ANY

MODEL 2014 / 2016

MATERIALS

1. Body	Cast iron, stainless ductile iron, aluminium, carbon steel, stainless steel etc
2. Disc	316SS, 304SS, AL-Bronze, hard epoxy coated, hard rubber coated, nickel plated, PTFE coated, 410SS etc
3. Stem	316SS, 304SS, PTFE coated, AL-Bronze etc.
4. Seat	NBR (90°-100°C), EPDM (110°C) teflon, food grade rubber, Buna-N, Viton, Hypalon etc
5. Retaining Pin/ Gland Ring	304SS/316SS/410SS
6. Bottom Bushing	Bronze/Nylon
7. O-Rings	NBR (nitrile)/EPDM
8. Upper Bush	Delrin/Nylon/Bronze

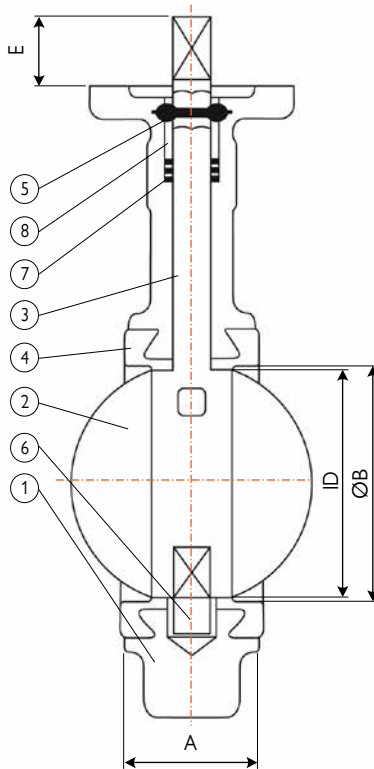

DIMENSIONS (MM)

Valve Size	Dimension							Weight Kg	Suit Flanging					
	in	mm	A	B	C	D	E		H	ID	G1*	G2*	K*	N-ø
1	25	31		57	85					1.1	-	-	-	-
1-1/4	32	32		60	100					1.8	-	-	-	-
1-1/2	40	33		58	124		90	40		2	-	-	-	-
2	50	43		57	55	143	30	90	52	2.3	-	-	-	-
2-1/2	65	46		70	64	155	30	90	65	2.7	-	-	-	-
3	80	46		82	72	162	30	90	80	3.6	-	-	-	-
4	100	52		104	90	181	30	90	100	5	-	-	-	-
5	125	56		127	101	197	30	90	125	6.1	-	-	-	-
6	150	56		150	114	210	30	90	148	7.1	-	-	-	-
8	200	60		194	145	240	35	95	197	13.6	-	-	-	-
10	250	68		247	178	286	35	110	247	21.3	-	-	-	-
12	300	78		297	204	309	35	120	297	32.2	-	-	-	-
14	350	78		330	266	355	55	125	327	85	-	-	-	-
15	375	86		387	300	380	55	175	387		-	-	-	-
16	400	86/102		387	300	380	55	175	387	106	-	-	-	-
18	450	105/114		435	323	425	55	175	435	135	-	-	-	-
20	500	130/127		489	350	430	90	210	477	170	-	-	-	-
24	600	150/154		602	407	500	90	210	560	250	-	-	-	-

650NB to 900NB refer to separate drawing
 *G1, G2, K & N-Ø available to suit: AS/BST-C, D, E, ASA 125, PN10, PN16, JIS etc.
 Sizes shown are subject to variation at any time

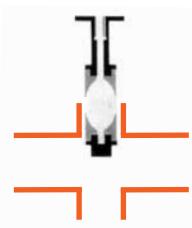

INSTALLATION (DO NOT USE GASKETS)

Pipework opened to allow valve free entry, disc in semi-closed position

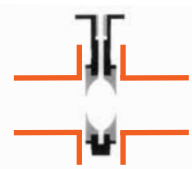

Valve in semi-open to protect disc edge and reduce rubber interference during installation and start up, this helps reduce initial torque build up.

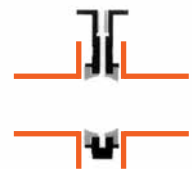

Disc should be turned to full open position after flange alignment and before doing up flange bolts.

TORQUE

Torques based on clean, wet fluids. 20% safety factor recommended. For oil/lubricated fluids torque can reduce from 20% to 50%.

For non lubricating dry gases torque can increase 35% to 80%. (see separate chart).

Dry or abrasive/dirty service, temperature variations as well as infrequent use can all dramatically increase torque.

SEAT PRESSURE / TEMPERATURE

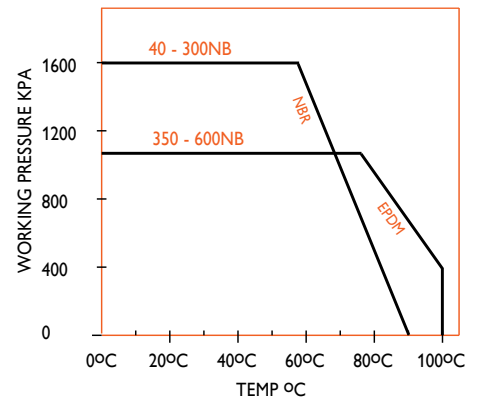

OPERATING TORQUE (NM)

2014/2014A/2016

Valve Size	Δ kPa (psi)					
	in	mm	170 (25)	340 (50)	680 (100)	1020 (150) 1600 (232)
2	50		12	12	20	25 35
2-1/2	65		12	12	25	30 42
3	80		18	19	30	35 60
4	100		32	33	40	50 80
5	125		49	51	60	70 90
6	150		72	76	70	90 215
8	205		127	139	160	190 400
10	255		196	219	240	300 -
12	305		289	323	400	500 -
14	355		439	481	554	830 -
16	405		568	636	762	1110 -
18	455		751	831	1005	1390 -
20	510		931	1052	1282	1730 -
24	610		1375	1559	1871	2020 -

* Torque shown is break/resetting (same).

This brochure is general in it's nature and details shown are subject to change at any time without notice.





LINED BUTTERFLY VALVE
16/21 BAR MODEL 2014-HP / 2016-HP

TYPE: 2014-HP, 2016-HP, 2014A-HP 2100 KPA RATED TO 300NB 1600 KPA RATED TO 350-500NB
SUIT AS/BS TABLE F ANSI 150 AS/EN/BS PN16/20/21

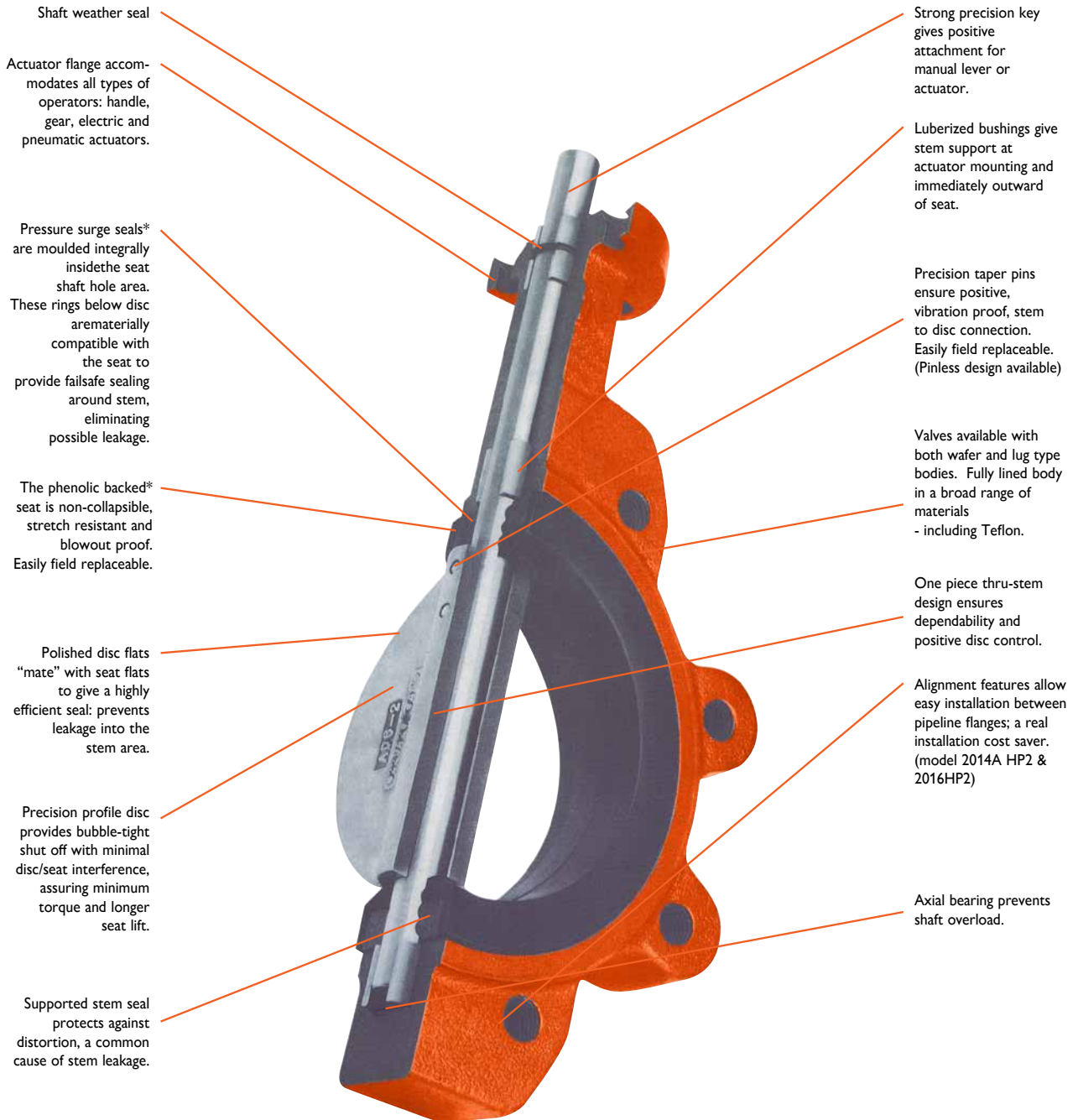

MODEL 2014-HP / 2016-HP SEAL CONSTRUCTION & FEATURES







<p style="writing-mode: vertical-rl; transform: rotate(180deg);">SUPERSEAL CONSTRUCTION</p>	 <p>The disc is precision manufactured to close tolerances on the O.D. and the flats. Seating edge is a polished half ball for torque control.</p>	<p>The modern seat and disc design insures positive sealing while maintaining low seating torque. The superseal design extends seat life by eliminating any bunching or tearing.</p>	 <p>The superseal seat design* has a much smaller mass of elastomer which can swell, in turn torque is controlled to a reasonable degree.</p>	<ul style="list-style-type: none"> • Precision machined disc edge & shaft flats. • Bonded distortion proof seat, close tolerances. • Positive shaft seals. • Low potential of seat swell. • Controlled torque by design superiority.
<p style="writing-mode: vertical-rl; transform: rotate(180deg);">TRADITIONAL CONSTRUCTION</p>	 <p>The conventional disc has been sanded to remove rough area, precise dimensions are not maintained.</p>	<p>The conventional design relies on distortion and bunching of the seat to achieve a bubble tight shutoff. Seat life is decreased causing higher maintenance cost and increased down time.</p>	 <p>Elastomers are subject to swelling from fluid absorption which can increase the mass of the seat. This increase can and often does cause excessively high seating torque. Seat life is shortened.</p>	<ul style="list-style-type: none"> • Non-precision disc dimensions. • Seat distorts during installation and operation. • Shorter seat life. • Higher torque due to bunching and potential swelling.

*Design varies according to size, rating and material specifications.

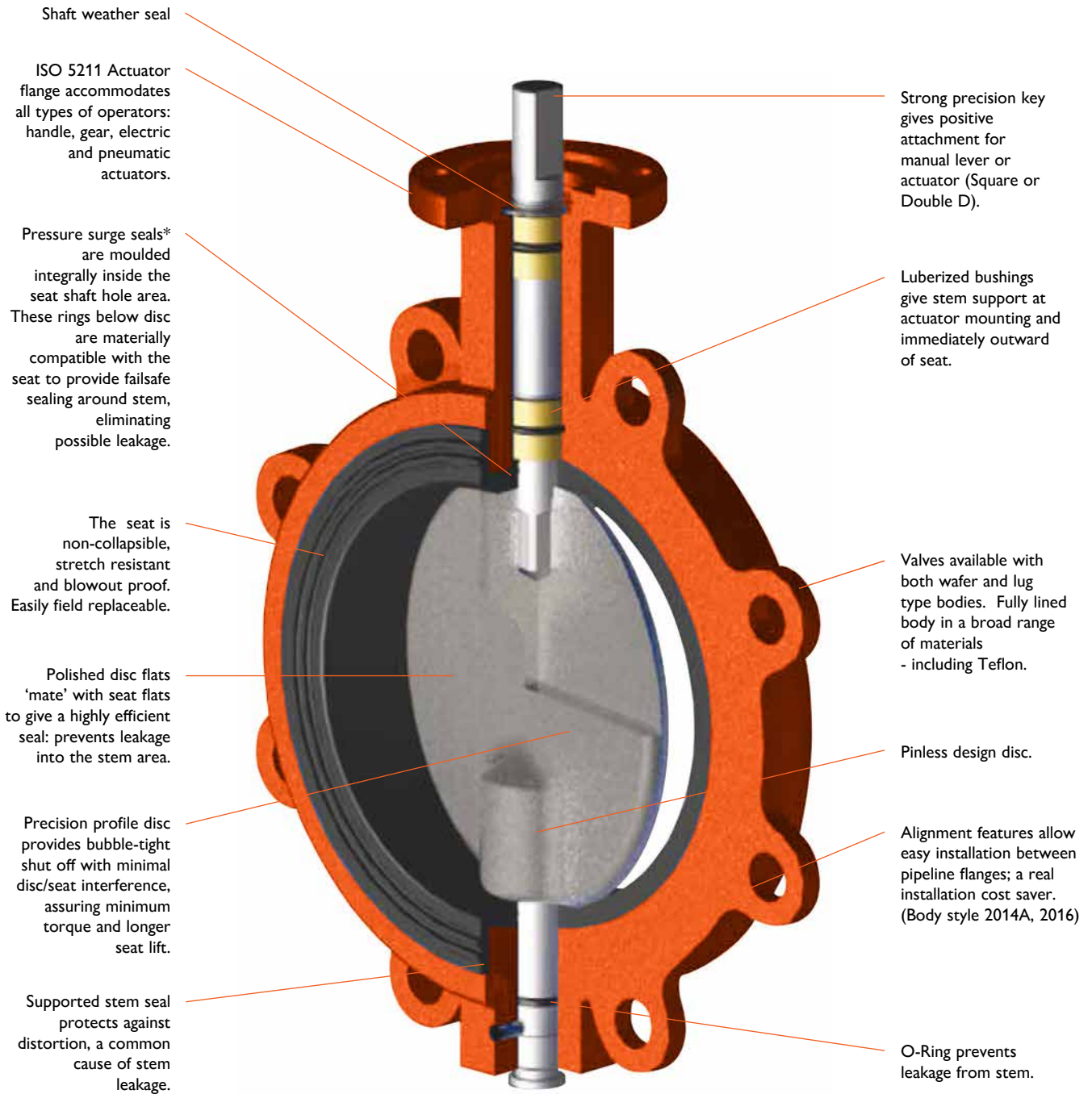
MODEL 2014-HP - HU-1 / 2016-HP

SEAL CONSTRUCTION & FEATURES - PINLESS DESIGN



<p>SUPERSEAL CONSTRUCTION</p>	 <p>The disc is precision manufactured to close tolerances on the O.D. and the flats. Seating edge is a polished half ball for torque control. The disc is pinless design.</p>	<p>The modern seat and disc design insures positive sealing while maintaining low seating torque. The superseal design extends seat life by eliminating any bunching or tearing.</p>	 <p>The superseal seat design* has a much smaller mass of elastomer which can swell, in turn torque is controlled to a reasonable degree. The 21 bar rated valve has a bonded hard lined backing.</p>	<ul style="list-style-type: none"> • Pinless Disc • Precision machined disc edge and shaft flats. • Bonded distortion proof seat, close tolerances. • Positive shaft seals. • Low potential of seat swell. • Controlled torque by design superiority.
<p>TRADITIONAL CONSTRUCTION</p>	 <p>The conventional disc has been sanded to remove rough area, precise dimensions are not maintained.</p>	<p>The conventional design relies on distortion and bunching of the seat to achieve a bubble tight shutoff. Seat life is decreased causing higher maintenance cost and increased down time.</p>	 <p>Elastomers are subject to swelling from fluid absorption which can increase the mass of the seat. This increase can and often does cause excessively high seating torque. Seat life is shortened.</p>	<ul style="list-style-type: none"> • Non-precision disc dimensions. • Seat distorts during installation and operation. • Shorter seat life. • Higher torque due to bunching and potential swelling.

MODEL 2014-HP / 2016-HP

SPECIFICATIONS

Available To Suit Following Flanging

ANSI (ASA) ASME B16.5 / B16.47 150LB, AS 2129 Table E & F, AS 4087, PN14, PN16 & PN21. EN 1092-2 PN10, PN16, PN25, JIS, DIN etc. Face to face dimension available in accordance with BSEN 593 / BSEN 558 / API 609-A / ISO 5752 / AS 4795.

Design - Available in API 609-A, AS 4795.1, BSEN 593, BSEN 558-1.

Fluid Application - Water, seawater, sewage, air, oil, powder, petroleum, gas, chemicals, salts, alkalines etc.

Operation - Generally flow control lever & notch plate to 300NB, gear op over 300NB.

Mounting - To ISO 5211 on request. Long lasting, high performance design.

Pressure Rating (to 300NB)

2100 kPa Working pressure:-
Bi-directional bubble-tight shut off and seat tested to 110% of full rating.

Test Pressure: 314 psi.

Over 300NB rating is 1600 kPa to 400NB

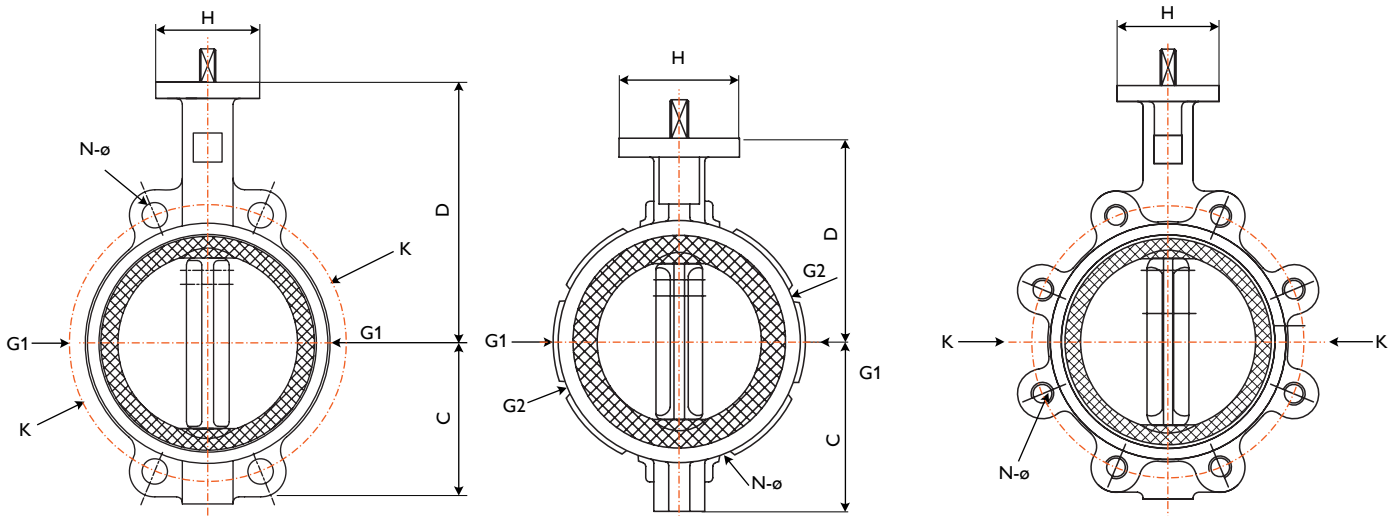

Wafer Style 2014A HP

Semi-lugged with 2 or 4 lugs). PCD of Lug holes supplied according to order i.e. ASA 150, AS/BS E, F etc

Wafer Style 2014 HP

Lugged Style 2016 HP

(Can be supplied ANSI 150 AS/BS E, F etc.)

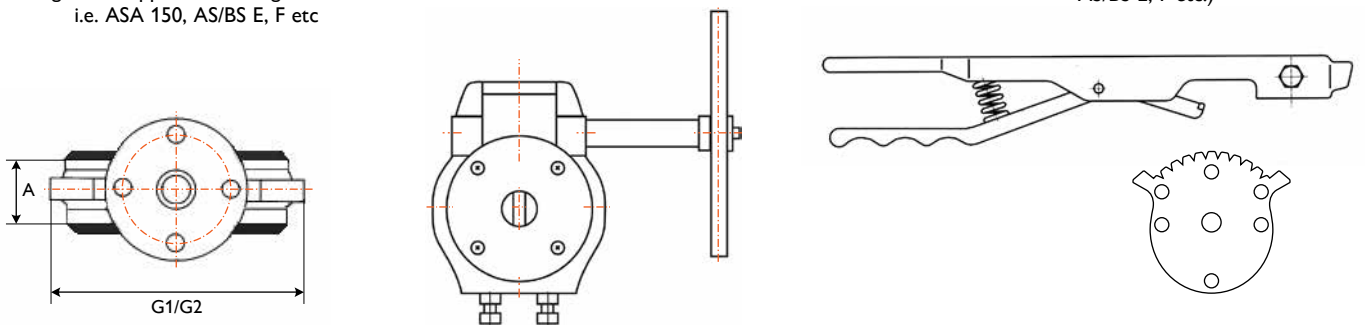

Semi Lug

Gear Operated

Lever & Notch Plate

General Applications	Continuous Working Temperature Range	Disc Material	Seat Material
Steam, Water, Hot Gases, Powders, Slurries & Aqueous Slurries of an abrasive nature	Liquids - 10°C to 120°C Dry Services - 10°C to 100°C	Stainless Steel	General Purpose EPDM
Brines, Sea Water, Estuary Water, Marine Bilge & Ballast Systems	-10°C to 90/100°C	Aluminium Bronze or ENP or S/S or Nylon coated	Black Nitrile or EPDM
Oils, Fuels, Water, Air, Gases, Powders, Pellets, Slurries etc.	Hydrocarbons (Except Aromatics) - 10°C to 90°C Other Liquids - 10°C to 90°C Dry Services - 10°C to 60°C	Teflon or Nylon Coated or SG Iron or ENP or stainless	Black Nitrile
Water & other non erosive fluids	All -10°C to 90/100°C (Solid PTFE will do up to 160°C)	S.G Iron or powder coated	ANY

MODEL 2014-HP / 2016-HP

MATERIALS

1. Body	Cast iron, stainless ductile iron (ASTM A396), aluminium, carbon steel etc
2. Disc	316SS, 304SS, AL-Bronze, hard epoxy coated, hard rubber coated, nickel plated, PTFE coated, 410SS etc
3. Stem	316SS, 304SS, 410SS, PTFE coated etc
4. Seat	NBR (90°C), EPDM (100°C), solid teflon (170°C), phenolic backed teflon (160°C), EPDM back teflon (150°C), food grade rubber, Buna-N, Viton, Hypalon etc
5. Retaining Pin/Gland Ring	304SS/410SS/316SS
6. Bottom Bushing	Bronze/Nylon
7. O-Rings	NBR (nitrile)/EPDM
8. Upper Bush	Delrin/Nylon/Bronze
9. Backing	Phenolic (where applicable)

DIMENSIONS (MM)

Valve Size		Dimension							Weight Kg	Suit Flanging			
in	mm	A	B	C	D	E	H	ID		G1*	G2*	K*	N-ø
1	25	31		57	85					1.1			
1-1/4	32	32		60	100					1.8			
1-1/2	40	33		58	124		90	40		2			
2	50	43	57	55	143	30	90	52		2.3			
2-1/2	65	46	70	64	155	30	90	65		2.7			
3	80	46	82	72	162	30	90	80		3.6			
4	100	52	104	90	181	30	90	100		5			
5	125	56	127	101	197	30	90	125		6.1			
6	150	56	150	114	210	30	90	148		7.1			
8	200	60	194	145	240	35	95	194		13.6			
10	250	68	247	178	286	35	110	247		21.3			
12	300	78	298	204	309	35	120	297		32.2			
14	350	76	330	266	355	55	125	327		85			
15	375	86	387	300	380	55	175	385					
16	400	86/102	390	300	380	55	175	387		106			

*G1, G2 & K & N-ø available to fit any flanging i.e. AS/BS E, F, ASA 125, PN16, JIS etc.
 Sizes shown are subject to variation at any time.

OPERATING TORQUE (NM)

Valve Size		Δ kPa (psi)		
in	mm	1700(200)	2040(250)	2468(300)
2	50	30	37	45
2-1/2	65	35	43	55
3	80	55	67	75
4	100	70	90	105
5	125	100	150	180
6	150	170	225	240
8	200	300	416	490

• Torque (NM) shown is break/reseating (same)

SEAT PRESSURE / TEMPERATURE

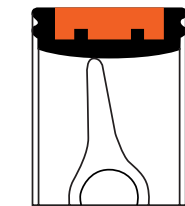
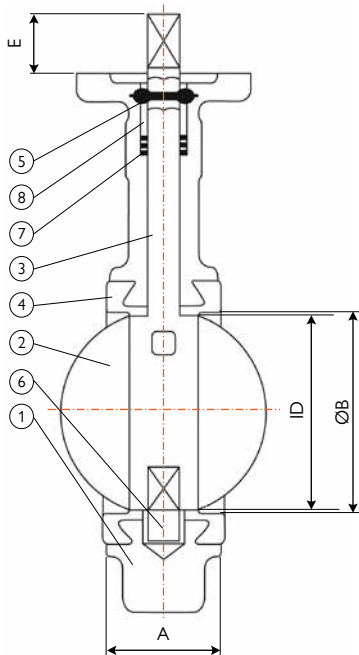
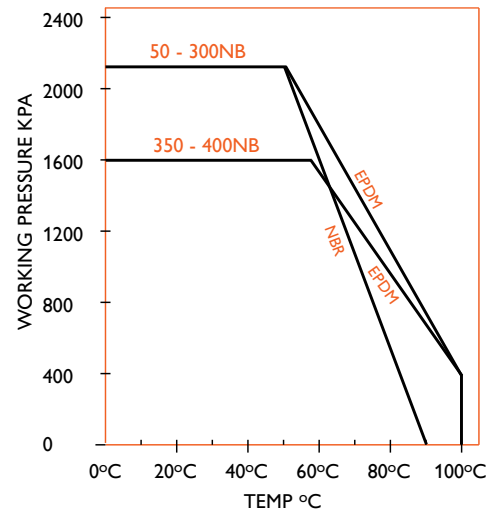

Vulcanised liner design (21 bar)

The vulcanised tongue and grooved seat design with spherical sealing provides rigidity to prevent distortion at higher pressure and ensures compression between the precision profile disc and seat. The rolling action of the disc coupled with the stability of the seat eliminates any tearing or bunching thus minimising seat damage.

Vulcanising the elastomer liner combined with a tongue and grooved body ensures complete support and increased stability to the seat to withstand higher pressures. This guarantees positive control against distortion, particularly in the stem seal area, eliminating risks of leakage.

The seat design only has a small volume of elastomer swelling hence the torque is reduced and longer life is assured.



TORQUE

Torques based on clean, wet fluids. 20% safety factor recommended. For oil/lubricated fluids torque can reduce from 20% to 50%. For non lubricating dry gases torque will increase 35% to 80%. Also, dry or abrasive/dirty service, temperature variations as well as infrequent use can all dramatically increase torque.

This brochure is general in it's nature and details shown are subject to change at any time without notice.

PTFE / FEP / PFA / ETFE & ELASTOMER LINED BUTTERFLY VALVE 2 PIECE BODY MODEL 2014-2P



Service

Hygienic, Chemical, Industrial, Mining, Oil & Gas, High Temperature

Design

Centric, Wafer & Lugged API 609, MSS SP 67 BS/EN 593, BS/EN 558-1

Size Range

50 to 600mm

Pressure Rating

PN 3.5, PN10, PN16

500 kPa max rating on dead end service

1600 kPa rating available up to 600NB

Temperature Rating

Minus 20°C to 110°C EPDM liner & seals

Minus 8°C to 90°C Buna N liner & seals

Minus 5°C to 110°C Teflon liner, NBR backed

Minus 20°C to 130°C Teflon liner, EPDM backed

Minus 10°C to 100°C Urethane liner

Minus 20°C to 150°C solid Teflon liner & seals

Standard Materials

Body Cast Iron, 316SS etc

Disc 316 S/S EPDM encapsulated, Teflon (PFA) encapsulated

Stem 316 S/S, EPDM or Teflon (PFA) encapsulated

Seat EPDM or Buna N

Teflon - Buna N backed

Teflon - EPDM backed

Urethane

Teflon - solid

Flanging

AS 2129 Table D, E

AS 4087 PN14, PN16, ANSI Class 125/150

EN 1092-2, PN10, PN16

Retaining System

The shaft is retained in the body with retaining ring, a thrust washer and two C-Rings, providing a 'blow-out proof' shaft assembly. The retaining ring may be easily removed with a standard hand tool on field disassembly.

Shaft

One-piece through shaft ensures dependability and positive disc positioning.

Bushings

Shaft bushings reduce torque and isolate the shaft from the valve body, preventing seizure of the shaft due to corrosion in the shaft journal.

PTFE Seat

Solid PTFE or EPDM with phenolic-backed seat provides resilient support for the molded PTFE, thus maximising the shut-off and cycle life of the seat.

Disc and Shaft Connection

The square connection eliminates shaft retention components being exposed to the line media. Maximum flow is achieved.

Mounting Flange

ISO 5211 mounting flange accommodates direct mounting of all types of actuators, including: handles, gear operators, electric and pneumatic.

O-Ring

Shaft seal provides further assurance against stem leakage.

Flats Seal

Smooth finished disc flats mate with seat flats to give a highly efficient primary seal that prevents leakage into the shaft area.

Two Piece Body

Two piece body allows for ease of assembly and maintenance.

Disc

Stainless steel or stainless steel PFA (min. thickness 0.1mm) coated disc prevents chemical corrosion from flow media. Precision profile provides bubble-tight shut-off, assures minimum torque and longer seat life.

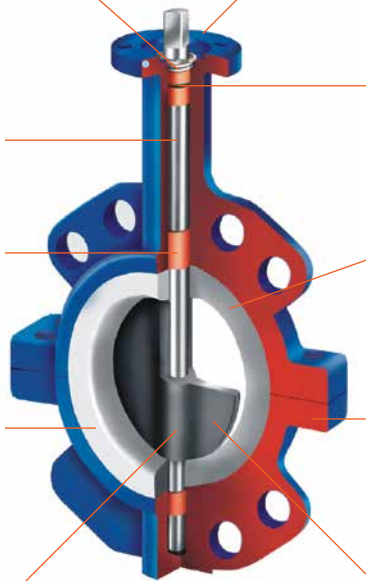

Atmospheric seal

(O-Ring)

Providing external corrosion protection

Triple stem bearing

Maintenance free, with SS + PTFE / Polyacetal bearings

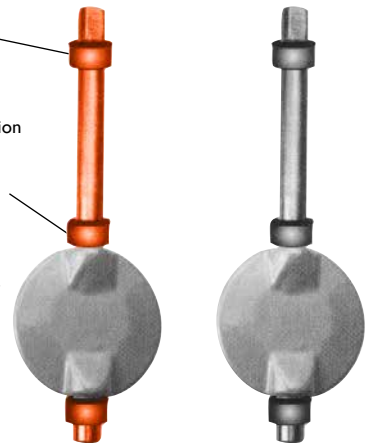

Separate Disc and Stem

One Piece Fully Coated Disc and Stem

MODEL 2014-2P

MATERIALS

Component	Material Options Available
Body (1)	Cast Iron FS220 Ductile Iron GGG40 Carbon Steel ASTM A216 WCB Stainless Steel ASTM A351 CF8 Stainless Steel ASTM A351 CF8M
Disc (2) & Stem (3)	Carbon Steel ASTM A105/WCB + Nylon Coating or PTFE Coated Stainless Steel ASM A351 CF8/CF8M/316L/CF3M Aluminium Bronze Nickel Titanium Hastalloy
Liner (4)	PTFE (Solid) FEP (Solid) PFA (Solid) ETFE (Solid) Buna N (Nitrile) EPDM Silicon Viton PTFE (EPDM Backed) White food grade Buna N White food grade EPDM



WAFER

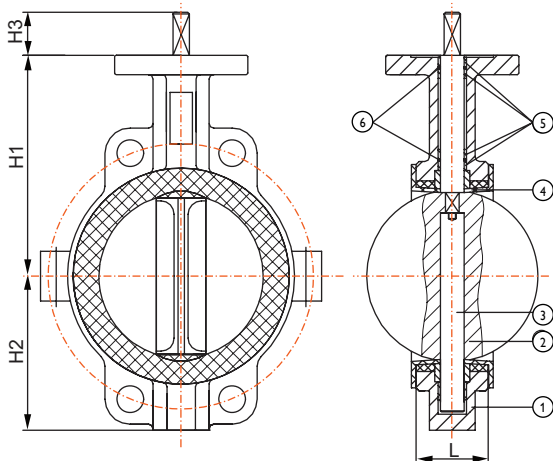

LUG

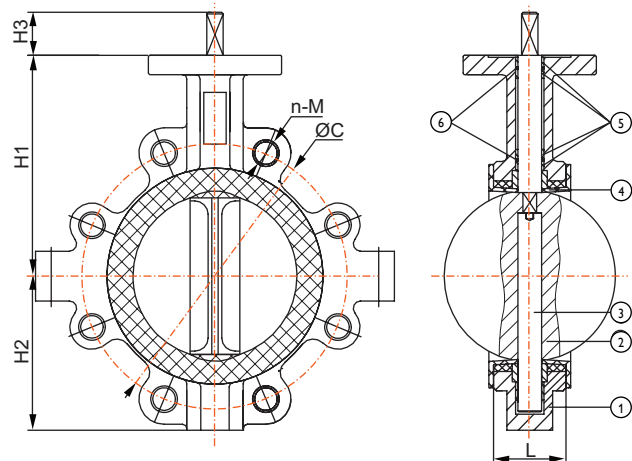

DIMENSIONS (MM)

SIZE		L	H1	H2	H3	ISO 5211				EN 1098 PN16			ØZ	ØF	H
DN	NPS					No.	ØN	Øc1	n1-Ød1	ØC	n-Ød	n-M			
40	1.5"	33	128	73	29	F05	65	50	4-Ø8	110	4-Ø18	4-M16	12.6	12.1	9
50	2"	43	135	73	29	F05	65	50	4-Ø8	125	4-Ø18	4-M16	12.6	12.1	9
65	2-1/2"	46	135	80	29	F05	65	50	4-Ø8	145	4-Ø18	4-M16	12.6	12.1	9
80	3"	46	138	90	29	F05	65	50	4-Ø8	160	8-Ø18	8-M16	12.6	12.1	9
100	4"	52	158	116	29	F07	90	70	4-Ø10	180	8-Ø18	8-M16	15.77	14.1	11
125	5"	56	175	130	29	F07	90	70	4-Ø10	210	8-Ø18	8-M16	18.92	18.1	14
150	6"	56	188	148	29	F07	90	70	4-Ø10	240	8-Ø22	8-M20	18.92	18.1	14
200	8"	60	230	180	35	F10	125	102	4-Ø12	295	12-Ø22	12-M20	22.1	22.1	17
250	10"	68	270	220	35	F10	125	102	4-Ø12	355	12-Ø26	12-M24	28.45	28.1	22
300	12"	78	300	255	35	F10	125	102	4-Ø12	410	12-Ø26	12-M24	31.6	28.1	22

350NB to 400NB refer to drawing.

PARTS LIST

Parts	Description
1	Body
2	Disc
3	Stem
4	Seat
5	Bushing
6	O Ring

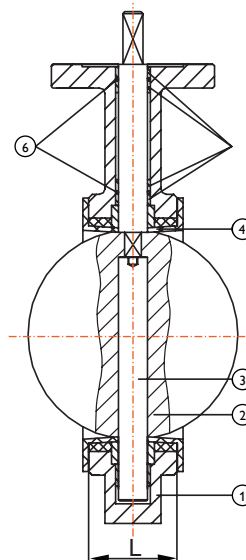

LARGE DIAMETER FLANGED BUTTERFLY VALVE RESILIENT SEAT DOUBLE / TRIPLE OFFSET MODEL HU-B60~63 PN10~25

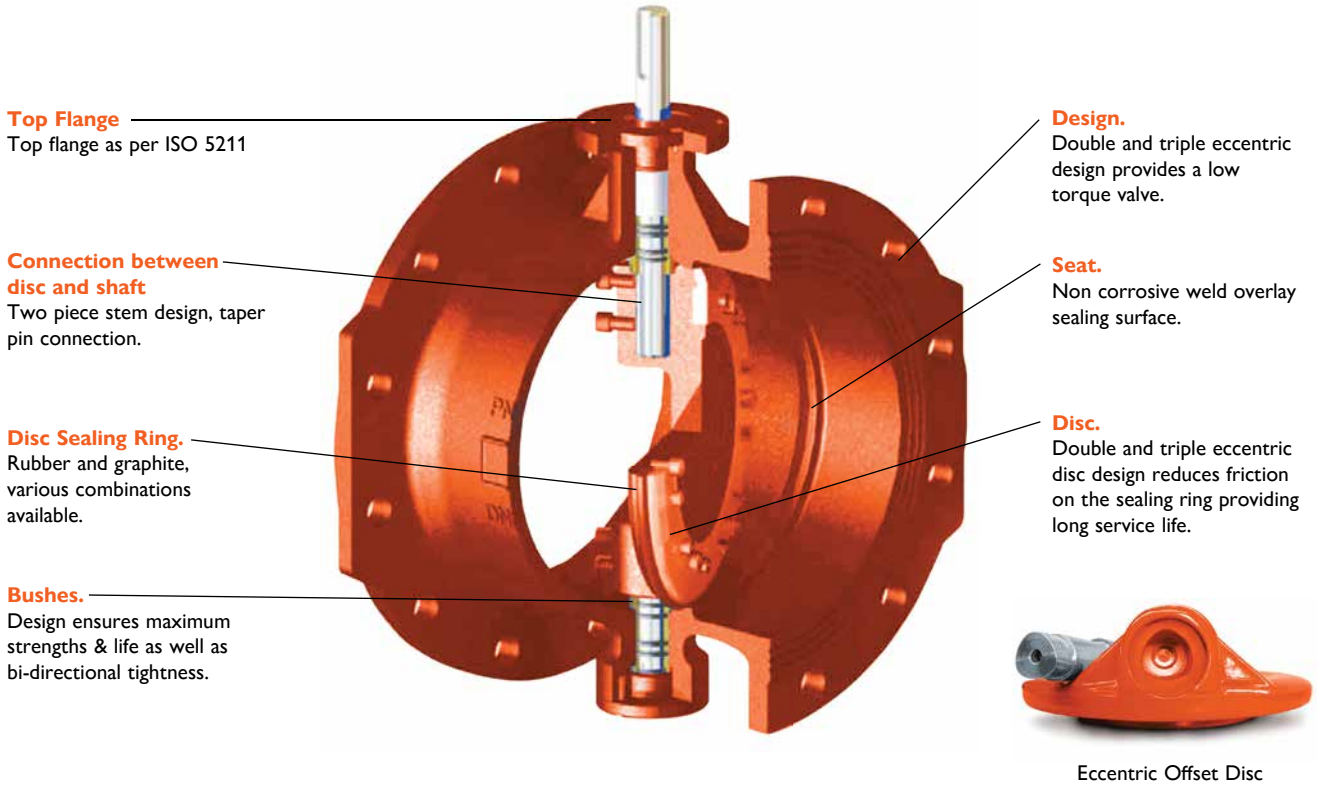

MATERIALS

Name	Material	Specification				Remark
		ASTM	DIN	EN	JIS	
Body	Cast Iron Ductile Iron Carbon Steel Stainless Steel	ASTM A126B	GG25	EN-GJS-250	FC200	
		ASTM A536	GGG40	EN-GJS-400	FCD450	
		A216 WCB	GS-C25	GP 240 GH+N	SCPH 2	
		A351 CF8M	1.4408	BS 970 304 S15	SCS14	
		A351 CF8	1.4301	BS 970 316 S15	SCS13	
Disc	Plated Ductile Iron Aluminium Bronze Stainless Steel Carbon Steel	ASTM A536	GGG40	EN-GJS-400	FCD450	PTFE or Nylon Coated Disc also available
		B148-954	C954	EN 1982 CC491K	ABL2	
		A351 CF8M	1.4408	BS 970 304 S15	SCS14	
		A351 CF8	1.4301	BS 970 316 S15	SCS13	
		A216 WCB	GS-C25	GP 240 GH+N	SCPH 2	
Stem	Carbon Steel	A216 WCB	GS-C25	GP 240 GH+N	SCPH 2	
	Stainless Steel	A276-410	1.4201	BS 970 410-S21	SUS410	
		A276-304	1.4301	BS 970 304 S15	SCS13	
		A276-316	1.4408	BS 970 316 S15	SCS14	
Seat	NBR (Nitrile) EPDM Heat Resistant EPDM Neoprene (CR) Hypalon (CSM) Viton (FKM) Natural Rubber (NR) PTFE Cover NBR Full PTFE Silicon (Q)					-20°C~80°C
						-25°C~110°C
						-25°C~130°C
						-25°C~110°C
						-30°C~120°C
						-20°C~200°C
						-30°C~70°C
Pin	Stainless Steel	A182 F6A	1.4201	BS 970 410-S21	SUS410	
		A182 F304	1.4301	BS 970 304 S15	SCS13	
		A182 F316	1.4408	BS 970 316 S15	SCS14	
Bushing	PTFE					
	Bronze	B62			BC62	
O-Ring	NBR EPDM Viton					-20°C~80°C
						-25°C~110°C
						-20°C~100°C

MODEL HU-B62

Size	DN100-DN2000
General	EN 593, EN 1092
Mounting Pad	ISO 5211
Face to Face	EN 558-1 14 Series, ISO 5752, DIN 3202-F4
Flange Drilling	EN 1092-2PN10/PN16/PN25

Check with APV for available seat ratings on larger sizes.
 Flange drilling according to ASME B16.1, ASME B16.5, ASA 150, BS 4504
 PN10/PN16, BS10 Table D/E, EN 1092 PN2.5~PN25, AS 2129
 Table D/E, AS 4087 PN14, PN16, PN21, JIS10K, ISO 7005.

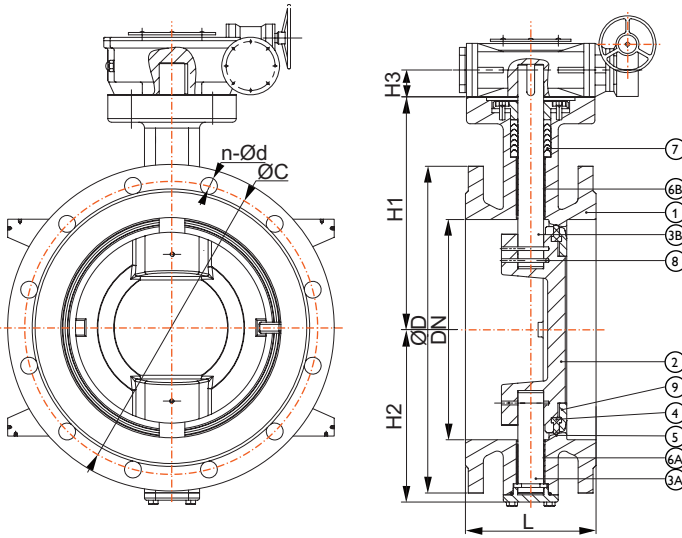
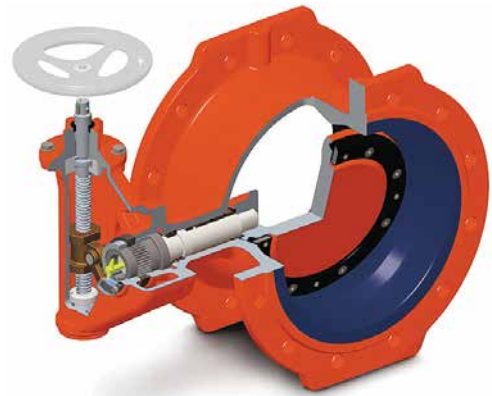

MATERIALS

Parts	Description	Material	Specification
1	Body	Ductile Iron	GGG40
2	Disc	Ductile Iron	GGG40
3	Stem	Stainless Steel	SS420
4	Disc Sealing	EPDM	
5	Body Sealing	Stainless Steel	AISI304
6	Bushing	PTFE+Non-ferrous metal	
7	Packing	EPDM	
8	Pin	Stainless Steel	SS420
9	Retaining Ring	Stainless Steel	AISI304

Typical example only, refer as built drawing.

On Disc - Seat Retention System

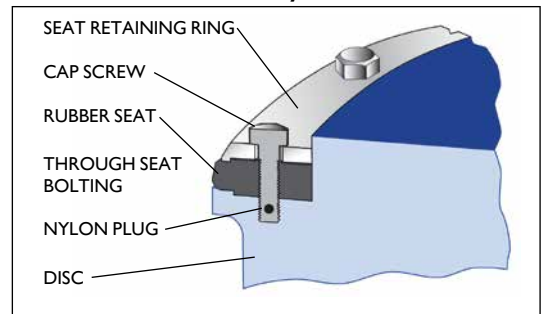

DIMENSIONS (MM)

Size		L	H1	H2	H3	EN 1092-2 PN10			EN 1092-2 PN16			EN 1092-2 PN25		
DN	NPS					ØD	ØC	n-Ød	ØD	ØC	n-Ød	ØD	ØC	n-Ød
100	4"	190	140	115	38	220	180	8-19	220	180	8-19	235	190	8-23
125	5"	200	150	130	38	250	210	8-19	250	210	8-19	270	220	8-28
150	6"	210	160	150	38	285	240	8-23	285	240	8-23	300	250	8-28
200	8"	230	200	187	42	340	295	8-23	340	295	12-23	360	310	12-28
250	10"	250	235	215	42	395	350	12-23	405	355	12-28	425	370	12-31
300	12"	270	264	237	42	445	400	12-23	460	410	12-28	485	430	16-31
350	14"	290	300	270	51	505	460	16-23	520	470	16-28	555	490	16-34
400	16"	310	335	305	51	565	515	16-28	580	525	16-31	620	550	16-37
450	18"	330	360	335	51	615	565	20-28	640	585	20-31	670	600	20-37
500	20"	350	395	370	136	670	620	20-28	715	650	20-34	730	660	20-37
600	24"	390	460	425	136	780	725	20-31	840	770	20-37	845	770	20-41
700	28"	430	535	505	149	895	840	24-31	910	840	24-37	960	875	24-44
800	32"	470	590	560	149	1015	950	24-34	1020	950	24-41	1085	990	24-50
900	36"	510	660	630	185	1115	1050	28-34	1125	1050	28-41	1185	1090	28-50
1000	40"	550	735	705	216	1230	1160	28-37	1255	1170	28-44	1320	1210	28-57
1200	48"	630	840	815	216	1455	1380	32-41	1485	1390	32-50	1530	1420	32-57
1400	56"	710	1010	985	267	1675	1590	36-44	1685	1590	36-50	/	/	/
1600	64"	790	1130	1120	312	1915	1820	40-50	1930	1820	40-57	/	/	/
1800	72"	870	1280	1270	312	2115	2020	44-50	/	/	/	/	/	/
2000	80"	950	1405	1380	326	2325	2230	48-50	/	/	/	/	/	/

Flange drilling according to ASME B16.1, ASME B16.5, ASA 150, DIN2501 PN6/PN10/PN16, BS 4504 PN10/PN16, BS10 Table D/E, EN 1092, AS 2129 Table D/E, JIS10K, ISO 7005 etc.



AUSTRALIAN PIPELINE VALVE®

COMPLETE PRODUCT LINE

“Australian Pipeline Valve produces isolation, control and flow reversal protection products for severe and critical service media in utility, steam, pipelines, oil & gas and process industries. APV valves and pipeline products form the most competitive portfolio in the market.”



SUPER-CHECK®



TORQTURN®

TWIN-LOK®

UNIFLO®



AUSTRALIAN PIPELINE VALVE BRAND RANGE - CATALOGUES

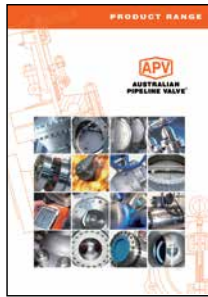

Product Brochure



Ball Valves Floating & Trunnion Mounted

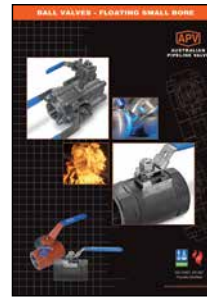

Ball Valves Floating Small Bore

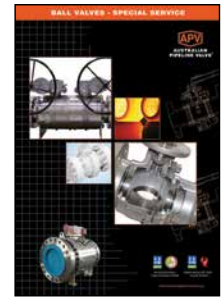

Ball Valves Special Service



Gate, Globe & Check Valves - Cast Steel



Gate, Globe & Check Valves - Forged Steel

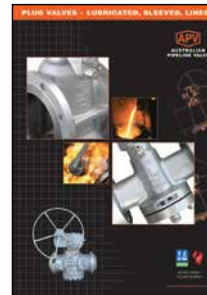

Plug Valves Lubricated, Sleeved & Lined

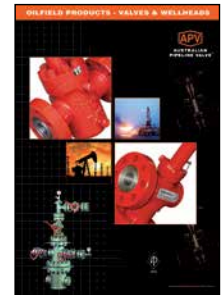

Oilfield Products - Valves & Wellheads

APV FAMILY OF BRANDS RANGE - CATALOGUES



Diamond Gear Gearboxes



Flowturn Ball Valves Multiway & Deadman



Flowturn Gate, Globe & Check Valves



Flowturn Instrument Valves

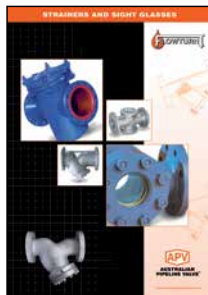

Flowturn Strainers & Sight Glasses



Steamco Steam Valves



Supercheck Wafer Check Valves



Superseal Butterfly Valves

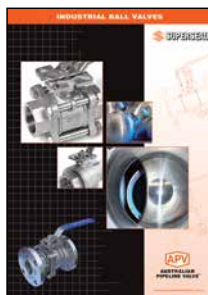

Superseal Industrial Ball Valves



Torqturn Actuators

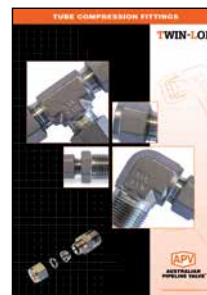

TwinLok Tube Fittings

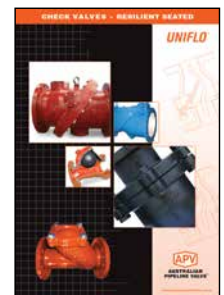

Uniflo Check Valves

Contact us for your local stockist/distributor



AUSTRALIAN PIPELINE VALVE®

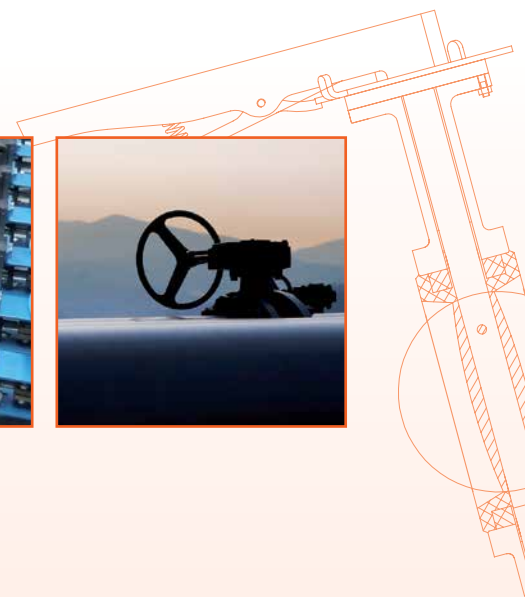

www.australianpipelinevalve.com.au

LOCAL DISTRIBUTOR

Global Supply Line is distributor & stockist, supplying worldwide.
Full stock list on line www.globalsupplyline.com.au

Contact email: sales@globalsupplyline.com.au



API 622 2011 2nd Edition
Fugitive Emission Certified



API 622 2011 2nd Edition
Endurance Test Certified

QUALITY ASSURANCE AND CERTIFICATION

We are continually improving all facets of quality assurance. Full metallurgical and test certificates are always supplied for all pressure retaining parts, we also provide it on all major trim components.

We have endeavoured to provide a broad outline of our range and capabilities. Because we are continually developing new products for our customers this catalogue will, to some extent be incomplete. This catalogue is a general overview only, individual drawings and data sheets can be furnished on request.

If you have any requirement in the field of valves, please contact us for a prompt response. Continuous development of Australian Pipeline Valve products may necessitate changes in the design or manufacturing processes. Australian Pipeline Valve reserves the right to effect any such changes without prior notice.

