

COLOSSUS

HIGH PERFORMANCE DOUBLE ECCENTRIC BUTTERFLY VALVES

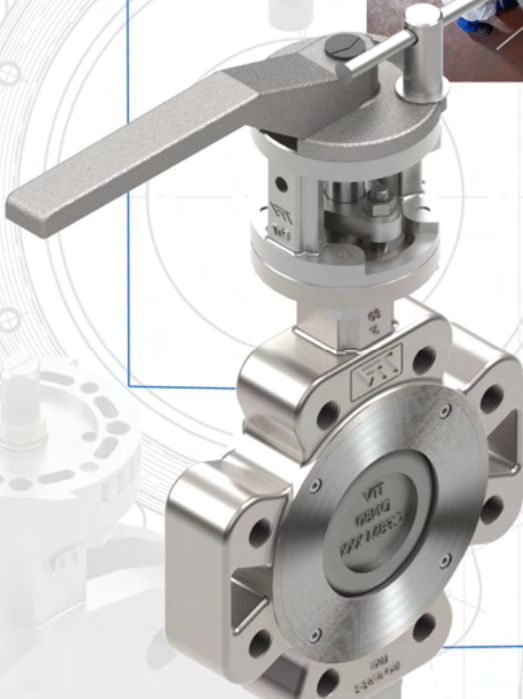

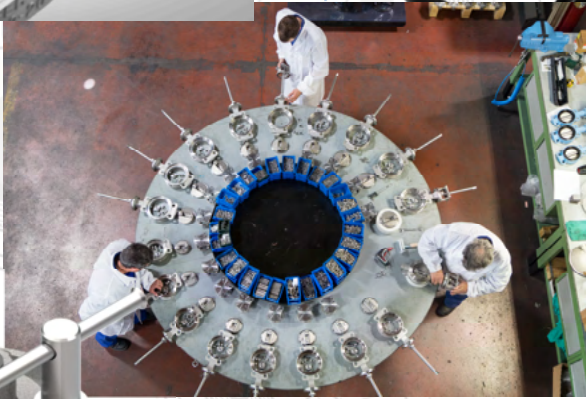
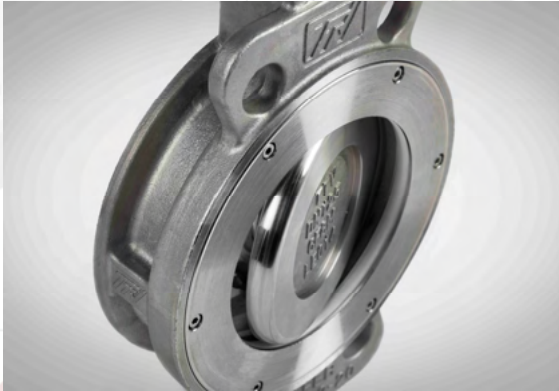
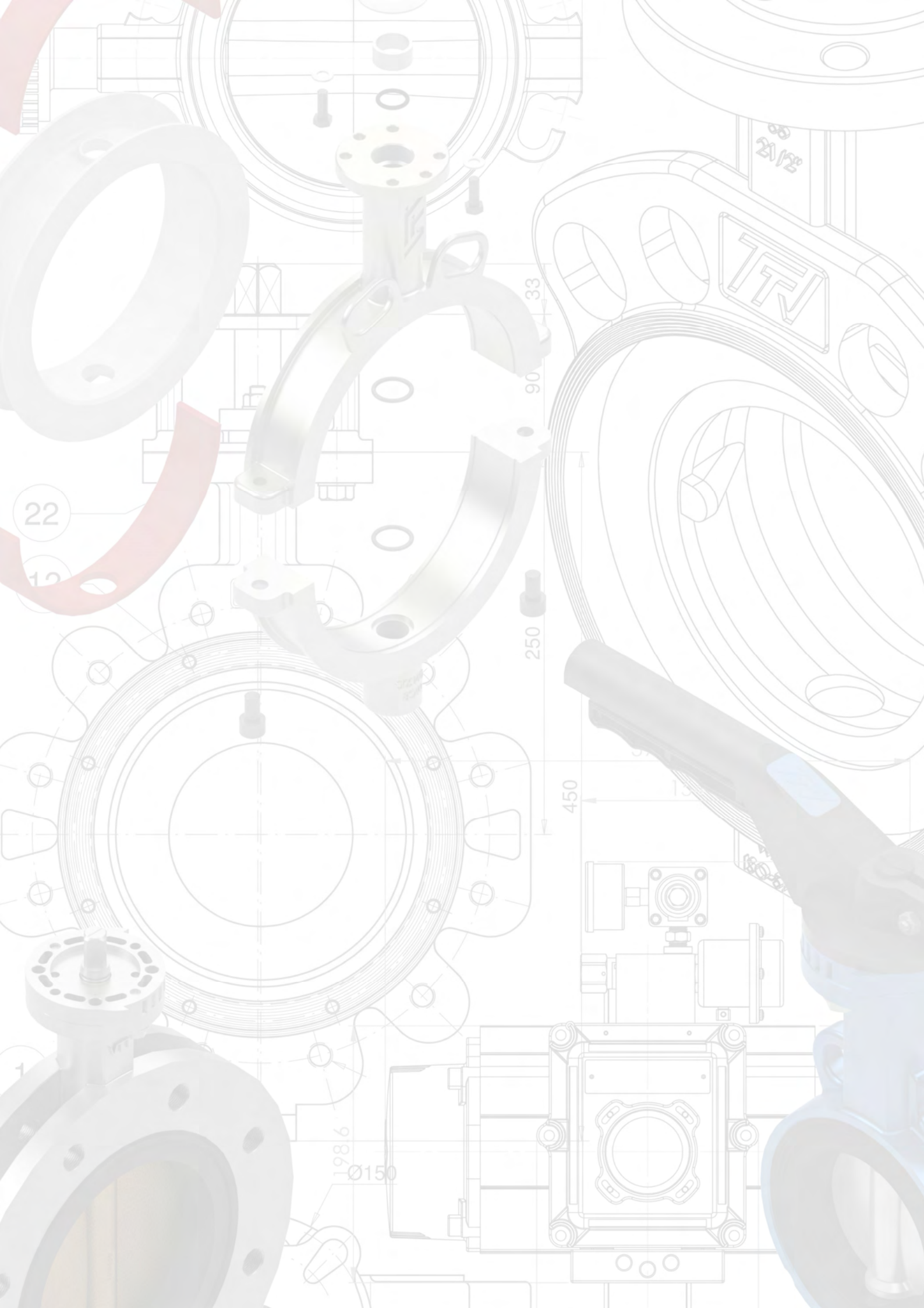

22

12

33

250

450

1986
Ø150

INDEX

1. SPECIFICATIONS
 - 1.1. 2-Eccentric design characteristics
 - 1.2. General characteristics.
 - 1.3. Standard of production.
 - 1.4. Design specification
 - 1.5. Materials
2. ASSEMBLY
3. RPTFE SEATED VALVE MATERIALS
4. RPTFE + SS316 SEATED VALVE MATERIALS
5. METAL SEAT VALVE MATERIALS
6. SPECIAL EXECUTION FOR HIGH TEMPERATURE
7. DIMENSIONS: Wafer, Lug and Flanges (S20)
8. DIMENSIONS: Double Flange (S13)
9. OPERATING LEVER AND PNEUMATIC ACTUATOR ACTIVATION
10. COLOSSUS 2-ECCENTRIC VALVE ACTUATING TORQUE
11. FLOW COEFFICIENT (CV)
 - 11.1. CHARACTERISTIC CURVE
12. CAVITATION
13. INSTALLATION
 - 13.1. Installation steps
14. CONNECTION, FLANGES AND SCREWS
15. MAINTENANCE
 - 15.1. Lubrication
 - 15.2. Packing
16. VALVE UNINSTALLING ASSEMBLY AND DISASSEMBLY
 - 16.1. VALVE UNINSTALLING
 - 16.2. Disassembly
 - 16.3. Assembly
17. SPARE PARTS
18. PRESSURE | TEMPERATURE
19. FLUID SIMULATION
20. RESISTANCE STUDY OF MATERIALS SUBJECTED TO PRESSURE
21. WAFER SCREWS | PN10 - PN16 - PN25
22. WAFER SCREWS | ANSI150 - ANSI300
23. LUG SCREWS | PN10 - PN16 - PN25
24. LUG SCREWS | ANSI150 - ANSI300
25. VALVE CODIFICATION

1. SPECIFICATIONS

Due to the valve shaft double movement, the disc rotation movement is eccentric in the seat. The circular rotation movement of the valve disc becomes into an elliptical movement. So, we get the disc to be in contact with the seat just few degrees before the valve is completely closed.

1.1. 2-Eccentric design characteristics

- Longer service life, minimum friction between the disc and the seat.
- In the closed valve position, the disc strength in the seat assures a complete tightness regardless the pressure.
- Self-sealing mechanism to assure a watertight closing and low operating torque.
- The displaced shaft design allows an easy seat replacement without disassembling the shaft and other internal components, with a fast in-situ maintenance.
- The Colossus 2-eccentric butterfly valves offer the high performance of the ball and gate valve with low cost and light weight characteristics of the butterfly valves design.

1.2. General characteristics.

- Design available for wafer, lug, flange S20 and double flange S13.
- Steel or stainless steel body
- The same construction, 3 seats types:
Soft: 100% PTFE / R-PTFE + steel body from -29°C to 220°C.
+ stainless steel body from -220°C to 50°C.
Metal: INCONEL + steel body from -29°C to 220°C (to 380°C with extension split)
+ stainless steel body from -50°C to 220°C (to 600°C extension split).
- Fire Safe: R-PTFE y AISI 316 + steel body from -29°C to 220°C.
+ stainless steel body from -220°C to 50°C.
- Stainless steel disc.
- Valve construction with R-PTFE closure suitable for vacuum.
- Stainless steel shaft.
- Easy seat replacement in all cases.
- Inspection and tests: ISO 5208 / API 598
- Work pressure: to 25 bar.
- Flange
ISO 5752, 20 serie
EN 593
DIN - PN10 / 16 / 25
ANSI 150Lbs / 300Lbs
- Actuator assembly: ISO 5211

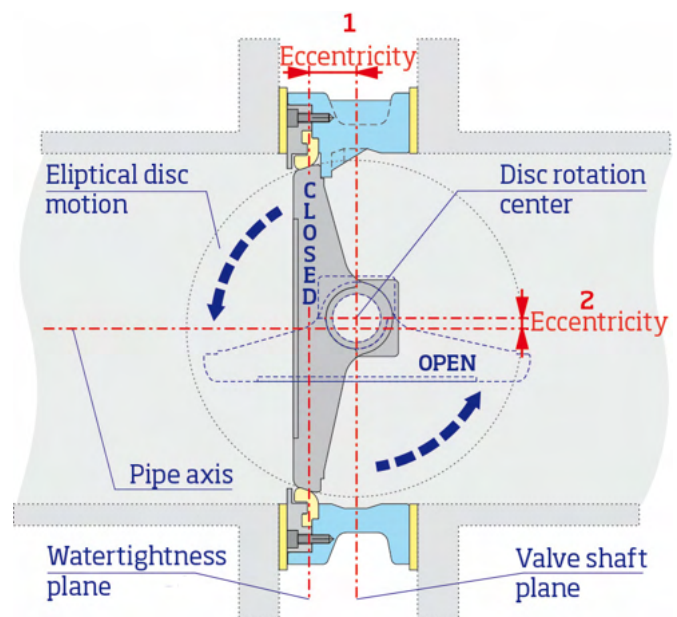

- Design and construction:
API 609
ASME B16.34
MSS SP-67
EN 593
Nace MR 0175

1.3. Standard of production.

	<i>End connection</i>	<i>Wafer and Lug</i>	<i>Flange S20</i>	<i>Flange S13</i>
<i>Standard of design</i>	Standard of TTV	API 609 & ANSI/ASME B16.34 API 607 (Fire Safe)	API 609 & ANSI/ASME B16.34	API 609 & ANSI/ASME B16.34
	Optional configurations	EN 593	EN 593	EN 593
<i>Face to Face</i>	Standard of TTV	API 609, B Category MSS-SP-68 ANSI/ASME b16.1 ISO 5752 Table 1 & BS 5155	ISO 5752 EN 593 ANSI/ASME b16.1 (Only DN50 and DN65)	ISO 5752 EN 593 ANSI/ASME b16.1 (Only DN50 and DN65)
	Optional configurations	DIN 3202 ISO 5752 EN 593	DIN 3202 ISO 5752 EN 593	DIN 3202 ISO 5752 EN 593
<i>Shaft connection</i>	Standard of TTV	ANSI/ASME B16.5 CL 150, 300, 600 ANSI/ASME B16.47, A Serie CL150, 300 MSS-SP-44: CL150, 300, 600 API 605: CL150, 300	ANSI/ASME B16.5 CL 150, 300, 600 ANSI/ASME B16.47, A Serie CL150, 300 MSS-SP-44: CL150, 300, 600 API 605: CL150, 300	ANSI/ASME B16.5 CL 150, 300, 600 ANSI/ASME B16.47, A Serie CL150, 300 MSS-SP-44: CL150, 300, 600 API 605: CL150, 300
	Optional configurations	JIS B 2210 10K, 16K, 20K, 30K, 40K DIN 2501, ISO 7005-1 PN10, PN16, PN20, PN25, PN40	JIS B 2210 10K, 16K, 20K, 30K, 40K DIN 2501, ISO 7005-1 PN10, PN16, PN20, PN25, PN40	JIS B 2210 10K, 16K, 20K, 30K, 40K DIN 2501, ISO 7005-1 PN10, PN16, PN20, PN25, PN40
<i>Tests</i>	Standard of TTV	API 598 ANSI/ASME B16.34 BS 1560 EN 593	API 598 ANSI/ASME B16.34 BS 1560 EN 593	API 598 ANSI/ASME B16.34 BS 1560 EN 593
	Optional configurations	JIS B 2203, 2201 DIN 3230 ISO 7005 FCI 70-2 ANSI/ASME B16.104 MSS-SP 61 EN 12266	JIS B 2203, 2201 DIN 3230 ISO 7005 FCI 70-2 ANSI/ASME B16.104 MSS-SP 61 EN 12266	JIS B 2203, 2201 DIN 3230 ISO 7005 FCI 70-2 ANSI/ASME B16.104 MSS-SP 61 EN 12266

1.4. Design specifications

Two designs available, in both the flanges face is finished with 125-200 AAHH compatible with spiral or flat gaskets.

- Standard retainer fixed by screws th the valve, final tightening is get with the valve assembled in the pipeline
- Threaded retainer, allows a largesealing surface reducing the rish of leakage, faste replacemeat and maintenance. Exclusive square thread design ensures continuous sealing.

1.5. Materials

1.5.1. The following materials will be used for the stainless steel valves:

- Body: ASTM A351 CF8M
- Disc: ASTM A351 CF8M

1.5.2. The following materials will be used for carbon steel valves:

- Body: ASTM A216 WCB +silver heat-resistant paint (30 micron).
- Disc: ASTM A351 CF8M

1.5.3. The following materials will be used for the shafts:
ASTM A182 F316 o F431.

1.5.4.For the seats:

- Soft seat: R-PTFE (PTFE + 25% Fiber Glass)
100% PTFE.

Temperature: -50°C to +220°C

Tightness Class VI, Leakage "0", PN10/16/25.

In this type of seats, the retainer (5) holds and isolates the polymer (4) from the direct contact with the flange in the pipe, keeping the seat in its static position without deformation.

Chevron Packings at the shaft, type 60°, in PTFE material and as a special execution for this type of seats in graphite. Seat assembly 100 % PTFE, packing will be in PTFE and the friction bushings in stainless steel, covered with PTFE.

This valve model 100% PTFE can be used in drinking water, vegetals, oils or food installations.

The R-PTFE seat can be used with all kinds of chemical products, except alkaline metals in the elemental state, chlorine tri-fluoride, fluorine at high temperature and pressure or its derivates, concentrated nitric acids and sulfuric acid with acid content over 65%.

In general, it is recomended its use in very aggresive chemical tracks and where different types of products will flow, as:

- | | |
|------------------|---------------------------|
| • Vaccum service | • Hydrocarbon derivatives |
| • Chemicals | • Steam |
| • Oil products | • Air |
| • Ethylene | • Saturated water |
| • LPG / LNG | • Sea water |

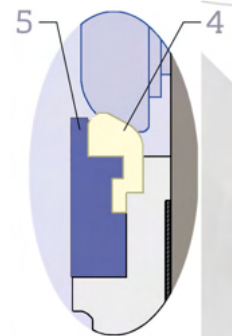

➤ Metal seat:

Temperature: -50°C to +360°C

Tightness Class V, PN 10/16/25.

Metal seat (4) that depending on the applications it is flexible. The ball disc surface for this type of seats it is coated in chrome and, depending on the cases, it could be stellite.

Packings at the graphite shaft and stainless friction bushing coated in a PTFE and graphite alloy.

The metal seat complies with the BS 6755 part 2 or API 6FA/607 (fire safe).

It is normally used in services in which the R-PTFE is not appropriate, whether for the temperature or any of its exceptions.

Besides the described applications for the R-PTFE, it is also valid for:

- | | |
|---------------------|---------------------|
| • Saturated steam | • Corrosive liquids |
| • Lagging gas | • Thermic oil |
| • Bitumen / Asphalt | • Cogeneration |

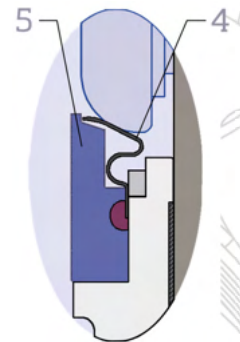

➤ FIRE SAFE seat:

Temperature: -50°C to +220°C

Optional design planned for an additional metal seat (AISI 316) that ensure tightness (4a) when the seat of soft material (4) is been destroyed by the fire.

The seal Fire Safe has been subjected to fire tests and is qualified to comply with the most severe requirements of the API 607. This unique design provides fire test capacities regardless the flow direction.

It is recommended to be used in fire, abrasive, mud and steam protection installations.

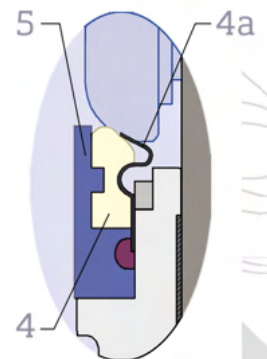

2. ASSEMBLY

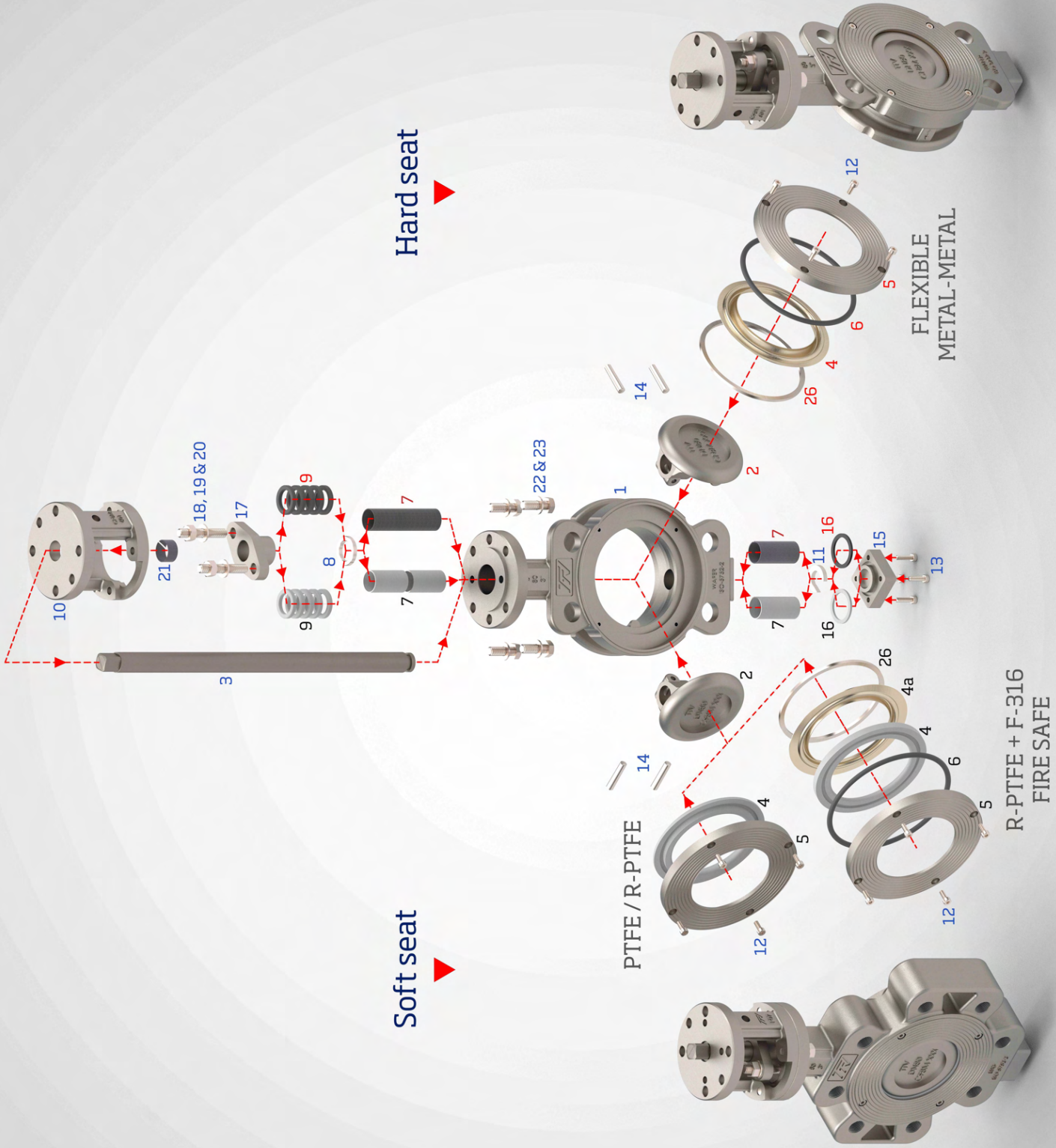

As shown in the picture, all valve COLOSSUS seats are assembled in the same construction and both share the components described in the table. "general parts list". The group of materials that complete each model directly depends on the seat type and are described in the related lists.

General parts list

<i>Item</i>	<i>Description</i>	<i>Material</i>
1	Body	CF-8M or A216 WCB
3	Shaft	F-316 / A-431
8	Press washer	F-316
10	Structural bracket	CF-8M or A216 WCB
11	Safety washer	F-316
12	Screw	A4 (F-316)
13	Bottom cap screws	A4 (F-316)
14	Bolt	A4 (F-316)
15	Bottom cap	CF-8M or A216 WCB
17	Upper gland	CF-8M
18	Threaded bolt	A4 (F-316)
19	Nut	A4 (F-316)
20	Washer	A4 (F-316)
21	Guide bracket bushing	Inox + PTFE + Gr
22	Hexagonal screw	A4 (F-316)
23	Flat washer	A4 (F-316)

R-PTFE parts list: soft seat

<i>Item</i>	<i>Description</i>	<i>Material</i>
2	Disc	CF-8M (rectified and polished)
5	Retainer	F-316L
R-PTFE		
4	R-PTFE seat	PTFE + 25% F. Glass
7	Guide bushing	Inox + PTFE + Gr
9	Packing	PTFE
16	Gasket cap	PTFE
PTFE		
4	R-PTFE seat	PTFE + 25% F. Glass
7	Guide bushing	Inox + PTFE
9	Packing	PTFE
16	Gasket cap	PTFE
R-PTFE / FIRE SAFE		
4	R-PTFE seat	PTFE + 25% F. Glass
4a	Flexible seat	F-316L
6	Gasket	Graphite
7	Guide bushing	Inox + PTFE + Gr
9	Packing	Graphite
16	Gasket cap	Graphite
26	Reinforcement ring	F-316L

Metal seat: parts list

<i>Item</i>	<i>Description</i>	<i>Material</i>
2	Disc	CF-8M + 40 µm Cr. Hard (polished)
4	Seat (flexible sheet)	Inconel
5	Retainer	F-316L
6	Gasket	Graphite
7	Guide bushing	Inox + PTFE + Gr
9	Packing	Graphite
16	Bottom cap gasket	Graphite
26	Reinforcement ring	F-316L

3. PTFE / RPTFE SEATED VALVE MATERIALS (ANSI CLASS 150LB, ISO PN10-PN25)

- Shaft (3): Design in one piece with square (ISO 5211).
- Packing (9): Diverse Chevron PTFE layers.
- RPTFE seat (4): Tightness to all pressures. (The valve has to be desinstalled with a retention ring in case of end of line)
- Gasket for the shaft (11): With a no removal and no static system.
- Bushing (7): Superior and inferior bushing made of Inox+PTE+Gr.
- Support (10): Microfusion. According to ISO 5211.
- Packing system for leakage emmissions: ISO 15848.
- Botton cover (16) gasket to preveat leaks.
- Optional assembly with 100% PTFE seat and PTFE coated bushings for food installations.

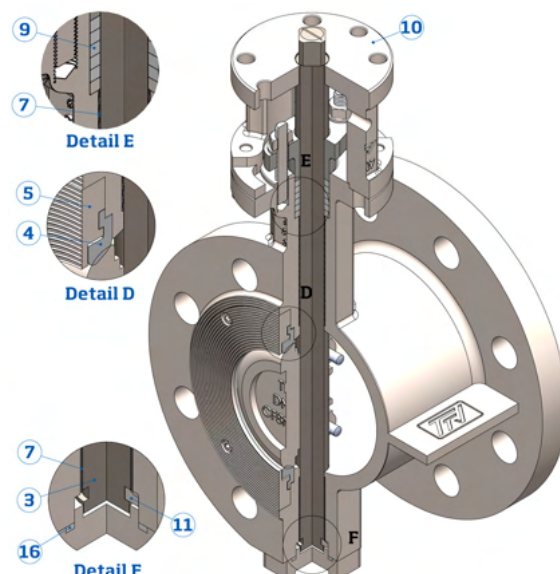

4. RPTFE + SS316 SEATED VALVE MATERIALS (ANSI CLASS 150LB, ISO PN10-PN25) **FIRE SAFE**

- Shaft (3): Design on one piece with square (ISO 5211).
- Packing (9): The praphite packing ensures leakage 0 in case of fire.
- Fireproof seat (4a, 4): The bidirectional design of both the soft. Leakage 0 seat and the metal-metal seat (4a) for fire exposure complies with the fireproof needs required. (The valve has to be installed with a retention ring in case of end of line)
- Gasket for the shaft (11): With a no removal and no static system.
- Bushing (7): Superior and inferior bushing made of Inox+PTE+Gr.
- Support (10): Microfusion. According to ISO 5211.
- Packing system for leakage emmissions: ISO 15848.
- Botton cover (16) gasket to preveat leaks.
- Reinforcemeat ring (26) that improves the performance of the metal seat in the fire safe design.

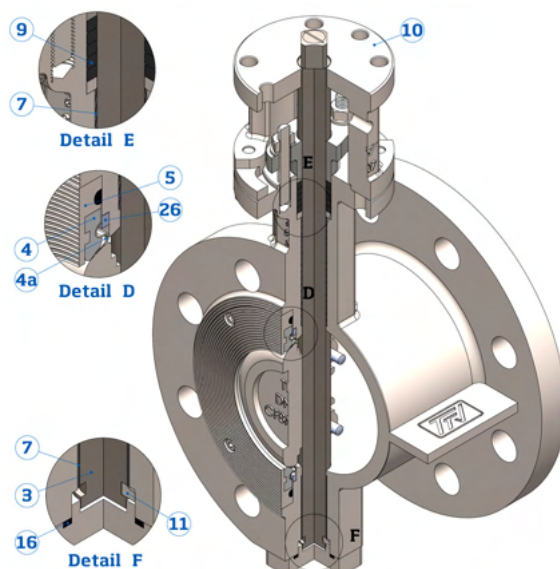

5. VALVE MATERIALS FOR THE METAL SEAT (ANSI CLASS 150LB, ISO PN10-PN25)

- Shaft (3): Design on one piece with square (ISO 5211).
- Packing (9): Compatible graphite packing with high temperature service.
- Metal seat (4): Leakage 0 autosealed metal seat will have category Class IV according to ANSI/ FCI 70-2 or higher. (The valve has to be installed with a retention ring in case of end of line)
- Gasket for the shaft (11): With a no removal and no static system.
- Bushing (7): Superior and inferior bushing made of Inox+PTE+Gr.
- Support (10): Microfusion. According to ISO 5211.
- Packing system for leakage emmissions: ISO 15848.
- Botton cover (16) gasket to preveat leaks.
- Reinforcemeat ring (26) that improves the performance of the metal seat.

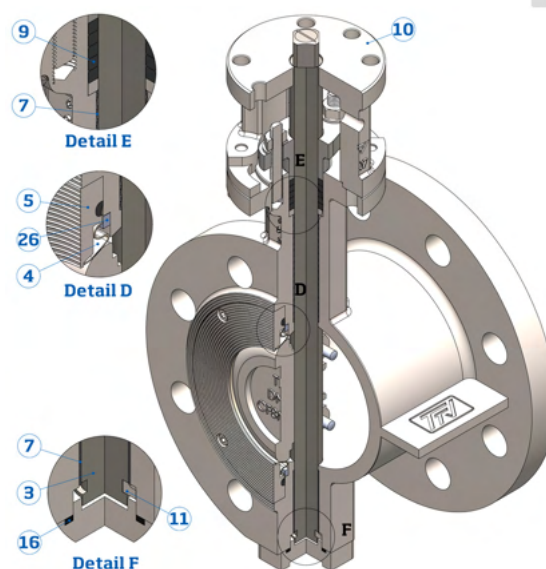

6. SPECIAL EXECUTION FOR HIGH TEMPERATURE

Extension split installation in valves with metal closing up to 600°C. Design produced in microfusion of one single piece (no weld). It is recommended to install the extension split from 220°C.

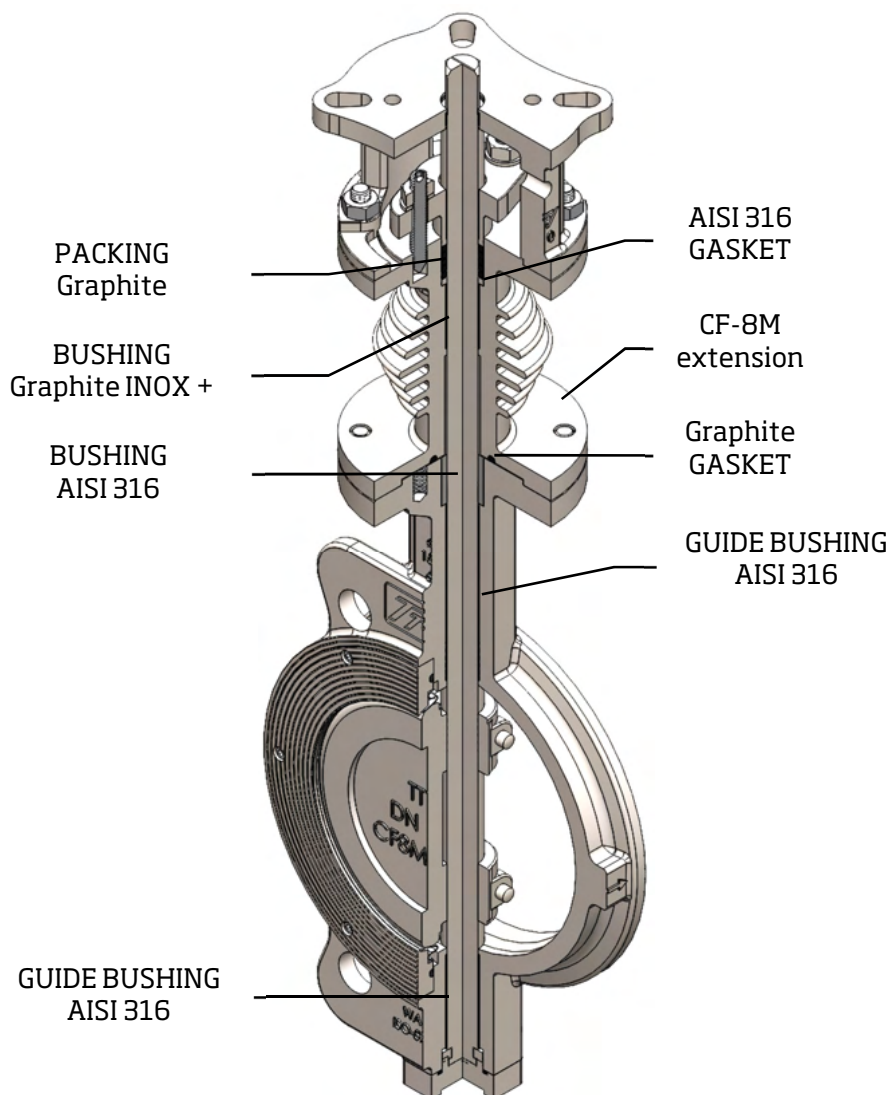
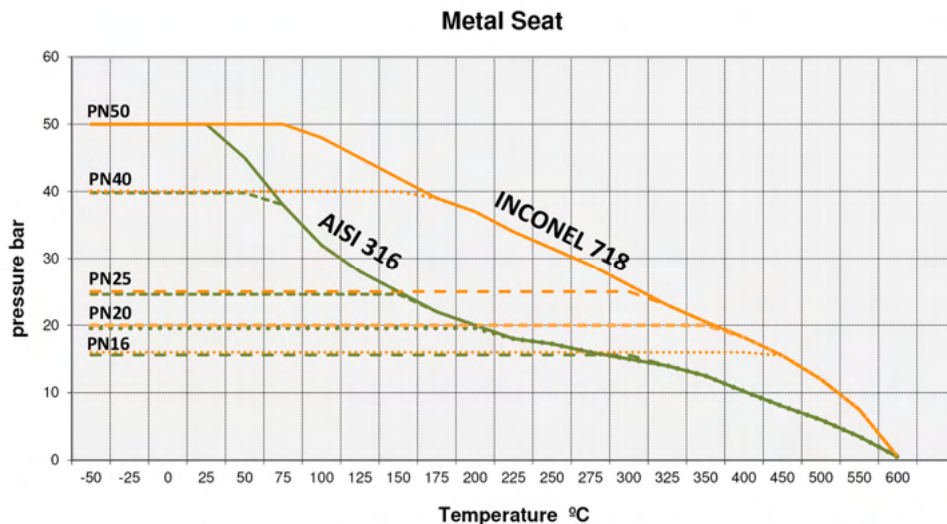

DN	H
40	124
50	124
65	124
80	124
100	124
125	135
150	135
200	150
250	175
300	175
350	175
400	200
450	200
500	250
600	250

7. DIMENSIONS: Wafer, Lug and Flanged (S20)

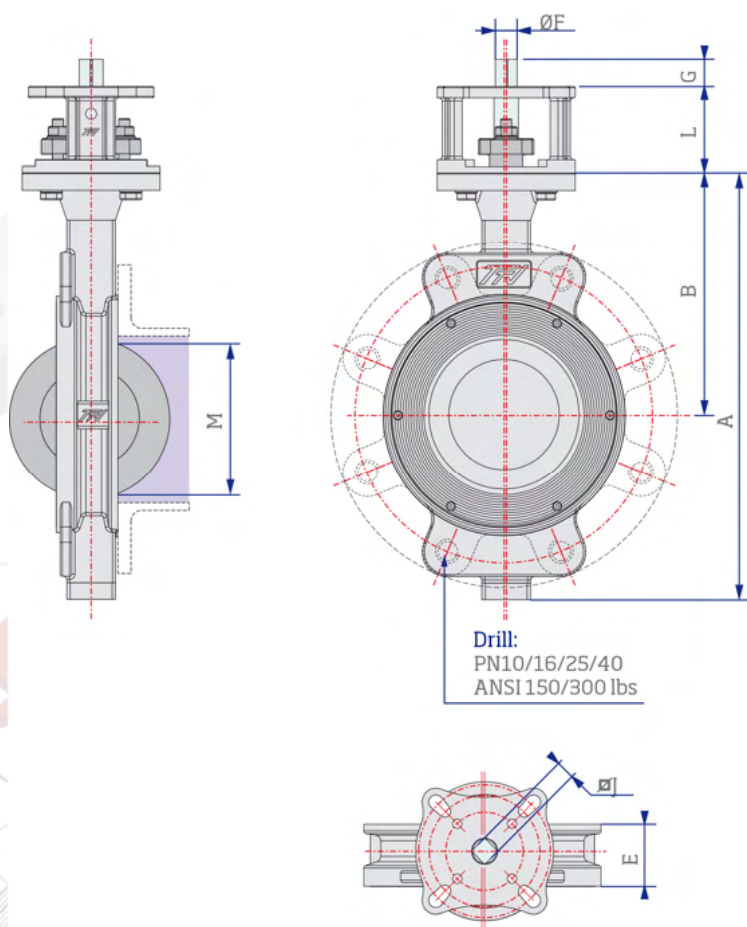

Lug



Wafer



Flange (S20)



Changes expected without notice. The pictures may not be the real representation from manufacturing.

DN		A	B	E	F	G	J	L	M	ISO 5211	Weight (Kg)		
Mm	inch										Wafer	Lug	Flanges
40	1 ½"	181	121	33	10	14	9*	70	24	F05-F07	3,2	4	7
50	2"	218	128	43	12	14	9*	70	32	F05-F07	4,6	6	6
65	2 ½"	228	140	46.5	14	14	11	70	48	F05-F07	5,3	7	7
80	3"	259	148	47	17	15	14	70	70	F05-F07	6,4	9	9
100	4"	295	169	52	17	18	14	70	90	F05-F07	8	14	14
125	5"	350	200	56	21	22	17*	80	116	F07-10-12	14	18	18
150	6"	388	220	56	21	24	17*	80	141	F07-10-12	16	20	22
200	8"	450	250	63	26.5	32	22*	90	187	F10-12-14	26	35	39
250	10"	523	286	71	26.5	39	22*	106	226	F12-14-16	42	49	54
300	12"	606	328	78	33	50	27*	106	274	F12-14-16	58	65	71
350	14"	661	355	78	36	50	27*	106	329	F12-14-16	64	86	92
400	16"	704	370	102	50	80	-	106	377	F12-14-16	103	145	150
450	18"	755	400	114	50	80	-	106	423	F14-16	125	169	175
500	20"	830	450	127	60	80	-	120	445	F14-16	162	225	236
600	24"	970	510	154	60	90	-	120	536	F14-16	271	370	382

*Standard shaft, it is possible to adapt it to ISO 5211 and maximum torque

8. DIMENSIONS: Double Flange (S13)

Double flange (S13)

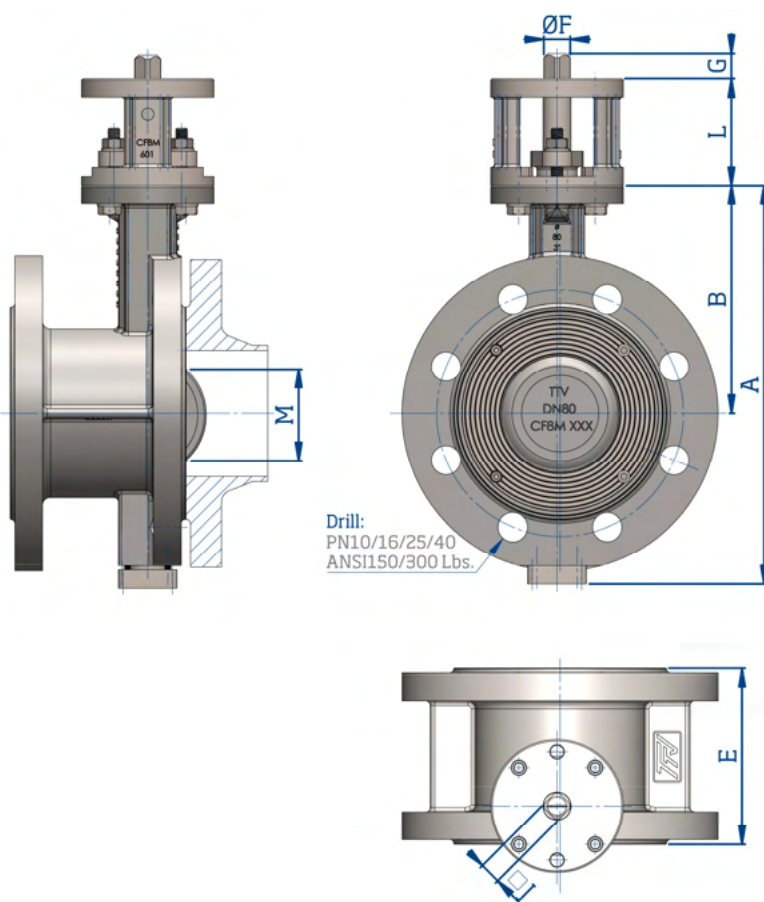

Changes expected without notice. The pictures may not be the real representation from manufacturing.

DN		A	B	E	F	G	J	L	M	ISO 5211	Weight (Kg)
mm	inch										S13
40	1 1/2"	181	121	106	10	14	9*	70	24	F05-F07	8
50	2"	218	128	108	12	14	9*	70	32	F05-F07	9
65	2 1/2"	228	140	112	14	14	11	70	48	F05-F07	10
80	3"	259	148	114	17	15	14	70	70	F05-F07	12
100	4"	295	169	127	17	18	14	70	90	F05-F07	16
125	5"	350	200	140	21	22	17*	80	116	F07-10-12	21
150	6"	388	220	140	21	24	17*	80	141	F07-10-12	35
200	8"	450	250	152	26.5	32	22*	90	187	F10-12-14	57
250	10"	523	286	165	26.5	39	22*	106	226	F12-14-16	90
300	12"	606	328	178	33	50	27*	106	274	F12-14-16	139
350	14"	661	355	190	36	50	27*	106	329	F12-14-16	205
400	16"	704	370	216	50	80	-	106	377	F12-14-16	209
450	18"	755	400	222	50	80	-	106	423	F14-16	370
500	20"	830	450	229	60	80	-	120	445	F14-16	496
600	24"	970	510	267	60	90	-	120	536	F14-16	643

*Standard shaft, it is possible to adapt it to ISO 5211 and maximum torque

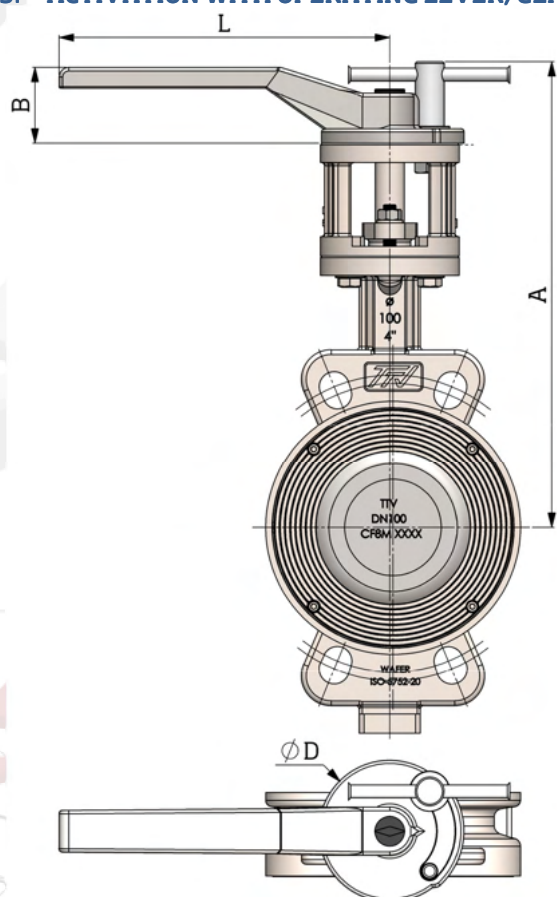
9. ACTIVATION WITH OPERATING LEVER, GEARBOX AND PNEUMATIC ACTUATOR

DN		COLOSSUS R-PTFE / METAL / FIRE SAFE OPERATING LEVER				Weight (Kg)	
mm	inch	A	B	D	L	Wafer	Lug
40	1 ½"	240	46.5	88	205	3.5	4.3
50	2	247	46.5	88	205	4.9	6.3
65	2 ½"	259	46.5	88	205	5.6	7.3
80	3	267	46.5	88	205	6.7	9.3
100	4	288	46.5	88	330	8.5	14.5
125	5	329	46.5	88	330	14.5	18.5
150	6	349	46.5	88	330	16.5	20.5

DN		GEARBOX	COLOSSUS R-PTFE / METAL / FIRE SAFE GEARBOX					Weight (Kg)	
mm	inch		A	B	C	D	L	Wafer	Lug
40	1 ½"	TTV-AM1	219	100	50	140	115	4.6	5.4
50	2	TTV-AM1	225.5	100	50	140	115	6	7.4
65	2 ½"	TTV-AM1	237.5	100	50	140	115	7.2	8.4
80	3	TTV-AM1	245.5	100	50	200	120	8.2	10.8
100	4	TTV-AM1	266.5	100	50	200	120	9.8	15.8
125	5	TTV-AM2	322	142	60	300	223	18	22
150	6	TTV-AM2	342	142	60	300	223	20	24
200	8	TTV-AM2	382	142	60	300	223	30	39
250	10	TTV-AM3	443	185	80	400	325	51.5	58.5
300	12	TTV-AM3	485	185	80	400	325	67.5	74.5
350	14	TTV-AM3	512	185	80	400	325	73.5	95.5
400	16	ARC10	532	200	86	600	381	122	164
450	18	ARC11	554	220	104.5	600	402	152	196
500	20	ARC12	625	285	130	700	447	200	263
600	24	ARC12	685	285	130	700	447	309	408

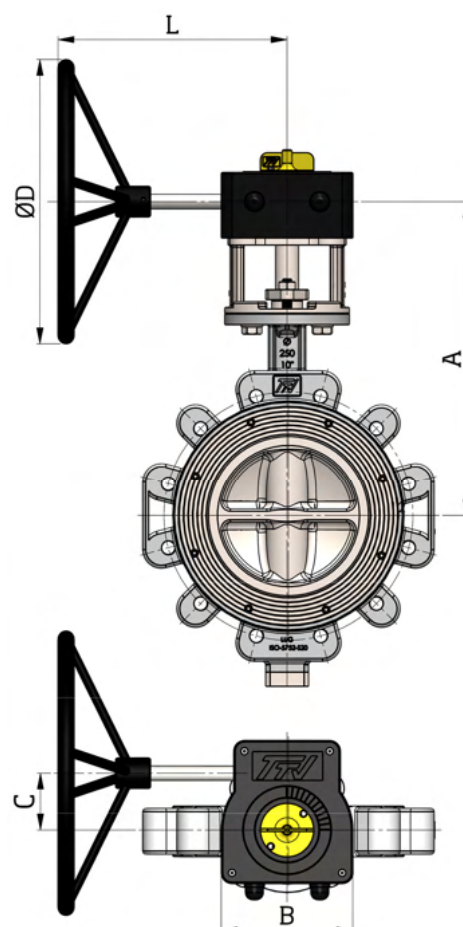

COLOSSUS R-PTFE																	
DN		PN10/16/20/25 ACTUATOR				PN10/16 ACTUATOR				PN20 ACTUATOR				PN25 ACTUATOR			
mm	inch	ADA	A	B	C	ASR	A	B	C	ASR	A	B	C	ASR	A	B	C
40	1½"	40	306	91	145	80	328	111	217	80	328	111	217	80	328	111	217
50	2"	40	313	91	145	80	335	111	217	80	335	111	217	80	335	111	217
65	2½"	40	325	91	158	80	347	111	217	80	347	111	217	80	347	111	217
80	3"	80	355	111	177	200	383	135.5	299	200	383	135.5	299	200	383	135.5	299
100	4"	130	386	122	196	200	404	135.5	299	300	421	152.5	348.5	300	421	152.5	348.5
125	5"	200	445	135.5	225	300	462	152.5	348.5	300	462	152.5	348.5	300	462	152.5	348.5
150	6"	300	482	152.5	273	500	499	173	397	850	521	191.5	473	850	521	181.5	473
200	8"	500	539	173	304	850	561	191.5	473	1200	589	212.5	560	1200	589	212.5	560
250	10"	850	613	191.5	372	1200	641	212.5	560	1750	672	242.5	601	1750	672	242.5	601
300	12"	1200	683	212.5	439	1750	714	242.5	601	1750	712	242.5	601	2100	747	276.5	702
350	14"	1750	741	242.5	461	2100	741	276.5	702	2100	741	276.5	702	2500	844	356	738
400	16"	2100	803	276.5	461	2500	873	356	738	2500	873	356	738	2500	873	356	738

COLOSSUS METAL																	
DN		PN10 ACTUATOR				PN16 ACTUATOR				PN20 ACTUATOR				PN25 ACTUATOR			
mm	inch	ADA	A	B	C	ADA	A	B	C	ADA	A	B	C	ADA	A	B	C
40	1½"	40	306	91	158	40	306	91	158	40	306	91	158	40	306	91	158
50	2"	40	313	91	158	40	313	91	158	40	313	91	158	80	335	111	177
65	2½"	40	325	91	158	40	325	91	158	80	347	111	177	80	347	111	177
80	3"	80	355	111	177	80	355	111	177	130	365	122	196	130	365	122	196
100	4"	130	386	122	196	130	386	122	196	130	386	122	196	130	386	122	196
125	5"	200	445	135.5	225	200	445	135.5	225	300	462	152.5	273	500	479	173	304
150	6"	500	499	173	304	500	499	173	304	850	521	181.5	372	1200	549	212.5	439
200	8"	500	539	173	304	850	561	191.5	372	1200	589	212.5	439	1200	589	212.5	439
250	10"	850	613	191.5	372	1200	641	212.5	439	1200	641	212.5	439	1750	672	242.5	461
300	12"	1750	714	242.5	461	2100	747	276.5	510	2100	747	276.5	510	2500	817	356	518
350	14"	1750	741	242.5	461	2100	774	276.5	510	2500	844	356	518	2500	844	356	518
400	16"	2100	803	276.5	510	2100	803	276.5	510	2500	873	356	518	-	-	-	-

COLOSSUS METAL																	
DN		PN10 ACTUATOR				PN16 ACTUATOR				PN20 ACTUATOR				PN25 ACTUATOR			
mm	inch	ASR	A	B	C	ASR	A	B	C	ASR	A	B	C	ASR	A	B	C
40	1½"	80	328	111	217	80	328	111	217	80	328	111	217	80	328	111	217
50	2"	80	335	111	217	80	335	111	217	80	335	111	217	130	345	122	258
65	2½"	80	347	111	217	130	357	122	258	130	357	122	258	200	375	135.5	299
80	3"	130	365	122	258	200	383	135.5	299	200	383	135.5	299	300	400	152.5	348.5
100	4"	200	404	135.5	299	200	404	135.5	299	200	404	135.5	299	300	421	152.5	348.5
125	5"	300	462	152.5	348.5	500	479	173	397	850	501	191.5	473	1200	529	212.5	560
150	6"	850	521	181.5	473	850	521	191.5	473	1200	549	212.5	560	1750	580	242.5	601
200	8"	1200	589	212.5	560	1750	620	242.5	601	1750	620	242.5	601	2100	653	276.5	702
250	10"	1750	672	242.5	601	1750	672	242.5	601	2100	705	276.5	702	2500	775	356	738
300	12"	2100	747	276.5	702	2500	817	356	738	4000	868	415	940	4000	868	415	940
350	14"	2100	774	276.5	702	4000	895	415	940	4000	895	415	940	-	-	-	-
400	16"	4000	924	415	940	400	924	415	940	-	-	-	-	-	-	-	-

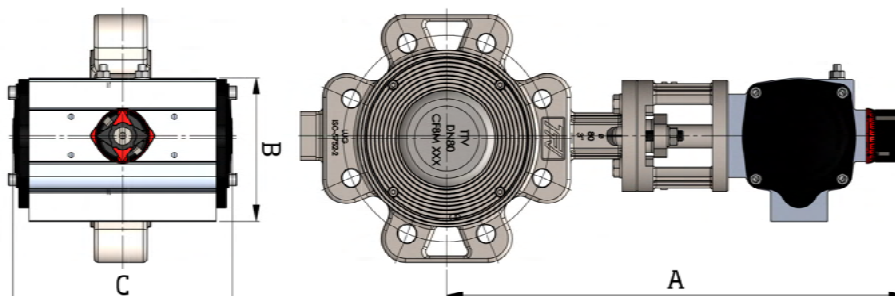

Colossus with Double Effect Actuator (ADA)

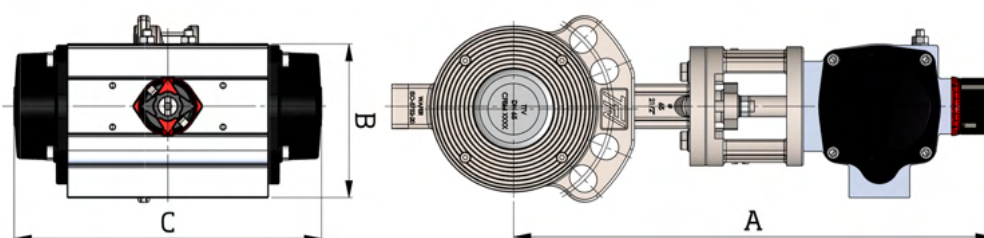

Colossus with Simple Effect Actuator (ASR)

10. COLOSSUS DOUBLE ECCENTRIC VALVE ACTUATING TORQUE

<i>SOFT SEAT (N·m)</i>					
<i>mm</i>	<i>Inch</i>	PN10	PN16	PN20	PN25
40	1 ½"	8	11	14	19
50	2"	12	17	20	25
65	2 ½"	20	25	27	30
80	3"	31	40	42	55
100	4"	45	58	68	75
125	5"	52	65	80	105
150	6"	110	135	160	190
200	8"	150	226	275	314
250	10"	206	304	402	471
300	12"	314	471	588	726
350	14"	502	795	888	980
400	16"	625	985	1071	1157
450	18"	950	1190	1272	1354
500	20"	1297	1725	1938	2150
600	24"	1561	2280	2501	2721

<i>METAL SEAT (N·m)</i>					
<i>mm</i>	<i>Inch</i>	PN10	PN16	PN20	PN25
40	1 ½"	10	14	18	23
50	2"	18	19	25	33
65	2 ½"	25	30	44	50
80	3"	40	50	63	75
100	4"	48	60	72	85
125	5"	85	110	215	320
150	6"	187	229	385	540
200	8"	300	452	601	750
250	10"	412	608	769	930
300	12"	785	1175	1463	1750
350	14"	885	1370	1640	1910
400	16"	1320	1530	1818	2105
450	18"	1505	1880	2385	2890
500	20"	1890	2375	2933	3490
600	24"	2180	2910	4505	6100

<i>FIRE SAFE SEAT (N·m)</i>					
<i>mm</i>	<i>Inch</i>	PN10	PN16	PN20	PN25
40	1 ½"	9	12	15	20
50	2"	14	20	23	29
65	2 ½"	17	29	31	35
80	3"	36	46	48	63
100	4"	52	67	78	86
125	5"	60	75	92	121
150	6"	127	155	184	219
200	8"	173	260	316	361
250	10"	237	350	462	542
300	12"	361	542	676	835
350	14"	577	914	852	1127
400	16"	719	1133	1025	1331
450	18"	1093	1369	1325	1557
500	20"	1492	1984	1983	2473
600	24"	1795	2622	2462	3129

The torques for the superior diametres are available on-demand.

The torques are valid for the actuator election. In case of regulation service, the torques should be incremented in 15%. Safety factor 30%. Valid for water at environment temperature.

The torques described here are just an orientation. They are tested on work pressure and constant conditions. It is recommended to pay attention to the liquid speed due to the dynamic effort of the flow over the disc.

11. FLOW COEFFICIENT (CV)

The valve CV gives a capacity index that allows an easy estimation of the required restriction size to control the liquid flow of any piping system.

The sizing range use for Colossus High Performance flanged valve is between 20° and 70° of opening.

$$\text{Liquids} \rightarrow C_v = 1,72 \cdot Q \cdot \sqrt{\frac{G}{\Delta P}}$$

$$\text{Gas} \rightarrow \text{If } \Delta P < \frac{P_1}{2}; C_v = \frac{Q}{272} \cdot \sqrt{\frac{G(273+T)}{\Delta P(P_1+P_2)}} \quad \text{If } \Delta P \geq \frac{P_1}{2}; C_v = \frac{\sqrt{G(273+T)}}{236 P_1}$$

$$\text{Steam} \rightarrow \text{Si } \Delta P < \frac{P_1}{2}; C_v = \frac{WK}{13,5 \cdot \sqrt{\Delta P \cdot (P_1 + P_2)}} \quad \text{If } \Delta P < \frac{P_1}{2}; C_v = \frac{WK}{11,9 \cdot P_1}$$

Q Fluid flow (liquid m³/h, gas Nm³/h)

W Fluid flow (steam Kg/h)

P₁ Inlet pressure (Liquid Kg/cm², gas and steam Kg/cm² abs.)

P₂ Outlet pressure (Líquido Kg/cm², gas and steam Kg/cm² abs.)

ΔP Pressure drop P₁ - P₂

G Specific gravity of the fluid

T Fluid temperature (C°)

K Steam superheat correction coefficient, 1+0.0013 × deg C° of superheat

Note: When $P_2 < \frac{P_1}{2}$ use $\frac{P_1}{2}$ instead of ΔP

11.1. Characteristic curve

DN		20°	30°	40°	50°	60°	70°	80°	90°
40	1 ½"	14	20	28	37	42	53	76	75
50	2"	19	27	35	43	54	65	76	87
65	2 ½"	17	26	34	43	62	82	101	121
80	3"	40	56	72	88	118	149	179	210
100	4"	40	88	137	186	243	300	355	413
125	5"	54	160	266	372	457	542	626	710
150	6"	71	227	363	499	634	770	906	1042
200	8"	179	432	686	939	1177	1426	1655	1892
250	10"	320	674	1027	1380	1841	2301	2762	3223
300	12"	358	914	1470	2027	2738	3449	4162	4873
350	14"	487	990	1530	2150	2930	3673	4322	5725
400	16"	634	1132	1701	2400	3090	3961	5121	7243
450	18"	596	1373	1915	2731	3313	4632	6534	9863
500	20"	1150	1694	2528	3125	4285	7245	9924	12234
600	24"	1951	3073	4957	6758	9875	12875	16245	20436

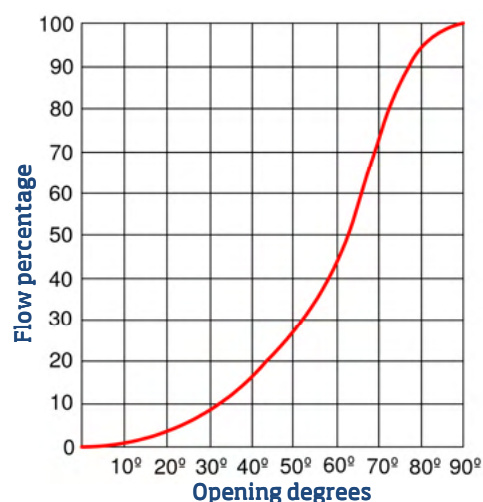

12. CAVITATION

Cavitation occurs when a liquid flows at high speed through a region producing a decompression of the fluid generally caused by a local pressure drop below the fluid steam pressure.

This phenomenon can create an accelerated wear and valves and piping deterioration, as well as noise and vibration problems.

The following formulas can be used to avoid cavitation:

$$\xi = 1,57 \cdot 10^{-3} \cdot \frac{DN^4}{KV^2}$$

$$z = 0,1 \cdot \log \xi + 0,14$$

$$X_f = \frac{\Delta P}{P_1 - P_v}$$

$$X_f < Z_y$$

ξ	Valve restriction factor	Z _y	Cavitation value
X _f	Pressure ratio	ΔP	Pressure drop P ₁ - P ₂
P ₁	Inlet pressure	P _v	Liquid steam pressure
DN	Diameter	K _v	Flow coefficient Kv

13. INSTALLATION

The Colossus valves can work bidirectionally. However they have to be installed in the preferred direction recommended by the manufacturer, taking into account that if the pressure falls upon the valve shaft face, the tightness is at their maximum, and if the pressure falls upon the opposite face, the opening torque is minimized and the seat wear is reduced. Depending in the working conditions and the closing, the appropriate installation will be chosen for each case.

The valve should be installed in that way the pipe pressure is not transmitted to the valve body. Despite the solid structure, such pressures can affect the valve operations. If the pipe pressure is too high, it should be softened with expanding gaskets or compensators. If supports for the valve are needed, they should only support the valve weight and not the pipe anchor points.

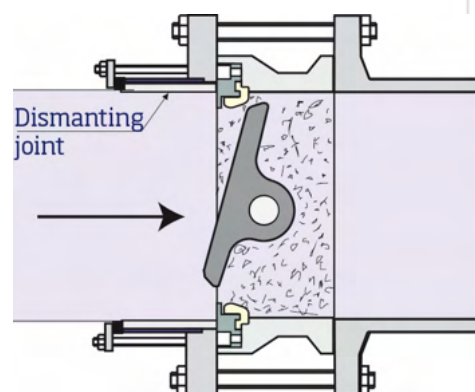

13.1. Installation steps

- All valves should be in total closing position during their installation and removal. It is not needed to apply any force to the seat, but the disc movement has to be restricted to avoid damages.
- Please, make sure there is not any unknown substance and clean the interior part of the pipe and valve.
- The side where the shaft and disc match is considered the high pressure side in the valve (as indicated in the plan with arrows). That means that the highest closing is got at this side of the valve and it has to be noted when assembling. This cannot match with the normal preferred flow. (Picture 3)
- Please, install the shaft horizontal (Picture 3), to avoid the valve to be damaged by sand and other accumulated wastes in the low bushing and seat.

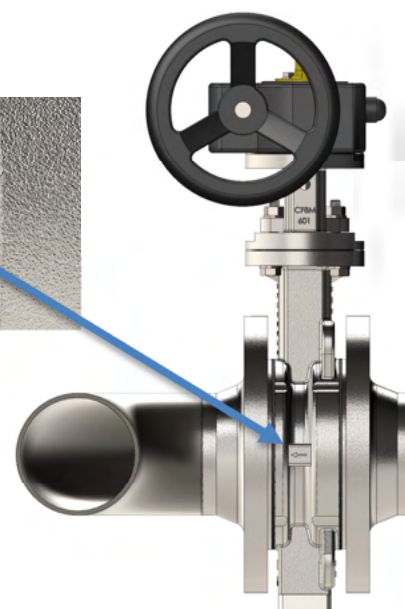
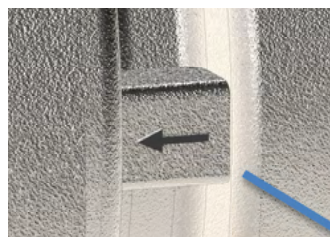

(Picture 3)

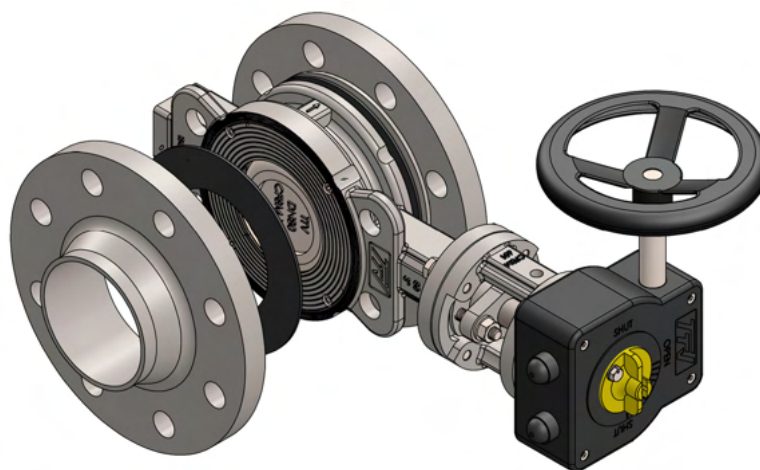

(Picture 4)

- Install the valve and torques in the pipe (Picture 5)

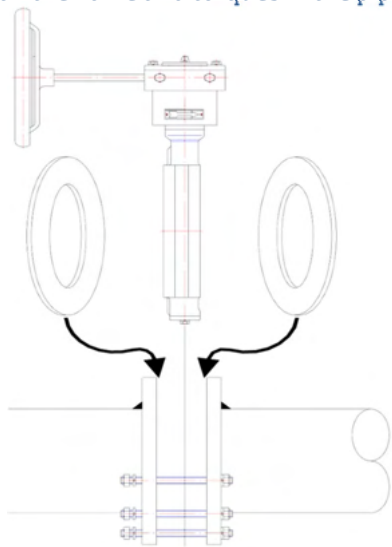

(Picture 5)

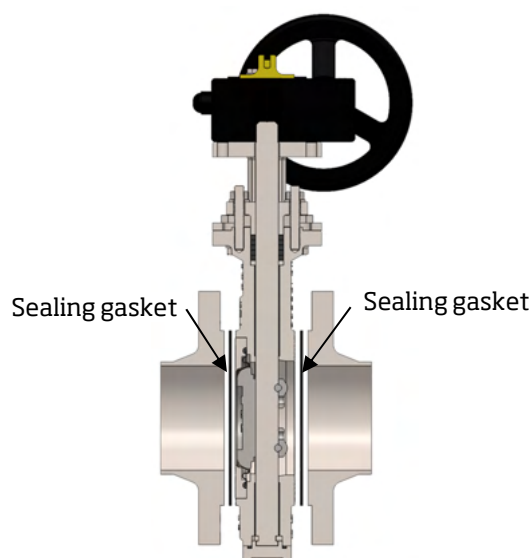

(Picture 6)

- Make sure the valve is concentric installed between the flanges to avoid the disc get damaged by the blockage with the flange and pipe. (Picture 6)
- For the flanged valve installation connected in elbow pipe, the shaft has to be lined up to allow the same flow in both sides of the shaft, minimizing the dynamic strength requirements for the valve. (Picture 7)

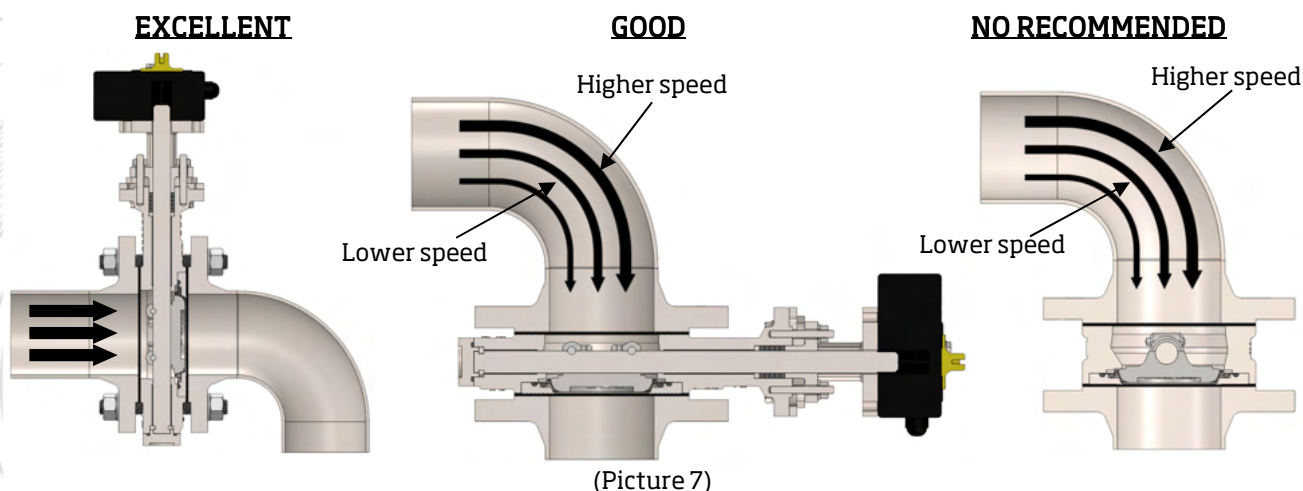

(Picture 7)

- An extension should be used to link the retention valve water type and the flanged one, they should not be directly connected. (Picture 8)

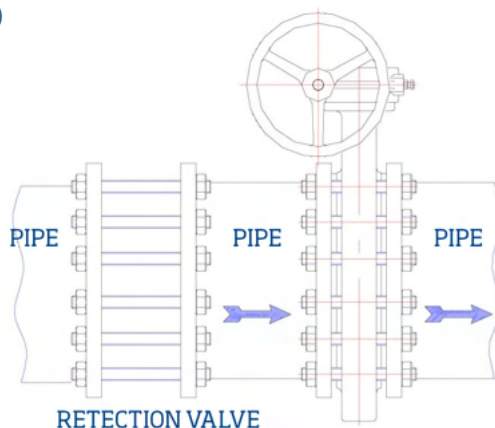

(Picture 8)

14. CONNECTION, FLANGE AND SCREWS

- Keep the flange protected until its installation.
- Make sure the material and gaskets' size are the correct one for the service and check the flanges' and valves' surfaces are clean and flat. Sand the surfaces if there is any impurity.
- Check all screws and nuts are serviceable.
- Apply lubricant as Molidbeno to all screws and nuts before being fixed.
- The pipe supports may require to be partially separated. At first, it should be checked the alignment of the pipe with flange and the space between the flange and the valve. The optimal space would be that that allows the installation of the gasket and where the flange screws' holes are concentric.
- The opposite pipe flange cannot be farther that $\frac{1}{4}$ inch from the other valve face. It could be required to use other alternative methods of alignment to do this requirement.
- Install all the washers keeping a consistent leap between them and the corresponding screws' holes.
- Fasten four alternate screws no more than $\frac{1}{4}$ of a turn by screw until the flanges are held. During this operation, it is recommended to constantly check the distance between flanges. Fasten the screws to the 25% approx. from the final torque of the valve. (See table 1).
- Check the remaining screws and make sure of their correct alignment. Fasten them to the same level as the first screws.
- End fastening the screws of all the flange with a minimum of four increments to the determined torque for the valve.
- Test the valve to check it is not blocked.
- Maximum torque for the flange's screws.

SCREW SIZE	Torque (Nm)
5/8" (M16)	150
3/4" (M20)	270
7/8" (M22)	434
1" (M26)	650
1 1/8" (M28)	815
1 1/4" (M32)	1140

(Table 1)

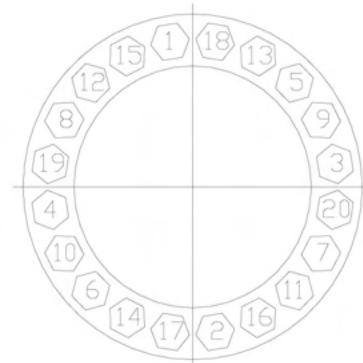

FASTENING SCREWS SEQUENCE(Picture 9)

*The real torque depends on the gasket type. Please consult the gasket manufacturer.

15. MAINTENANCE

15.1. Lubrication

It is recommended to inspect the valves every three months to determine whether its lubrication or other type of maintenance is necessary to the service provided by the valve.

15.2. Packing

The rutinary maintenance of the packing is to fasten the packing regularly. If a leakage is seen around the packing, first fasten the hexagonal nuts from the gland bushing no more than the 2/3 of the compression, because it can reduce the service life of the packing. If the leakage remains, replace the packing following the procedure. (For more clarity, the actuator and the support are not shown in the following pictures. It is not necessary to take out the actuator nor the support to do the following procedure.)

- To be able to have access to the packing, take the gland bushing out and slide up. See the following picture:

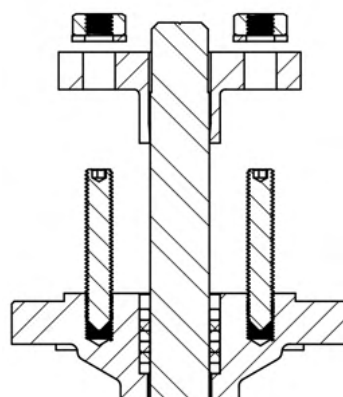

(Picture 10)

- Take all pieces out from the box using a flexible threaded hook. For the boxes with a ring, use a threaded retainer to do it. The ring can be reused, but the rest are not needed. Please, replace the packing, it is not important it is PTFE. (Picture 11)

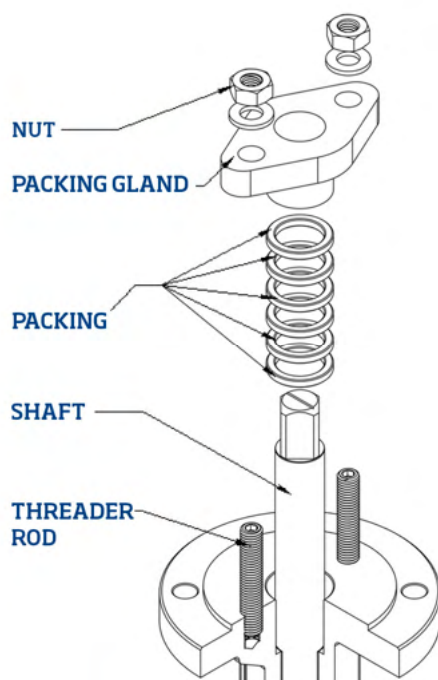

(Picture 11)

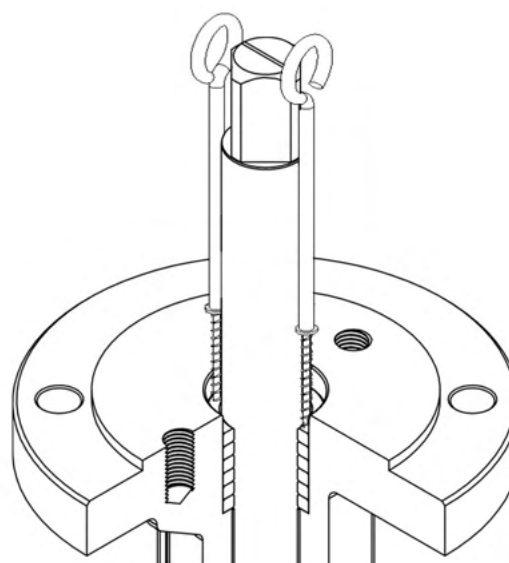

(Picture 12)

- Review the shaft, the packing vacuum and the packing gland bushing. None of the surfaces should have any scratch (Picture 13). In case of any damage, the surface can be polished.

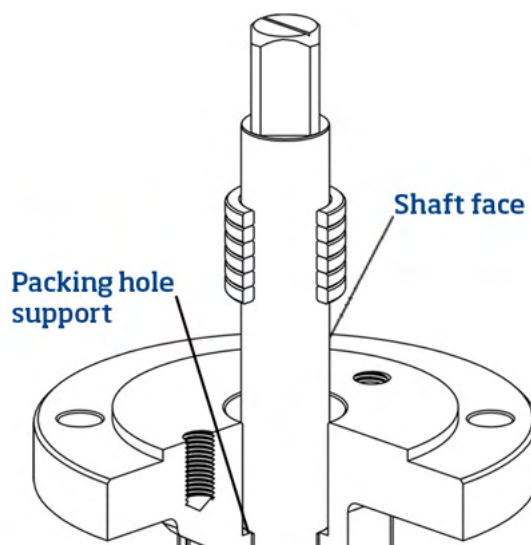

(Picture 13)

- Place again all the rings using the gland bushing to evenly put them in position. Move the gaskets of all the rings so they are as far as possible from each other. (See example.) Turn each ring so the gasket is at 90° from the previous one and the cuts don't meet. (Picture 14)



GRAPHITE PACKING

(Picture 14)

- Install the packing gland bushing and firmly fix the gland to the packing. Do not press the gland bushing much. A higher press exposure may reduce the packing service life and make the valve malfunction. The maximum packing torque is as follows:

Graphite packing		
Screw size	Maximum torque	
M8	2.4	Nm
M10	2.7	Nm
M12	3.6	Nm
M16	5.5	Nm
M20	9.6	Nm

PTFE packing		
Screw size	Maximum torque	
M8	1.45	Nm
M10	1.80	Nm
M12	2.40	Nm
M16	3	Nm
M20	3.85	Nm

Important: If the new packing was PTFE V type, please follow the next instructions:

In case of leakage pressure, please follow picture 15, and in case of pipe vacuum, please follow picture 16.

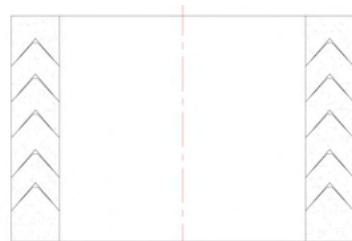

(Picture 15)

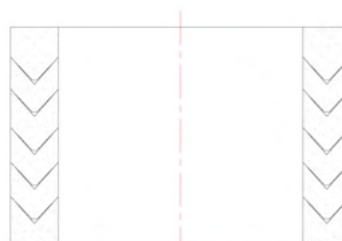

(Picture 16)

16. VALVE UNINSTALLING, ASSEMBLY AND DISASSEMBLY.

16.1. VALVE UNINSTALLING

Please, follow the next instructions to desinstall the valve:

- Make sure the valve is in its closing position and there is not pressure in the pipe.
- Make sure to use suitable clothes and equipment to avoid injures.
- If the valve is attached to an actuator with fail-open system, manually close the valve and disconnect the actuator, and then close the valve before taking it out.
- Attach nylon belts around the valve and the actuator body, take out the screws connecting the valve to the pipe.

16.2. Disassembly

- Place the valve on a bench or any other working surface, with the valve shaft facing up. Retire the actuator and the actuator support from the valve. (Picture 21)

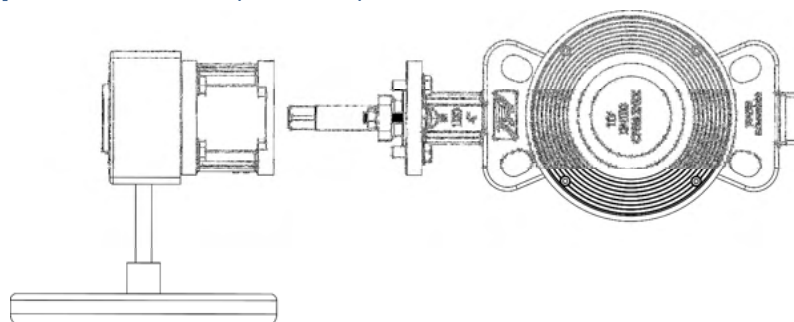

(Picture 21)

- Separate the gland bushing from the packing taking out the hexagonal nuts from the bolts and the take them out.
- Take the packing out using a flexible threaded hook.
- Take the gland bushing out, paying attention to not damage its interior or the shaft's one.
- Open the disc 90°, after separate the retainer from the seat (Picture 22) and seat (Picture 23) from the body.

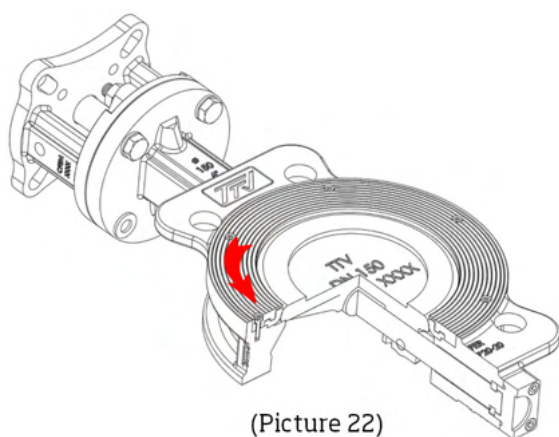

(Picture 22)

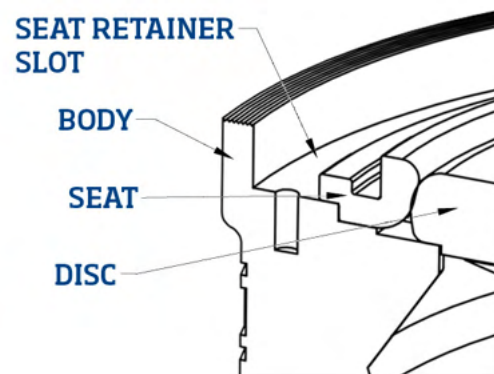

(Picture 23)

16.3. Assembly

- Clean all the valve pieces from oil, grease and dust.
- Review none of the pieces is damaged before the assembly. Carefully examine the shaft extreme and the body and seat surfaces.
- Make sure the valve disc is in total closing position. If not, use the actuator to make the disc move to the total closing position.
- Insert the seat in its assembly slot. The seat will be in a way suspended because it interferes with the disc (Picture 17).

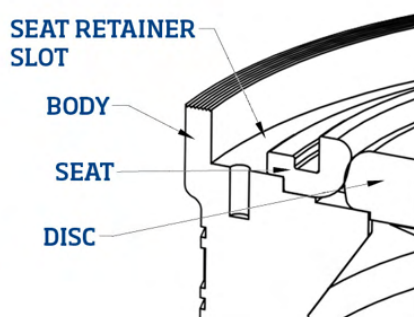

(Picture 17)

- Insert the seat retainer in its assembly slot. The seat and the retainer will be in a way suspended. (Picture 18)

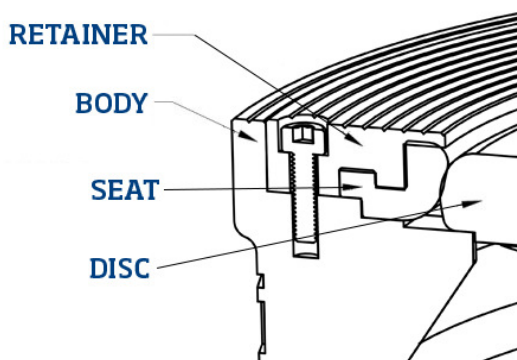

(Picture 18)

- Standard design tighten retainer bolts and in threaded design, turn and tighten in a clockwise direction.
- With our new design, it is normal to have a hole of less than 1mm between the valve face and the retainer when the retainer is fastened (Picture 19 and Picture 20)

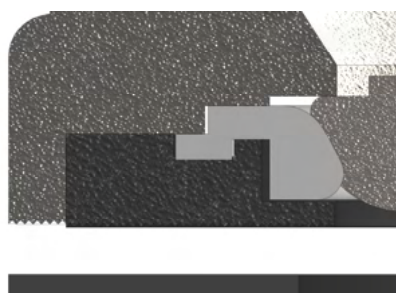

(Picture 19)

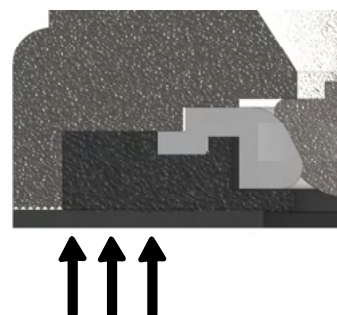

(Picture 20)

- Slightly open the valve 10° and then fasten again the retainer ring.
- Use the actuator again to move the disc to the total closing position before assembling the pipe.
- Insert the rings in their threaded holes in the packing side.
- Place the paking bushing and fasten it with the hexagonal nuts.
- Place the bottom cap with the gasket and fasten it in its position with hexagonal head screws.
- The valve is now ready to attach the actuator. When the disc is secured in its position, the actuator can be placed over the shaft. Please, read the own actuator instructions for more information.

17. SPARE PARTS

VALVES WITH PTFE / RPTFE SEAT

N°	Name	Materials	Quantity
4	Seat	PTFE PTFE + 25% F. Glass	1
7	Guide bushing	Inox + PTFE + Graphite Inox + PTFE	2
9	Packing	PTFE	1
16	Bottom gasket cap	PTFE	1
21	Guide bracket bushing	Inox + PTFE + Graphite	1



VALVES WITH RPTFE SEAT + SS316

N°	Name	Materials	Quantity
4	Soft seat	PTFE + 25% F. Glass	1
4a	Flexible seat	F 316L	1
6	Retainer gasket	Graphite	1
7	Guide bushing	Inox + PTFE + Graphite	2
9	Packing	Graphite	1
16	Bottom gasket cap	Graphite	1
21	Guide bracket bushing	Inox + PTFE + Graphite	1



VALVES WITH METAL SEAT

N°	Name	Materials	Quantity
4	Seat	Inconel	1
6	Retainer gasket	Graphite	1
7	Guide bushing	Inox + PTFE + Graphite	2
9	Packing	Graphite	1
16	Bottom gasket cap	Graphite	1
21	Guide bracket bushing	Inox + PTFE + Graphite	1



- The spare parts sets are normally available.

18. PRESSURE | TEMPERATURE

Study and simulation of the evolution of the mechanic properties of the material subjected to high temperature warming or low temperature cooling.

The graphics show temperature and pressure ranges according to the disc manufacture materials and the seat manufacture valve.

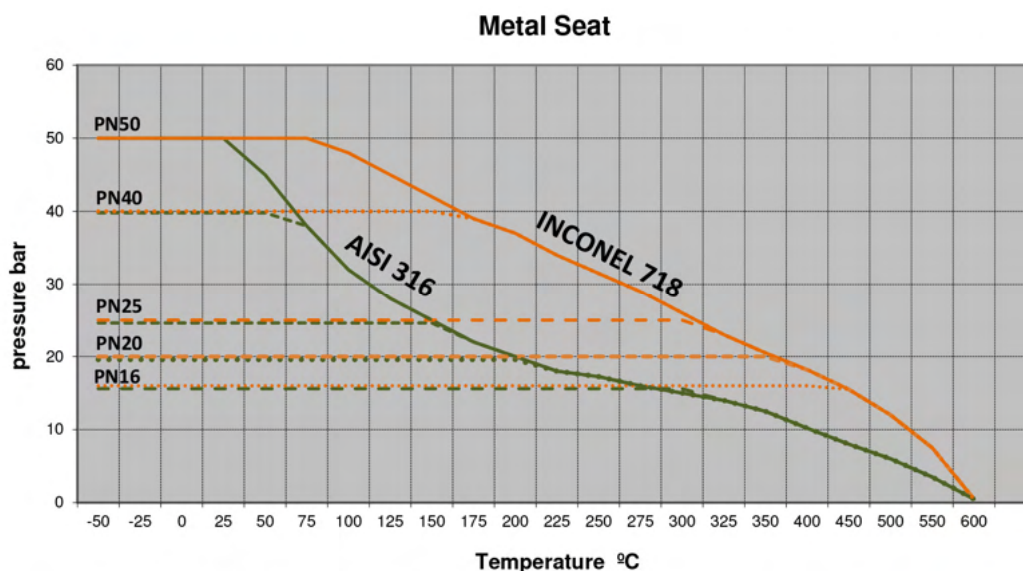
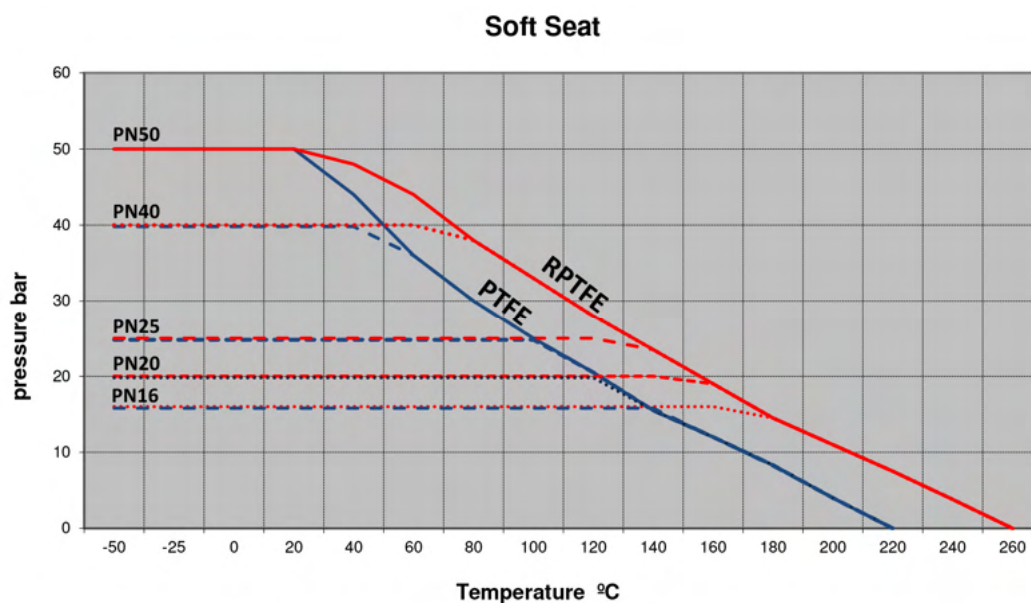

19. FLUID SIMULATION

3D simulation of the fluid to develop an aerodynamic disc with less noise and turbulence in the Colossus valve.

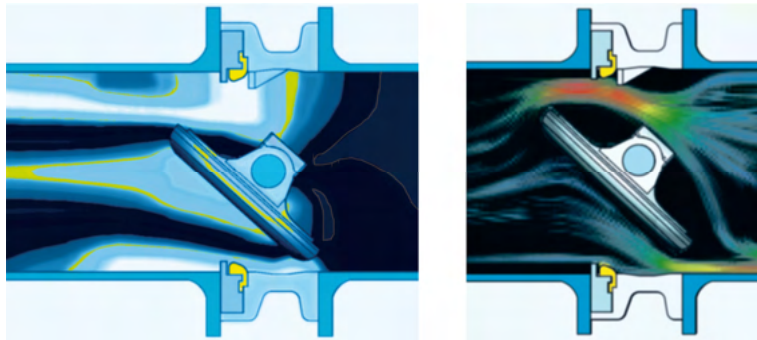

20. MATERIAL RESISTANCE STUDY SUBJECTED TO PRESSURE

Performance and stress analysis according to ISO-5208 / API598

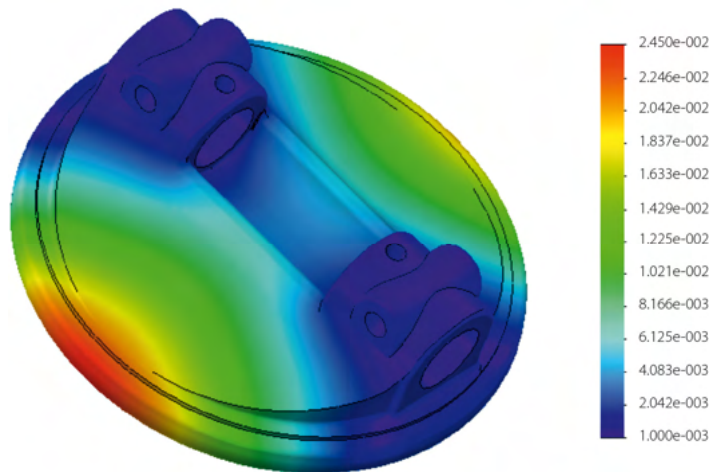

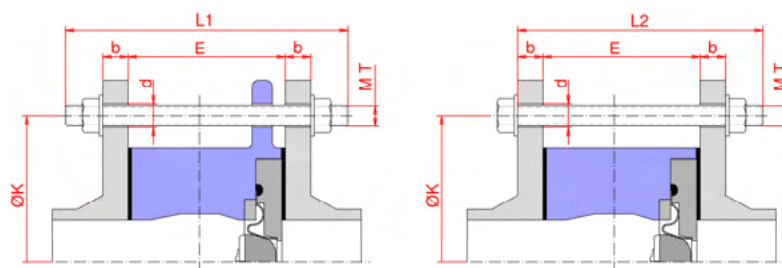
21. WAFER SCREWS | PN10 - PN25

PN10

VALVE		FLANGE				SCREWS			THREADED RODS		
DN	E	b	ØK	N°	d	Scr. N°	MT1	L2	Scr. N°	MT1	L1
40	33	16	110	4	18	4	M16	100	4	M16	130
50	43	18	125	4	18	4	M16	120	4	M16	150
65	46,5	18	145	4	18	4	M16	120	4	M16	150
80	47	20	160	8	18	8	M16	130	8	M16	150
100	52	20	180	8	18	8	M16	130	8	M16	160
125	56	22	210	8	18	8	M16	140	8	M16	170
150	56	22	240	8	23	8	M20	140	8	M20	170
200	63	24	295	8	23	8	M20	150	8	M20	180
250	71	26	350	12	23	12	M20	170	12	M20	200
300	78	26	400	12	23	12	M20	170	12	M20	200
350	78	26	460	16	23	16	M20	170	16	M20	200
400	102	26	515	16	27	16	M24	200	16	M24	230
450	114	28	565	20	27	20	M24	220	20	M24	250
500	127	28	620	20	27	20	M24	230	20	M24	260
600	154	28	725	20	30	20	M27	260	20	M27	300

PN16

VALVE		FLANGE				SCREWS			THREADED RODS		
DN	E	b	ØK	N°	d	Scr. N°	MT1	L2	Scr. N°	MT1	L1
40	33	16	110	4	18	4	M16	100	4	M16	130
50	43	18	125	4	18	4	M16	120	4	M16	150
65	46,5	18	145	4	18	4	M16	120	4	M16	150
80	47	20	160	8	18	8	M16	130	8	M16	150
100	52	20	180	8	18	8	M16	130	8	M16	160
125	56	22	210	8	18	8	M16	140	8	M16	170
150	56	22	240	8	23	8	M20	140	8	M20	170
200	63	24	295	12	23	12	M20	150	12	M20	180
250	71	26	355	12	27	12	M24	170	12	M24	200
300	78	28	410	12	27	12	M24	180	12	M24	210
350	78	30	470	16	27	16	M24	180	16	M24	220
400	102	32	525	16	30	16	M27	210	16	M27	250
450	114	32	585	20	30	20	M27	230	20	M27	260
500	127	34	650	20	33	20	M30	250	20	M30	280
600	154	36	770	20	36	20	M33	280	20	M33	320

PN25

VALVE		FLANGE				SCREWS			THREADED RODS		
DN	E	b	ØK	N°	d	Scr. N°	MT1	L2	Scr. N°	MT1	L1
40	33	18	110	4	18	4	M16	110	4	M16	140
50	43	20	125	4	18	4	M16	120	4	M16	150
65	46,5	22	145	8	18	8	M16	130	8	M16	160
80	47	24	160	8	18	8	M16	130	8	M16	160
100	52	24	190	8	23	8	M20	140	8	M20	170
125	56	26	220	8	27	8	M24	150	8	M24	190
150	56	28	250	8	27	8	M24	160	8	M24	190
200	63	30	310	12	27	12	M24	170	12	M24	200
250	71	32	370	12	30	12	M27	180	12	M27	220
300	78	34	430	16	30	16	M27	190	16	M27	230
350	78	38	490	16	33	16	M30	200	16	M30	240
400	102	40	550	16	36	16	M33	230	16	M33	280
500	127	44	660	20	36	20	M33	270	20	M33	310
600	154	46	770	20	39	20	M36	300	20	M36	350

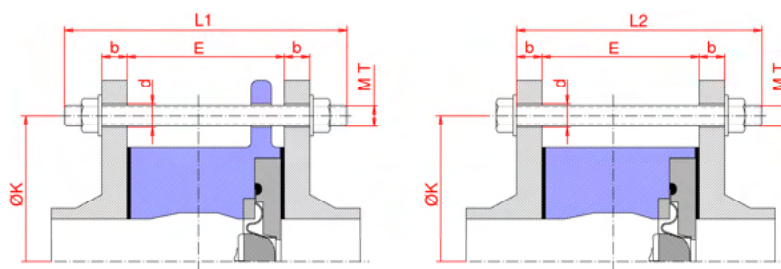
22. WAFER SCREWS | ANSI150 - ANSI300

ANSI150

VALVE		FLANGE				SCREWS				THREADED RODS			
DN	E	b	ØK	N°	d	Scr.N°	MT1	Step	L2	Scr.N°	MT1	Step	L1
40	33	17,5	98,4	4	15,9	4	1/2"	12	110	4	1/2"	12	130
50	43	19	125	4	19	4	5/8"	11	120	4	5/8"	11	150
65	46,5	22,2	139,7	4	19	4	5/8"	11	130	4	5/8"	11	160
80	47	23,8	152,4	8	19	4	5/8"	11	140	4	5/8"	11	170
100	52	23,8	190,5	8	19	8	5/8"	11	140	8	5/8"	11	170
125	56	23,8	215,9	8	22,2	8	3/4"	10	150	8	3/4"	10	180
150	56	25,4	241,3	8	22,2	8	3/4"	10	150	8	3/4"	10	190
200	63	28,6	298,4	8	22,2	8	3/4"	10	170	8	3/4"	10	200
250	71	30,2	361,9	12	25,4	12	7/8"	9	180	12	7/8"	9	220
300	78	31,7	431,8	12	25,4	12	7/8"	9	190	12	7/8"	9	230
350	78	34,9	476,2	16	28,6	12	1"	8	200	12	1"	8	240
400	102	36,5	539,7	16	28,6	16	1"	8	230	16	1"	8	270
450	114	39,7	577,8	20	31,7	16	1 1/8"	7	250	16	1 1/8"	7	290
500	127	42,9	635	20	31,7	20	1 1/8"	7	270	20	1 1/8"	7	310
600	154	47,6	749,3	20	34,9	20	1 1/4"	7	310	20	1 1/4"	7	350

ANSI300

VALVE		FLANGE				SCREWS				THREADED RODS			
DN	E	b	ØK	N°	d	Scr.N°	MT1	Step	L2	Scr.N°	MT1	Step	L1
40	33	20,6	114,3	4	22,2	4	3/4"	10	120	4	3/4"	10	150
50	43	22,2	127	8	19	8	5/8"	11	130	8	5/8"	11	160
65	46,5	25,4	149,2	8	22,2	8	3/4"	10	140	8	3/4"	10	180
80	47	28,6	168,3	8	22,2	8	3/4"	10	150	8	3/4"	10	180
100	52	31	200	8	22,2	8	3/4"	10	160	8	3/4"	10	190
125	56	34,9	234,9	8	22,2	8	3/4"	10	170	8	3/4"	10	210
150	56	36,5	269,9	12	22,2	12	3/4"	10	170	12	3/4"	10	210
200	63	41,3	330,2	12	25,4	12	7/8"	9	190	12	7/8"	9	230
250	71	47,6	387,3	16	28,6	16	1"	8	220	16	1"	8	260
300	78	50,8	450,8	16	31,7	16	1 1/8"	7	230	16	1 1/8"	7	280
350	78	54	514,3	20	31,7	20	1 1/8"	7	240	20	1 1/8"	7	280
400	102	57,1	571,5	20	34,9	20	1 1/4"	7	270	20	1 1/4"	7	320
450	114	60,3	628,6	24	34,9	24	1 1/4"	7	290	24	1 1/4"	7	340
500	127	63,5	685,8	24	34,9	24	1 1/4"	7	310	24	1 1/4"	7	360
600	154	69,8	812,8	24	41,3	24	1 1/2"	6	360	24	1 1/2"	6	410

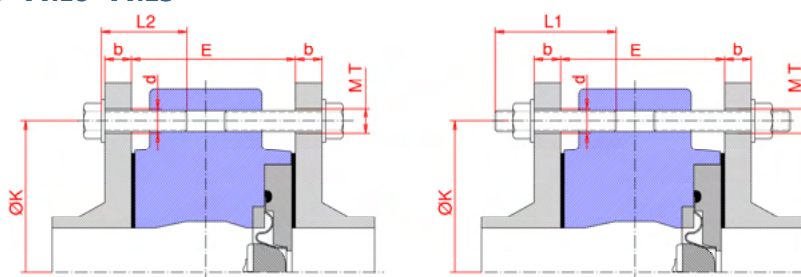
23. LUG SCREWS | PN10 - PN16 - PN25

PN10

VALVE		FLANGE				SCREWS			THREADED RODS		
DN	E	b	ØK	N°	d	Scr. N°	MT1	L2	Scr. N°	MT1	L1
40	33	16	110	4	18	4+4	M16	40	4+4	M16	60
50	43	18	125	4	18	4+4	M16	40	4+4	M16	70
65	46,5	18	145	4	18	4+4	M16	40	4+4	M16	70
80	47	20	160	8	18	8+8	M16	50	8+8	M16	70
100	52	20	180	8	18	8+8	M16	50	8+8	M16	80
125	56	22	210	8	18	8+8	M16	50	8+8	M16	80
150	56	22	240	8	23	8+8	M20	50	8+8	M20	80
200	63	24	295	8	23	8+8	M20	60	8+8	M20	90
250	71	26	350	12	23	12+12	M20	60	12+12	M20	100
300	78	26	400	12	23	12+12	M20	70	12+12	M20	100
350	78	26	460	16	23	16+16	M20	70	16+16	M20	100
400	102	26	515	16	27	16+16	M24	80	16+16	M24	110
450	114	28	565	20	27	20+20	M24	90	20+20	M24	120
500	127	28	620	20	27	20+20	M24	90	20+20	M24	130
600	154	28	725	20	30	20+20	M27	110	20+20	M27	150

PN16

VALVE		FLANGE				SCREWS			THREADED RODS		
DN	E	b	ØK	N°	d	Scr. N°	MT1	L2	Scr. N°	MT1	L1
40	33	16	110	4	18	4+4	M16	40	4+4	M16	60
50	43	18	125	4	18	4+4	M16	40	4+4	M16	70
65	46,5	18	145	4	18	4+4	M16	40	4+4	M16	70
80	47	20	160	8	18	8+8	M16	50	8+8	M16	70
100	52	20	180	8	18	8+8	M16	50	8+8	M16	80
125	56	22	210	8	18	8+8	M16	50	8+8	M16	80
150	56	22	240	8	23	8+8	M20	50	8+8	M20	80
200	63	24	295	12	23	12+12	M20	60	12+12	M20	90
250	71	26	355	12	27	12+12	M24	60	12+12	M24	100
300	78	28	410	12	27	12+12	M24	70	12+12	M24	100
350	78	30	470	16	27	16+16	M24	70	16+16	M24	110
400	102	32	525	16	30	16+16	M27	90	16+16	M27	120
450	114	34	585	20	30	20+20	M27	90	20+20	M27	130
500	127	34	650	20	33	20+20	M30	100	20+20	M30	140
600	154	36	770	20	36	20+20	M33	120	20+20	M33	160

PN25

VALVE		FLANGE				SCREWS			THREADED RODS		
DN	E	b	ØK	N°	d	Scr. N°	MT1	L2	Scr. N°	MT1	L1
40	33	18	110	4	18	4+4	M16	40	4+4	M16	70
50	43	20	125	4	18	4+4	M16	40	4+4	M16	70
65	46,5	22	145	8	18	8+8	M16	50	8+8	M16	80
80	47	24	160	8	18	8+8	M16	50	8+8	M16	80
100	52	24	190	8	23	8+8	M20	50	8+8	M20	80
125	56	26	220	8	27	8+8	M24	60	8+8	M24	90
150	56	28	250	8	27	8+8	M24	60	8+8	M24	90
200	63	30	310	12	27	12+12	M24	60	12+12	M24	100
250	71	32	370	12	30	12+12	M27	70	12+12	M27	110
300	78	34	430	16	30	16+16	M27	80	16+16	M27	110
350	78	38	490	16	33	16+16	M30	80	16+16	M30	120
400	102	40	550	16	36	16+16	M33	90	16+16	M33	140
500	127	44	660	20	36	20+20	M33	110	20+20	M33	150
600	154	46	770	20	39	20+20	M36	130	20+20	M36	170

24. LUG SCREWS | ANSI150 - ANSI300

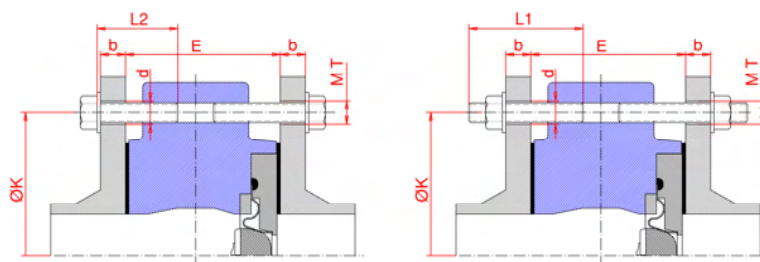

ANSI 150

VALVE		FLANGE				SCREWS				THREADED RODS			
DN	E	b	ØK	N°	d	Scr. N°	MT1	Step	L2	Scr. N°	MT1	Step	L1
40	33	17.5	98.4	4	15.9	4+4	1/2"	12	40	4+4	1/2"	12	70
50	43	19	120.6	4	19	4+4	5/8"	11	40	4+4	5/8"	11	70
65	46,5	22.2	139.7	4	19	4+4	5/8"	11	50	4+4	5/8"	11	80
80	47	23.8	152.4	4	19	4+4	5/8"	11	50	4+4	5/8"	11	80
100	52	23.8	190.5	8	19	8+8	5/8"	11	50	8+8	5/8"	11	80
125	56	23.8	215.9	8	22.2	8+8	3/4"	10	60	8+8	3/4"	10	80
150	56	25.4	241.3	8	22.2	8+8	3/4"	10	60	8+8	3/4"	10	80
200	63	28.6	298.4	8	22.2	8+8	3/4"	10	60	8+8	3/4"	10	90
250	71	30.2	361.9	12	25.4	12+12	7/8"	9	70	12+12	7/8"	9	100
300	78	31.7	431.8	12	25.4	12+12	7/8"	9	70	12+12	7/8"	9	100
350	78	34.9	476.2	12	28.6	12+12	1"	8	80	12+12	1"	8	110
400	102	36.5	539.7	16	28.6	16+16	1"	8	90	16+16	1"	8	120
450	114	39.7	577.8	16	31.7	16+16	1.1/8"	7	100	16+16	1.1/8"	7	130
500	127	42.9	635	20	31.7	20+20	1.1/8"	7	110	20+20	1.1/8"	7	140
600	154	47.6	749.3	20	34.9	20+20	1.1/4"	7	130	20+20	1.1/4"	7	160

ANSI 300

VALVE		FLANGE				SCREWS				THREADED RODS			
DN	E	b	ØK	N°	d	Scr. N°	MT1	Step	L2	Scr. N°	MT1	Step	L1
40	33	20,6	114,3	4	22,2	4+4	3/4"	10	40	4+4	3/4"	10	70
50	43	22,2	127	8	19	8+8	5/8"	11	50	8+8	5/8"	11	80
65	46,5	25,4	149,2	8	22,2	8+8	3/4"	10	50	8+8	3/4"	10	80
80	47	28,6	168,3	8	22,2	8+8	3/4"	10	60	8+8	3/4"	10	80
100	52	31	200	8	22,2	8+8	3/4"	10	60	8+8	3/4"	10	90
125	56	34,9	234,9	8	22,2	8+8	3/4"	10	70	8+8	3/4"	10	90
150	56	36,5	269,9	12	22,2	12+12	3/4"	10	70	12+12	3/4"	10	100
200	63	41,3	330,2	12	25,4	12+12	7/8"	9	80	12+12	7/8"	9	100
250	71	47,6	387,3	16	28,6	16+16	1"	8	90	16+16	1"	8	110
300	78	50,8	450,8	16	31,7	16+16	1 1/8"	7	90	16+16	1 1/8"	7	120
350	78	54	514,3	20	31,7	20+20	1 1/8"	7	100	20+20	1 1/8"	7	120
400	102	57,1	571,5	20	34,9	20+20	1 1/4"	7	110	20+20	1 1/4"	7	140
450	114	60,3	628,6	24	34,9	24+24	1.1/4"	7	120	24+24	1.1/4"	7	150
500	127	63,5	685,8	24	34,9	24+24	1.1/4"	7	130	24+24	1.1/4"	7	160
600	154	69,8	812,8	24	41,3	24+24	1.1/2"	6	150	24+24	1.1/2"	6	180

25. VALVE CODIFICATION

Eg.: 50WX4040I0

Body material		Serie		Valve type		Shaft material		Disc material		Seat material	
50		W		X		40		40		I0	
40	CF-8M	W	Wafer	X	2-eccentric	40	AISI 316	40	CF-8M	F5	PTFE + 25% Fiberglass
50	A216 WCB	L	Lug			9T	AISI 431			I0	Inconel 718
		B	Flanges							F4	RPTFE + AISI 316
		H	Double flange							F0	PTFE

NOTES

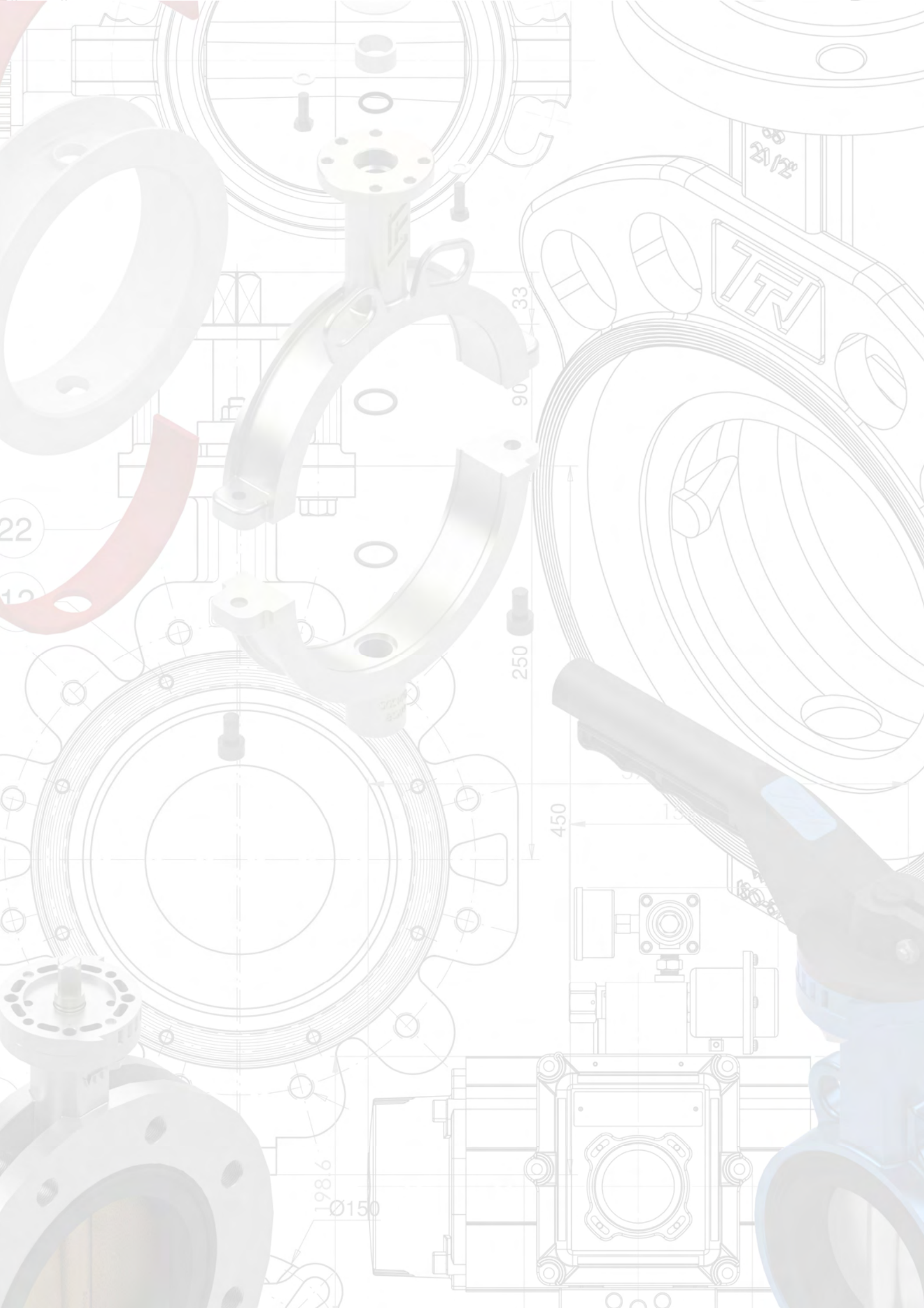

20/22

TRV

22

12

33

90

250

450

198.6
Ø150



Calle de Severo Ochoa, 11
 Polígono Ind. Ntra. Sra. De Butarque
 28914 Leganes (Madrid)

T: +34 916 857 365

F: +34 916 800 660

valves@ttv.es