

MULTI-TURN & QUARTER TURN GEARBOXES

SHORT VERSION

[Click here](#) for complete version of this catalogue

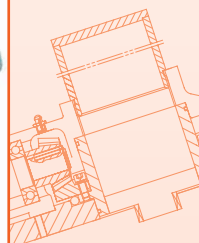
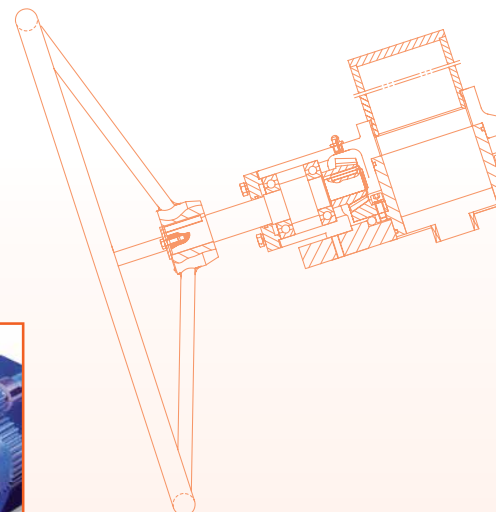

**AUSTRALIAN
PIPELINE VALVE®**

www.australianpipelinevalve.com.au

QUALITY MANUFACTURER

QUALITY COMMITMENT

Quality is Our First Priority.

Consistent product quality and a proven track record makes Australian Pipeline Valve a dependable choice where total reliability is the number one concern.

Since its founding, APV's philosophy has been focused on quality. Our valves are manufactured in full compliance to worldwide standards (such as ASME/ANSI, API, EN, ISO, BS, AS).

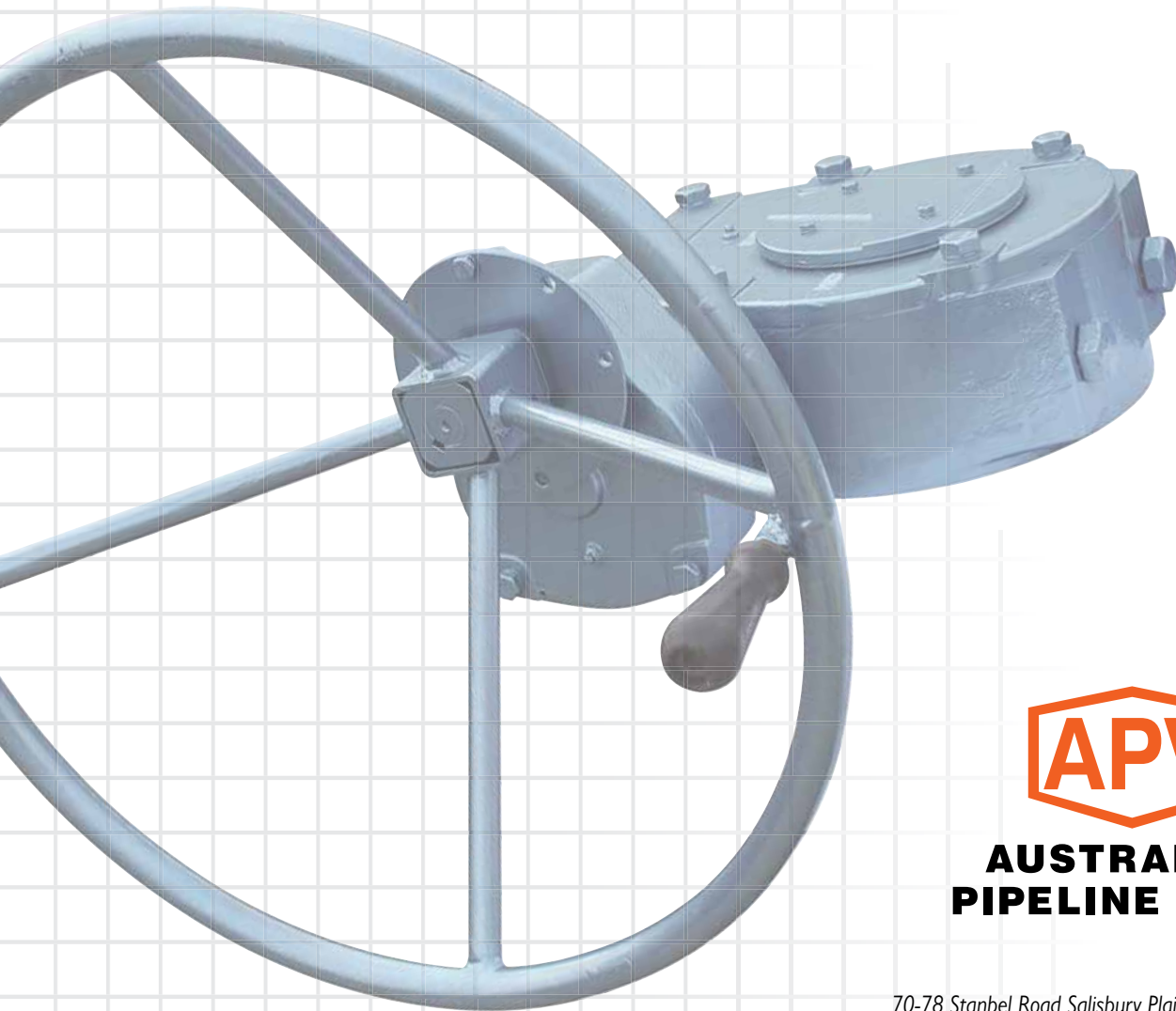

**AUSTRALIAN
PIPELINE VALVE®**

70-78 Stanbel Road Salisbury Plain South Australia 5109

Telephone +61 (0)8 8285 0033

email: admin@australianpipelinevalve.com.au

www.australianpipelinevalve.com.au

CONTENTS - SHORT VERSION*

BA Series Bevel Gear Operator	4
BA-0 Bevel Gear Operator	5
BA-1 Bevel Gear Operator	6
BA-2 Bevel Gear Operator	7
BA-3 Bevel Gear Operator	8
BAA-3 Bevel Gear Operator	9~10*
Worm Gear Operator	11
WG007 Worm Gear Operator	12~13*
WG008 Worm Gear Operator	14~15*
WG108 Worm Gear Operator	16~17*
WG158 Worm Gear Operator	18~19*
WG208 Worm Gear Operator	20~21*
WG238 Worm Gear Operator	22~23*
WG308 Worm Gear Operator	24~25*
WG358 Worm Gear Operator	26~27*
WG408 Worm Gear Operator	28~29*
WG448 Worm Gear Operator	30~31*
WG508 Worm Gear Operator	32~33*
WG608 Worm Gear Operator	34~35*
WG708 Worm Gear Operator	36~37*
SH Series Worm Gear Operator	38*
DC Series Worm Gear Operator	39
MOS Series Declutchable Gear Over-Ride	40~44*

* This version excludes some of these pages, refer to full version at website.



© Copyright Australian Pipeline Valve 1990 - 2023 Edition

Catalogues, photos, brochures and technical publications are the exclusive property of Australian Pipeline Valve. Any unauthorised reproduction in total or in part, shall result in prosecution. Products and data sheets in this publication are subject to change at anytime without notice. Australian Pipeline Valve reserves the right to carry out amendments to products and materials.

BA SERIES BEVEL GEAR OPERATOR

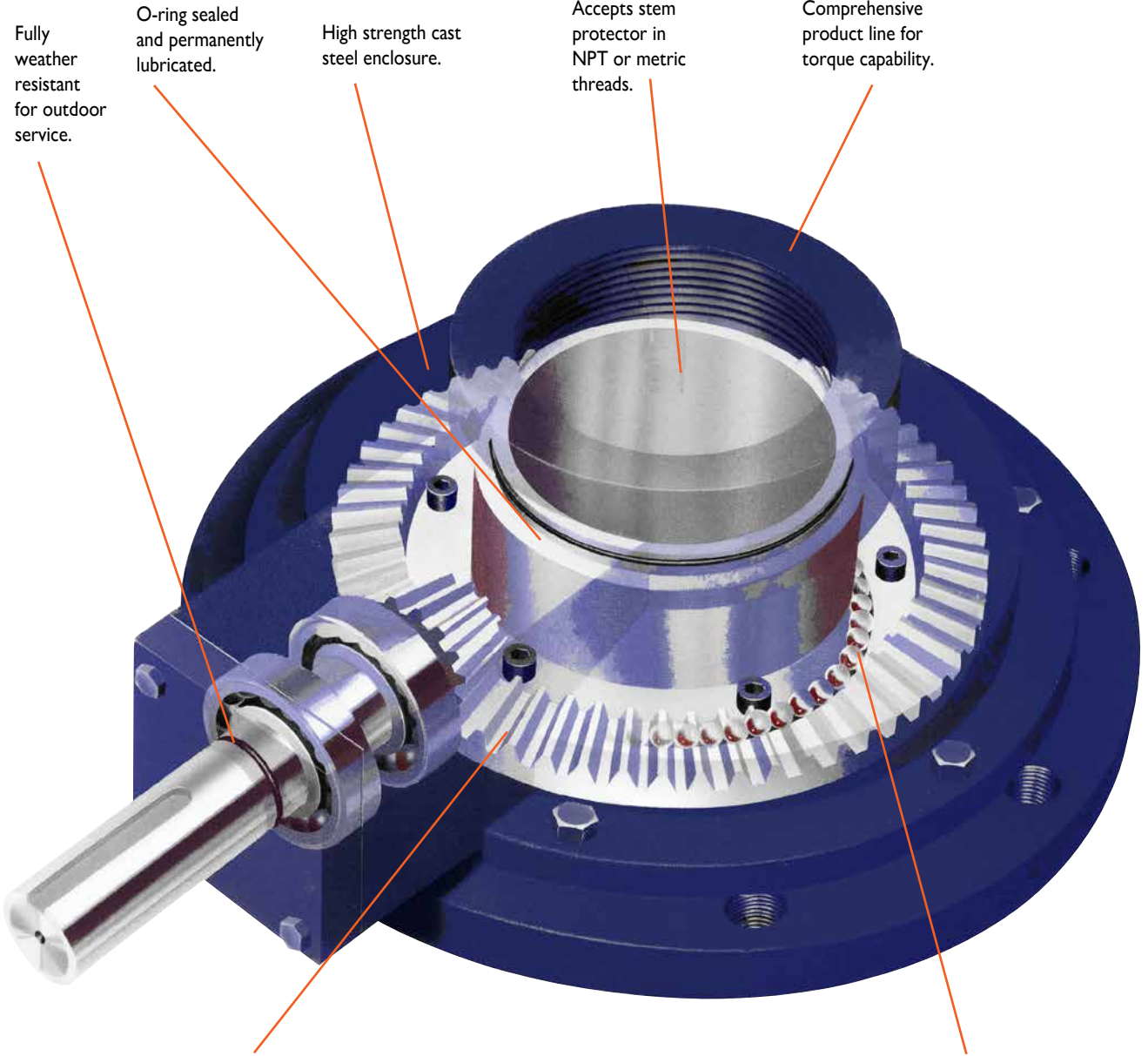

Fully weather resistant for outdoor service.

O-ring sealed and permanently lubricated.

High strength cast steel enclosure.

Accepts stem protector in NPT or metric threads.

Comprehensive product line for torque capability.

Precision machined gearing assures minimum backlash and smooth operation.

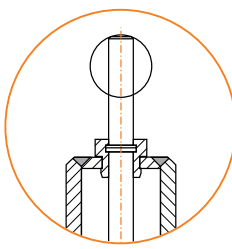
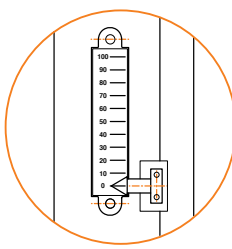

Bevel pinion and bevel gear supported by anti-friction bearings.

Optional open/close indicators

BEVEL GEAR

Rugged, dependable, precision performance for all multi-turn valve applications.



Endurance Test Certified

BA-0 BEVEL GEAR OPERATOR

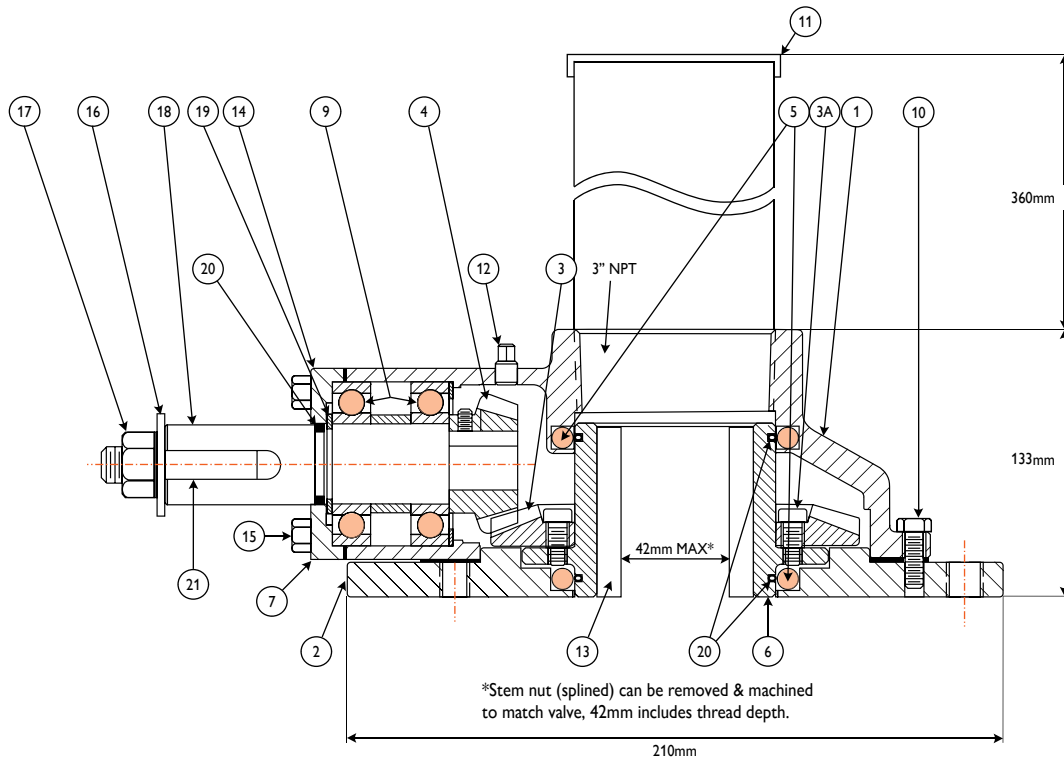

MOUNTING PATTERN

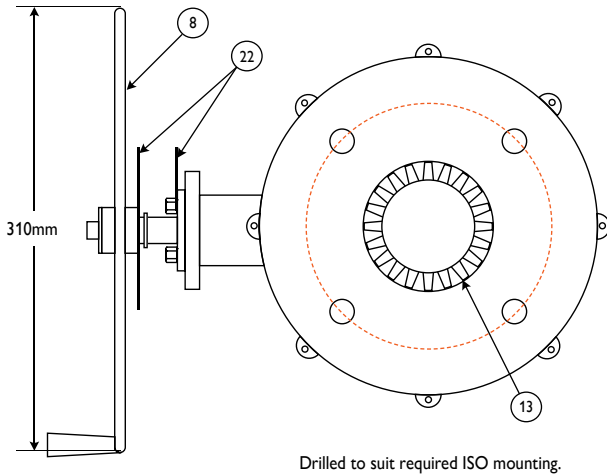

Handwheel & Stem Protector Included

PARTS AND BILL OF MATERIALS

No	Part Name	Qty	Material
1	Housing	1	Carbon Steel
2	Base	1	Carbon Steel
3	Bevel Gear	1	1045 Carbon Steel
3A	Bevel Gear Capscrew	6	Carbon Steel
4	Pinion Gear & Input Shaft	1	1045 Carbon Steel + ENP
5	Bearing Balls	47	GCR15
6	Drive Sleeve	1	Ductile Iron
7	Cover	4	Carbon Steel
8	Handwheel	1	Assembly + FBE
9	Ball Bearing	2	Commercial
10	Bolt	10	Carbon Steel
11	Stem Protector & Cap	1	Steel Pipe - Galvanised
12	Grease Nipple	1	AISI 1020 + ZP
13	Stem Nut Insert	1	Brass H62
14	Cap	1	Carbon Steel
15	Bolt	1	1045 Carbon Steel + ZP
16	Washer	1	Steel + ZP
17	Nut	1	Brass or 2H
18	Pinion Gear Input Shaft	1	1045 + ENP
19	Snap Ring	3	Spring Steel 65 MN
20	O-Ring	2	EPDM
21	Key	1	A3 + ZP
22	Locking Device	1	A3 + ZP + FBE

No couplings or brackets are supplied. The splined stem nut insert (13) in gearbox can be removed and ACME threaded to match valve stem. Alternatively the stem nut from your existing valve can be utilised, a simple coupler then needs to be made to match gear box.

QUICK REFERENCE

Unit Type	Weight in KG W/O Wheel	Output Torque NM	Input Torque NM	Unit Ratio	Maximum Stem Diameter	Maximum Thrust
BA-0	28	735	240	3.6:1	42mm	141KN

BA-1 BEVEL GEAR OPERATOR

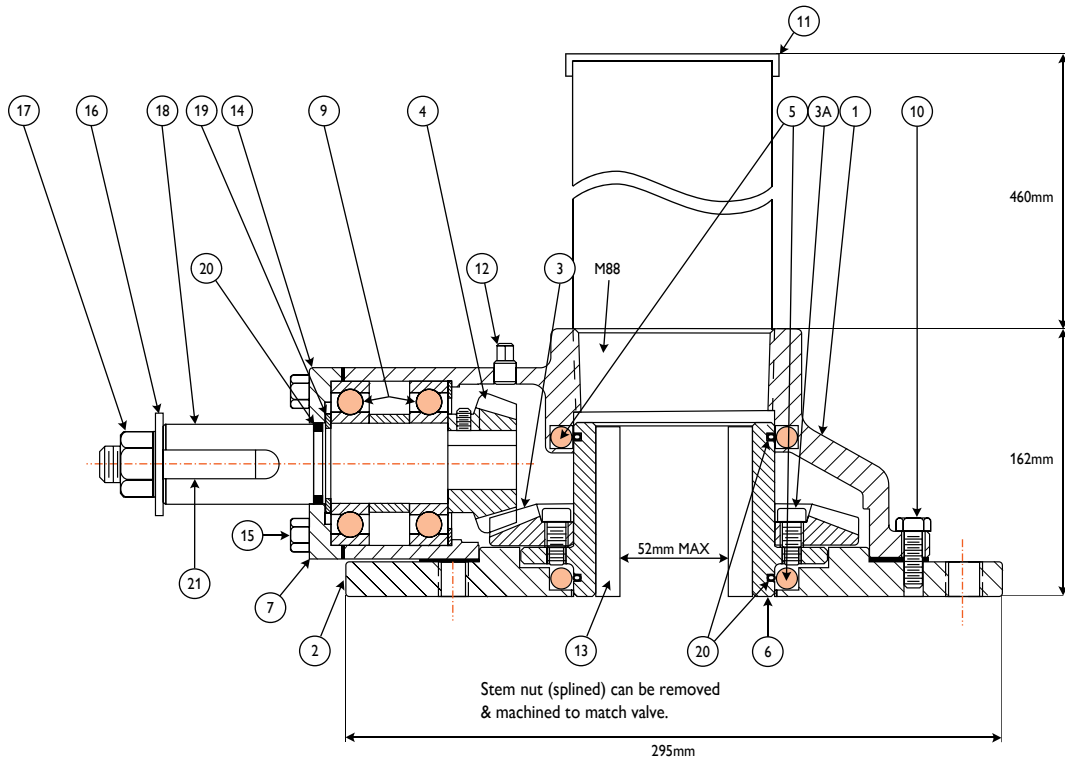

MOUNTING PATTERN

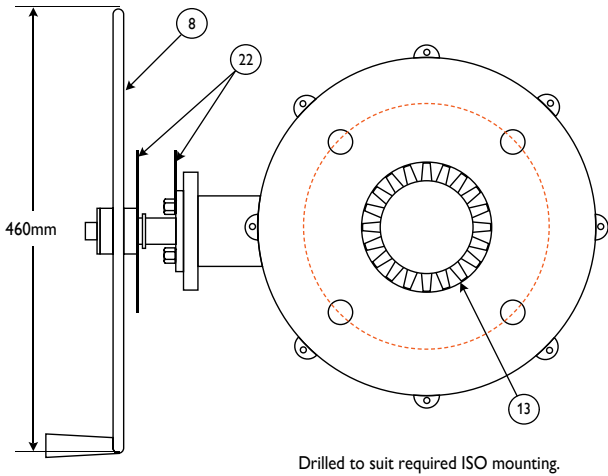

Handwheel & Stem Protector Included

PARTS AND BILL OF MATERIALS

No	Part Name	Qty	Material
1	Housing	1	Carbon Steel
2	Base	1	Carbon Steel
3	Bevel Gear	1	1045 Carbon Steel
3A	Bevel Gear Capscrew	6	Carbon Steel
4	Pinion Gear & Input Shaft	1	1045 Carbon Steel + ENP
5	Bearing Balls	47	GCR15
6	Drive Sleeve	1	Ductile Iron
7	Cover	4	Carbon Steel
8	Handwheel	1	Assembly + FBE
9	Ball Bearing	2	Commercial
10	Bolt	10	Carbon Steel
11	Stem Protector & Cap	1	Steel Pipe - Galvanised
12	Grease Nipple	1	AISI 1020 + ZP
13	Stem Nut Insert	1	Brass H62
14	Cap	1	Carbon Steel
15	Bolt	1	1045 Carbon Steel + ZP
16	Washer	1	Steel + ZP
17	Nut	1	Brass or 2H
18	Pinion Gear Input Shaft	1	1045 + ENP
19	Snap Ring	3	Spring Steel 65 MN
20	O-Ring	2	EPDM
21	Key	1	A3 + ZP
22	Locking Device	1	A3 + ZP + FBE

No couplings or brackets are supplied. The splined stem nut insert (13) in gearbox can be removed and ACME threaded to match valve stem. Alternatively the stem nut from your existing valve can be utilised, a simple coupler then needs to be made to match gear box.

QUICK REFERENCE

Unit Type	Weight in KG W/O Wheel	Output Torque NM	Input Torque NM	Unit Ratio	Maximum Stem Diameter	Maximum Thrust
BA-1	54	1500	400	4.5:1	50mm	190KN

BA-2 BEVEL GEAR OPERATOR

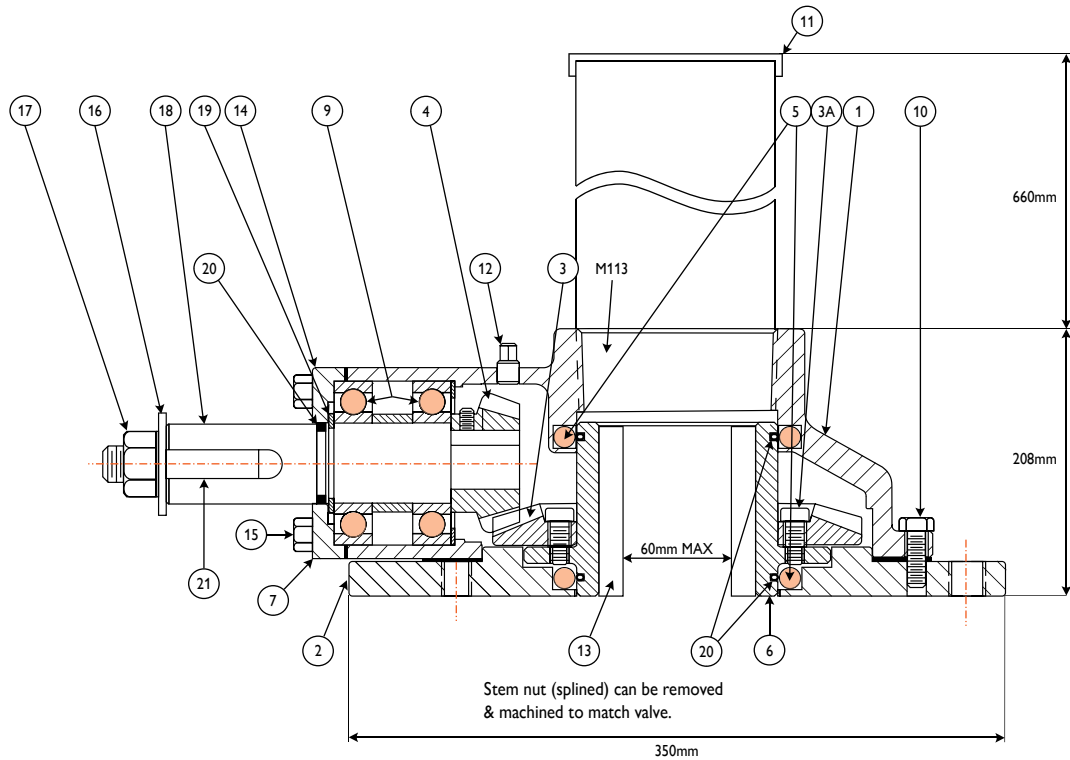

MOUNTING PATTERN

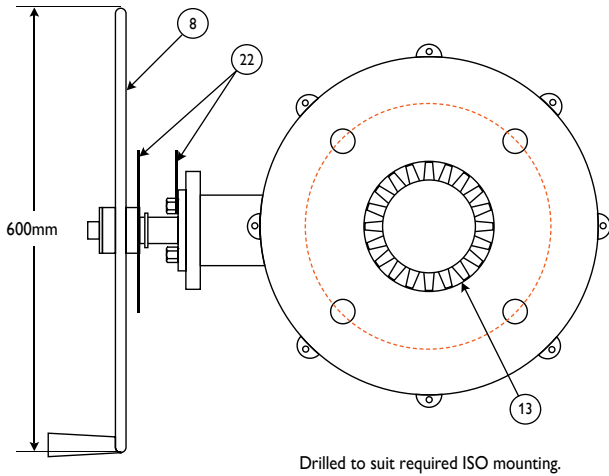

Handwheel & Stem Protector Included

PARTS AND BILL OF MATERIALS

No	Part Name	Qty	Material
1	Housing	1	Carbon Steel
2	Base	1	Carbon Steel
3	Bevel Gear	1	1045 Carbon Steel
3A	Bevel Gear Capscrew	6	Carbon Steel
4	Pinion Gear & Input Shaft	1	1045 Carbon Steel + ENP
5	Bearing Balls	47	GCR15
6	Drive Sleeve	1	Ductile Iron
7	Cover	4	Carbon Steel
8	Handwheel	1	Assembly + FBE
9	Ball Bearing	2	Commercial
10	Bolt	10	Carbon Steel
11	Stem Protector & Cap	1	Steel Pipe - Galvanised
12	Grease Nipple	1	AISI 1020 + ZP
13	Stem Nut Insert	1	Brass H62
14	Cap	1	Carbon Steel
15	Bolt	1	1045 Carbon Steel + ZP
16	Washer	1	Steel + ZP
17	Nut	1	Brass or 2H
18	Pinion Gear Input Shaft	1	1045 + ENP
19	Snap Ring	3	Spring Steel 65 MN
20	O-Ring	2	EPDM
21	Key	1	A3 + ZP
22	Locking Device	1	A3 + ZP + FBE

No couplings or brackets are supplied. The splined stem nut insert (13) in gearbox can be removed and ACME threaded to match valve stem. Alternatively the stem nut from your existing valve can be utilised, a simple coupler then needs to be made to match gear box.

QUICK REFERENCE

Unit Type	Weight in KG W/O Wheel	Output Torque NM	Input Torque NM	Unit Ratio	Maximum Stem Diameter	Maximum Thrust
BA-2	28	2940	600	5.2:1	60mm	308KN

BA-3 BEVEL GEAR OPERATOR

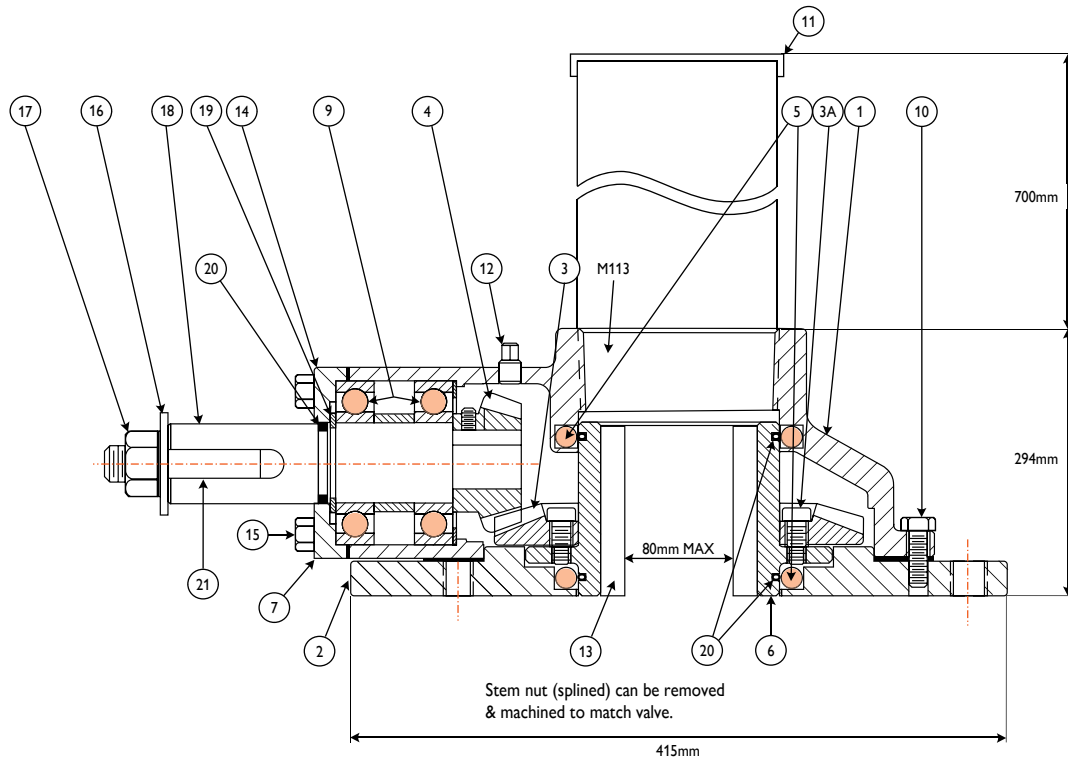

MOUNTING PATTERN

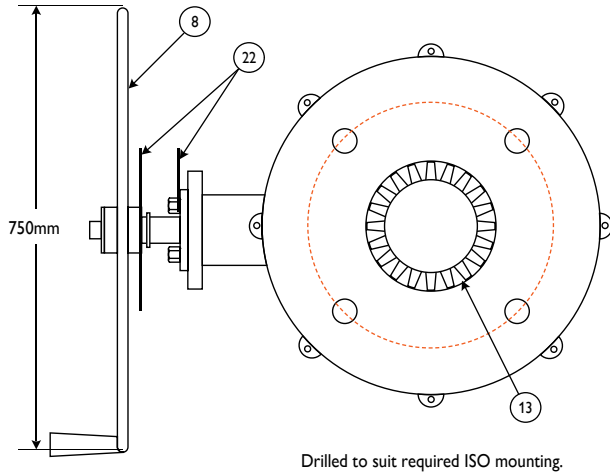

Handwheel & Stem Protector Included

PARTS AND BILL OF MATERIALS

No	Part Name	Qty	Material
1	Housing	1	Carbon Steel
2	Base	1	Carbon Steel
3	Bevel Gear	1	1045 Carbon Steel
3A	Bevel Gear Capscrew	6	Carbon Steel
4	Pinion Gear & Input Shaft	1	1045 Carbon Steel + ENP
5	Bearing Balls	47	GCR15
6	Drive Sleeve	1	Ductile Iron
7	Cover	4	Carbon Steel
8	Handwheel	1	Assembly + FBE
9	Ball Bearing	2	Commercial
10	Bolt	10	Carbon Steel
11	Stem Protector & Cap	1	Steel Pipe - Galvanised
12	Grease Nipple	1	AISI 1020 + ZP
13	Stem Nut Insert	1	Bronze C95200
14	Cap	1	Carbon Steel
15	Bolt	1	1045 Carbon Steel + ZP
16	Washer	1	Steel + ZP
17	Nut	1	Brass or 2H
18	Pinion Gear Input Shaft	1	1045 + ENP
19	Snap Ring	3	Spring Steel 65 MN
20	O-Ring	2	EPDM
21	Key	1	A3 + ZP
22	Locking Device	1	A3 + ZP + FBE

No couplings or brackets are supplied. The splined stem nut insert (13) in gearbox can be removed and ACME threaded to match valve stem. Alternatively the stem nut from your existing valve can be utilised, a simple coupler then needs to be made to match gear box.

QUICK REFERENCE

Unit Type	Weight in KG W/O Wheel	Output Torque NM	Input Torque NM	Unit Ratio	Maximum Stem Diameter	Maximum Thrust
BA-3	230	4000	700	5.7:1	80mm	402KN

WORM GEAR OPERATOR

External mechanical stops allow +/-5° travel.

Fully weather resistant and permanently lubricated along with gears and bearings.

High strength cast iron enclosure.

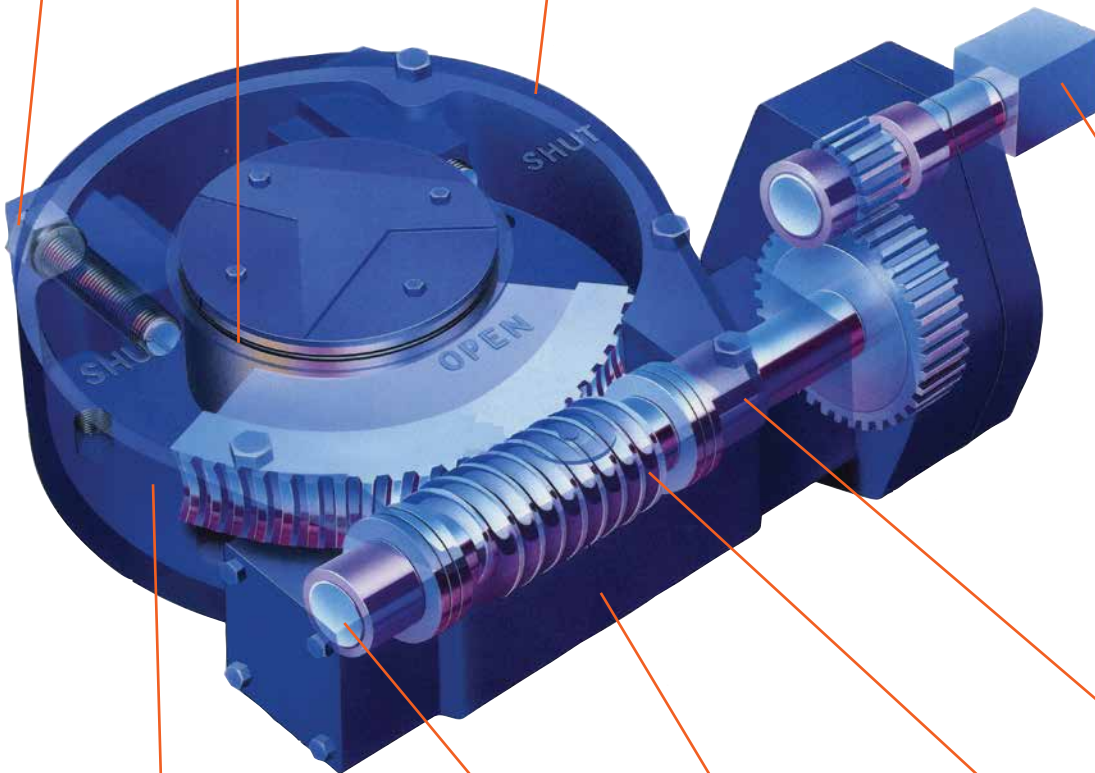

Optional square operating nut allows for removal of handwheel and operation by a reach rod.
*Easily converted for motorized applications.

Industry inter-changeable pre-drilled mounting pattern per MSS SP 101.

Custom gear mounting pattern, boring and keyway patterns.

Worm gear dual position mounting capability for easy reversal of rotation direction.

Comprehensive product line for torque capability.

Machine generated self-lock gearing assures minimum backlash and smooth operation.

Thrust bearings provide reliable smooth operation

0-360° Worm Gearboxes

Can be manually set for any rotation from 0 to 360 degrees. Used in applications that require selectable 'partial stroke' adjustments where applications do not permit full 90, 180, 270 or 360 degree travel. (Refer to Drawing)

Vertical Stem Worm Gearboxes - Buried Service

c/w Bevel Gearbox c/w Right Angle Mitre Box

*Heavy duty components must be specified for motor operation

WG007 WORM GEAR OPERATOR

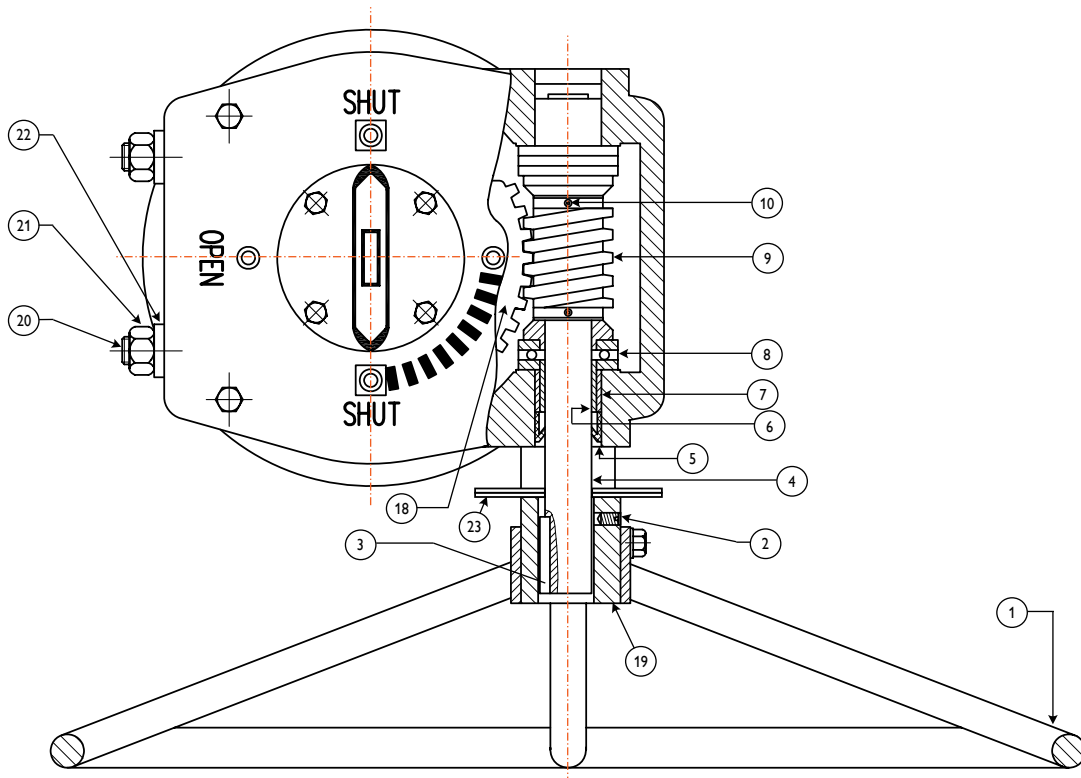

PARTS AND BILL OF MATERIALS

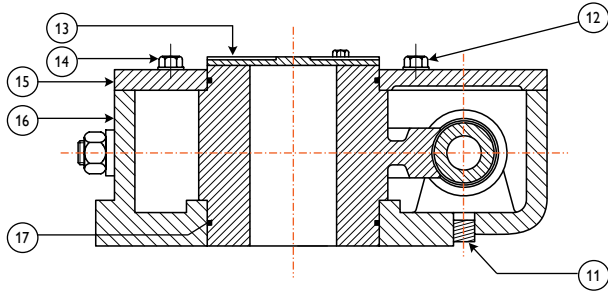

No	Part Name	Material
1	Handwheel	Carbon Steel
2	Set Screw	Carbon Steel
3	Stem Key	Carbon Steel
4	Input Shaft	AISI 1045 + ENP
5	Oil Seal	Rubber
6	Bearing	Cu-Base Alloy
7	Oil Bearing	Cu-Base Alloy
8	Thrust Bearing	Commercial
9	Worm	AISI 1045
10	Pin	Carbon Steel
11	Plug	Carbon Steel
12	Bolt	Carbon Steel
13	Indicator Plate	Cast Iron
14	Bolt	Carbon Steel
15	Cover	Cast Iron
16	Housing	Cast Iron
17	O-Ring	Rubber
18	Worm Gear	Ductile Iron
19	Operating Nut	Carbon Steel
20	Stop Screw	Carbon Steel
21	Hex Nut	Carbon Steel
22	Lock Washer	Carbon Steel
23	Locking Device	Steel + ZP

QUICK REFERENCE

Unit Type	Approximate Weight in KG W/O Wheel	Maximum Output Torque NM	Input Torque NM	Unit Ratio	Maximum Bore Size Square Keyway	Maximum Bore Size Rectangular Keyway	Minimum Bore Size MM	Mounting ISO
WG007	14	720	80	42:1	38.1mm WITH 12.7mm X 12.7mm KEYWAY	39.88mm WITH 12.7mm x 9.53mm KEYWAY	15.88	F12

* Other drillings on request

WG008 WORM GEAR OPERATOR

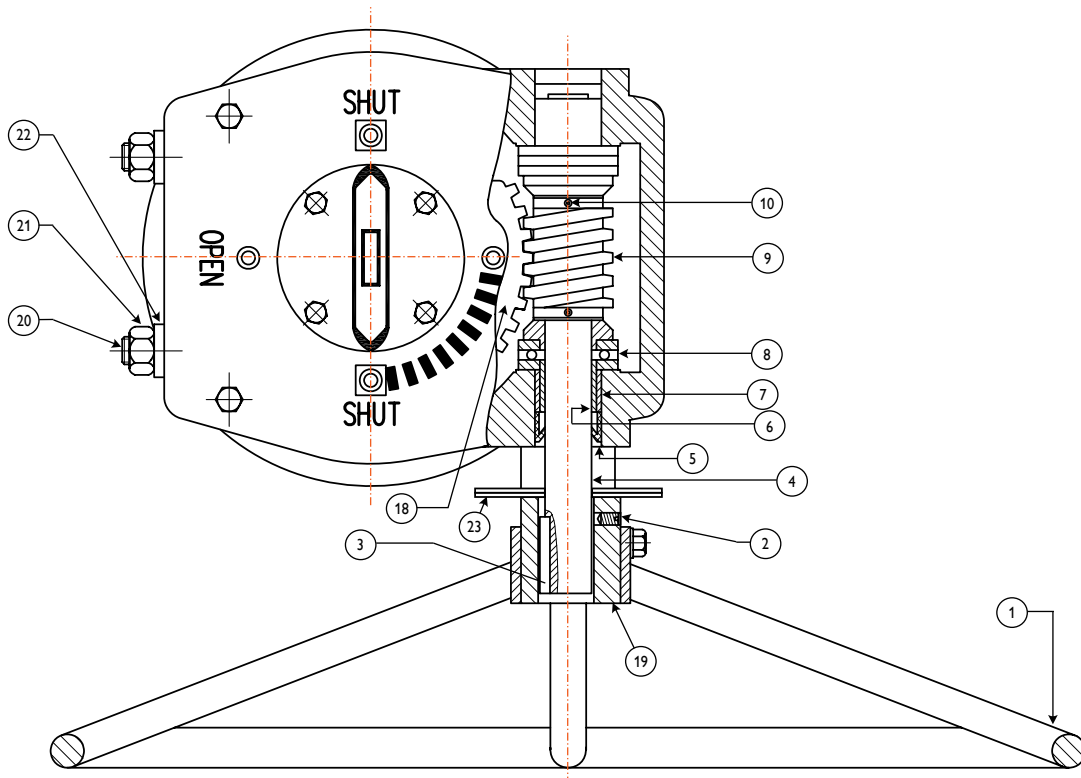

PARTS AND BILL OF MATERIALS

No	Part Name	Material
1	Handwheel	Carbon Steel
2	Set Screw	Carbon Steel
3	Stem Key	Carbon Steel
4	Input Shaft	AISI 1045 + ENP
5	Oil Seal	Rubber
6	Bearing	Cu-Base Alloy
7	Oil Bearing	Cu-Base Alloy
8	Thrust Bearing	Commercial
9	Worm	AISI 1045
10	Pin	Carbon Steel
11	Plug	Carbon Steel
12	Bolt	Carbon Steel
13	Indicator Plate	Cast Iron
14	Bolt	Carbon Steel
15	Cover	Cast Iron
16	Housing	Cast Iron
17	O-Ring	Rubber
18	Worm Gear	Ductile Iron
19	Operating Nut	Carbon Steel
20	Stop Screw	Carbon Steel
21	Hex Nut	Carbon Steel
22	Lock Washer	Carbon Steel
23	Locking Device	Steel + ZP

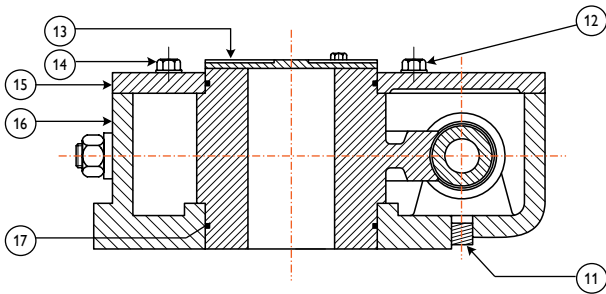

QUICK REFERENCE

Unit Type	Approximate Weight in KG W/O Wheel	Maximum Output Torque NM	Input Torque NM	Unit Ratio	Maximum Bore Size Square Keyway	Maximum Bore Size Rectangular Keyway	Minimum Bore Size MM	Mounting ISO
WG008	14	1219	110	50:1	38.1mm WITH 12.7mm X 12.7mm KEYWAY	39.88mm WITH 12.7mm x 9.53mm KEYWAY	15.88	F14

* Other drillings on request

WG108 WORM GEAR OPERATOR

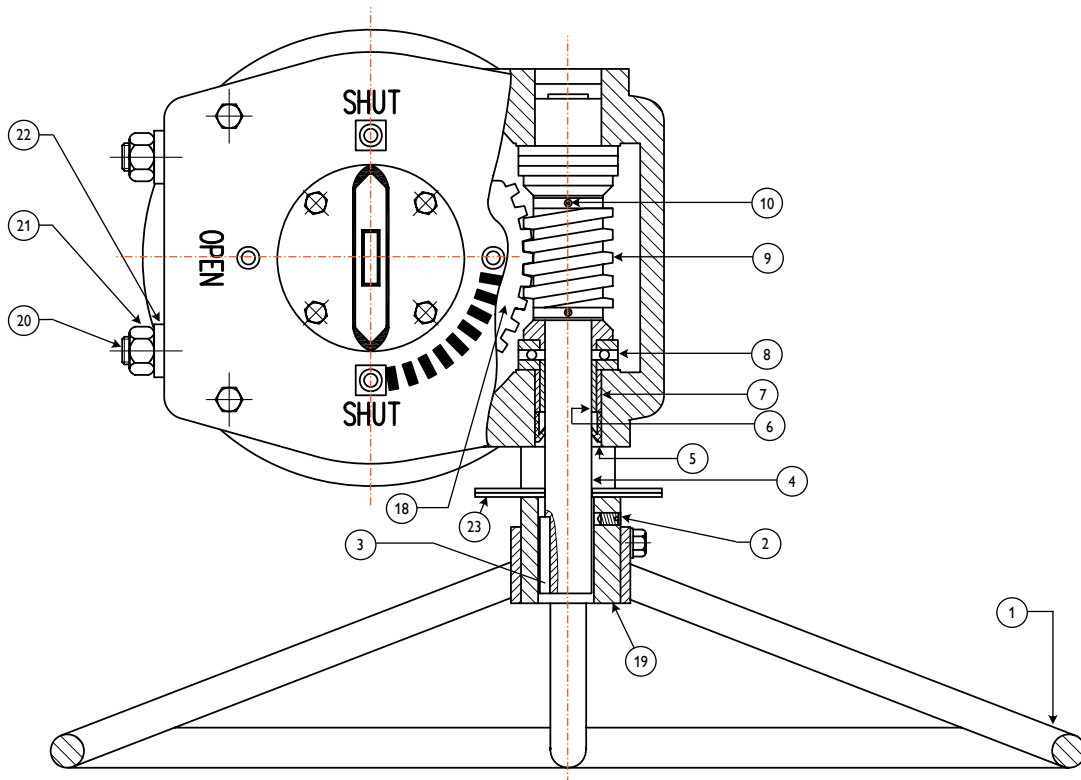

PARTS AND BILL OF MATERIALS

No	Part Name	Material
1	Handwheel	Carbon Steel
2	Set Screw	Carbon Steel
3	Stem Key	Carbon Steel
4	Input Shaft	AISI 1045 + ENP
5	Oil Seal	Rubber
6	Bearing	Cu-Base Alloy
7	Oil Bearing	Cu-Base Alloy
8	Thrust Bearing	Commercial
9	Worm	AISI 1045
10	Pin	Carbon Steel
11	Plug	Carbon Steel
12	Bolt	Carbon Steel
13	Indicator Plate	Cast Iron
14	Bolt	Carbon Steel
15	Cover	Cast Iron
16	Housing	Cast Iron
17	O-Ring	Rubber
18	Worm Gear	Ductile Iron
19	Operating Nut	Carbon Steel
20	Stop Screw	Carbon Steel
21	Hex Nut	Carbon Steel
22	Lock Washer	Carbon Steel
23	Locking Device	Steel + ZP

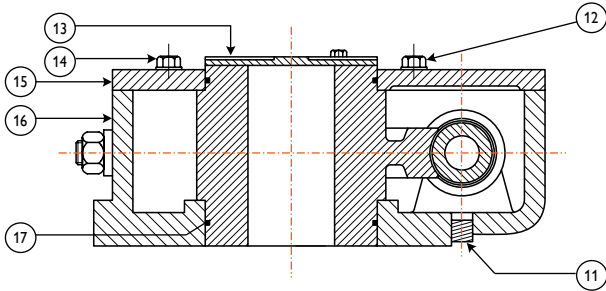

QUICK REFERENCE

Unit Type	Approximate Weight in KG W/O Wheel	Maximum Output Torque NM	Input Torque NM	Unit Ratio	Maximum Bore Size Square Keyway	Maximum Bore Size Rectangular Keyway	Minimum Bore Size MM	Mounting ISO
WG108	15.5	2200	120	72:1	47.8mm WITH 12.7mm X 12.7mm KEYWAY	49.3mm WITH 12.7mm x 9.53mm KEYWAY	20	F16

* Other drillings on request

WG158 WORM GEAR OPERATOR

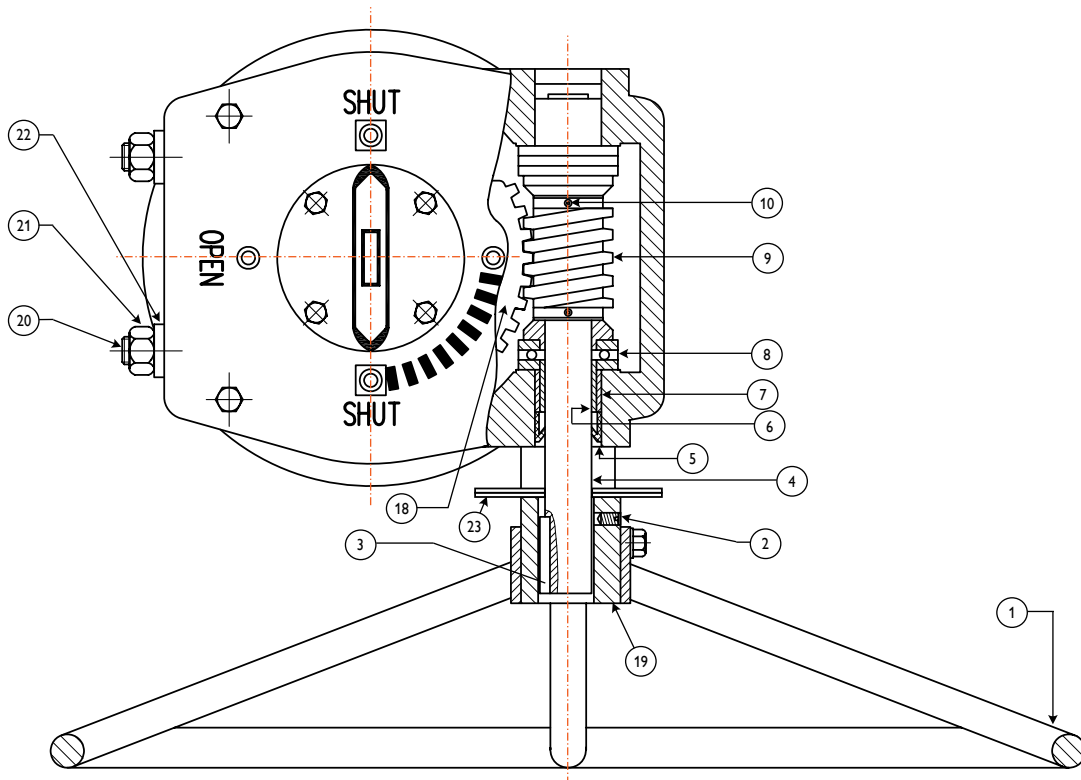

PARTS AND BILL OF MATERIALS

No	Part Name	Material
1	Handwheel	Carbon Steel
2	Set Screw	Carbon Steel
3	Stem Key	Carbon Steel
4	Input Shaft	AISI 1045 + ENP
5	Oil Seal	Rubber
6	Bearing	Cu-Base Alloy
7	Oil Bearing	Cu-Base Alloy
8	Thrust Bearing	Commercial
9	Worm	AISI 1045
10	Pin	Carbon Steel
11	Plug	Carbon Steel
12	Bolt	Carbon Steel
13	Indicator Plate	Cast Iron
14	Bolt	Carbon Steel
15	Cover	Cast Iron
16	Housing	Cast Iron
17	O-Ring	Rubber
18	Worm Gear	Ductile Iron
19	Operating Nut	Carbon Steel
20	Stop Screw	Carbon Steel
21	Hex Nut	Carbon Steel
22	Lock Washer	Carbon Steel
23	Locking Device	Steel + ZP

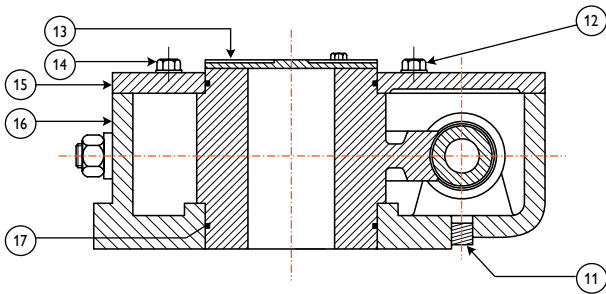

QUICK REFERENCE

Unit Type	Approximate Weight in KG W/O Wheel	Maximum Output Torque NM	Input Torque NM	Unit Ratio	Maximum Bore Size Square Keyway 12.7mm X 12.7mm KEYWAY	Maximum Bore Size Rectangular Keyway 49.3mm WITH 12.7mm x 9.53mm KEYWAY	Minimum Bore Size MM	Mounting Pattern MSS SP-101
WG158	15.5	2500	150	70:1	47.8mm WITH 12.7mm X 12.7mm KEYWAY	49.3mm WITH 12.7mm x 9.53mm KEYWAY	20	F14

* Other drillings on request

WG208 WORM GEAR OPERATOR

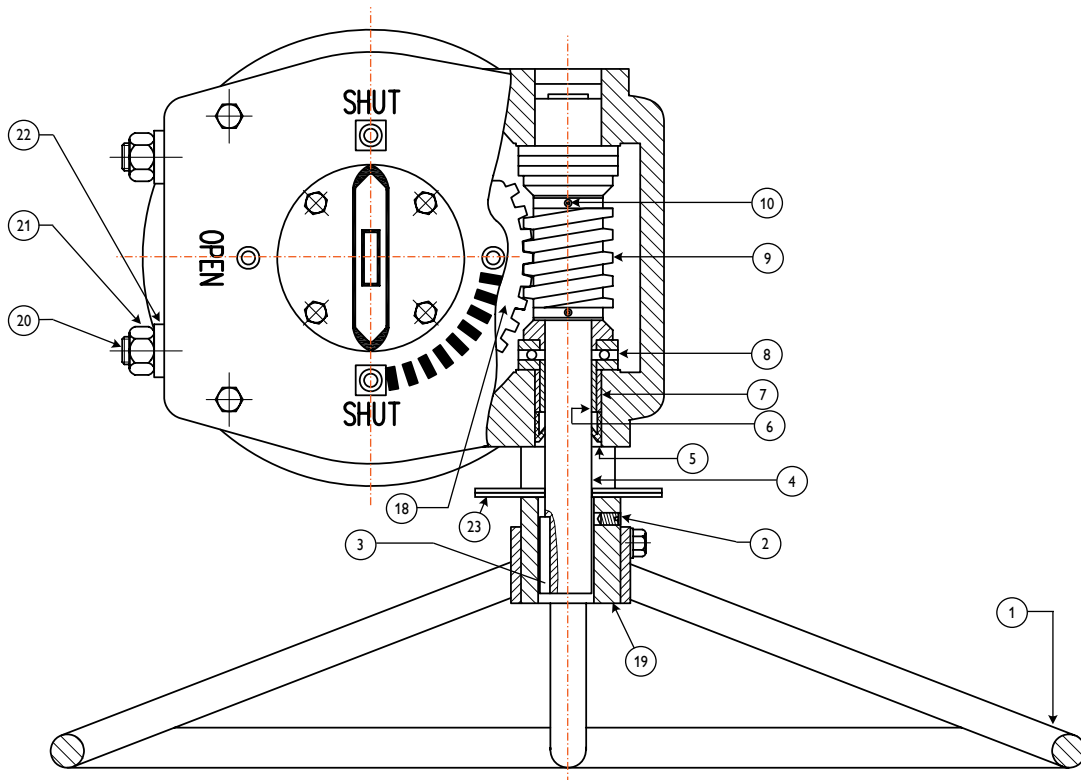

PARTS AND BILL OF MATERIALS

No	Part Name	Material
1	Handwheel	Carbon Steel
2	Set Screw	Carbon Steel
3	Stem Key	Carbon Steel
4	Input Shaft	AISI 1045 + ENP
5	Oil Seal	Rubber
6	Bearing	Cu-Base Alloy
7	Oil Bearing	Cu-Base Alloy
8	Thrust Bearing	Commercial
9	Worm	AISI 1045
10	Pin	Carbon Steel
11	Plug	Carbon Steel
12	Bolt	Carbon Steel
13	Indicator Plate	Cast Iron
14	Bolt	Carbon Steel
15	Cover	Cast Iron
16	Housing	Cast Iron
17	O-Ring	Rubber
18	Worm Gear	Ductile Iron
19	Operating Nut	Carbon Steel
20	Stop Screw	Carbon Steel
21	Hex Nut	Carbon Steel
22	Lock Washer	Carbon Steel
23	Locking Device	Steel + ZP

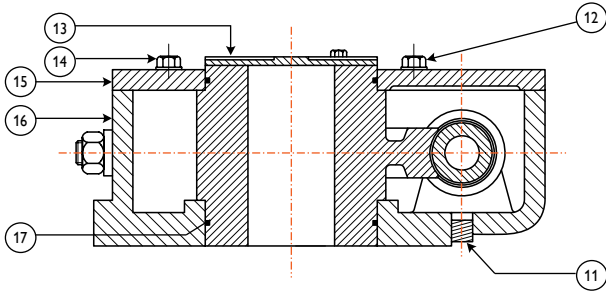

QUICK REFERENCE

Unit Type	Approximate Weight in KG W/O Wheel	Maximum Output Torque NM	Input Torque NM	Unit Ratio	Maximum Bore Size		Minimum Bore Size MM	Mounting ISO
					Square Keyway	Rectangular Keyway		
WG208	32.73	4475	220	68:1	76.4mm WITH 22mm x 22mm KEYWAY	79.3mm WITH 15.88mm x 11.11mm KEYWAY	38.1mm	ISO F19 & F25

* Other drillings on request

WG238 WORM GEAR OPERATOR

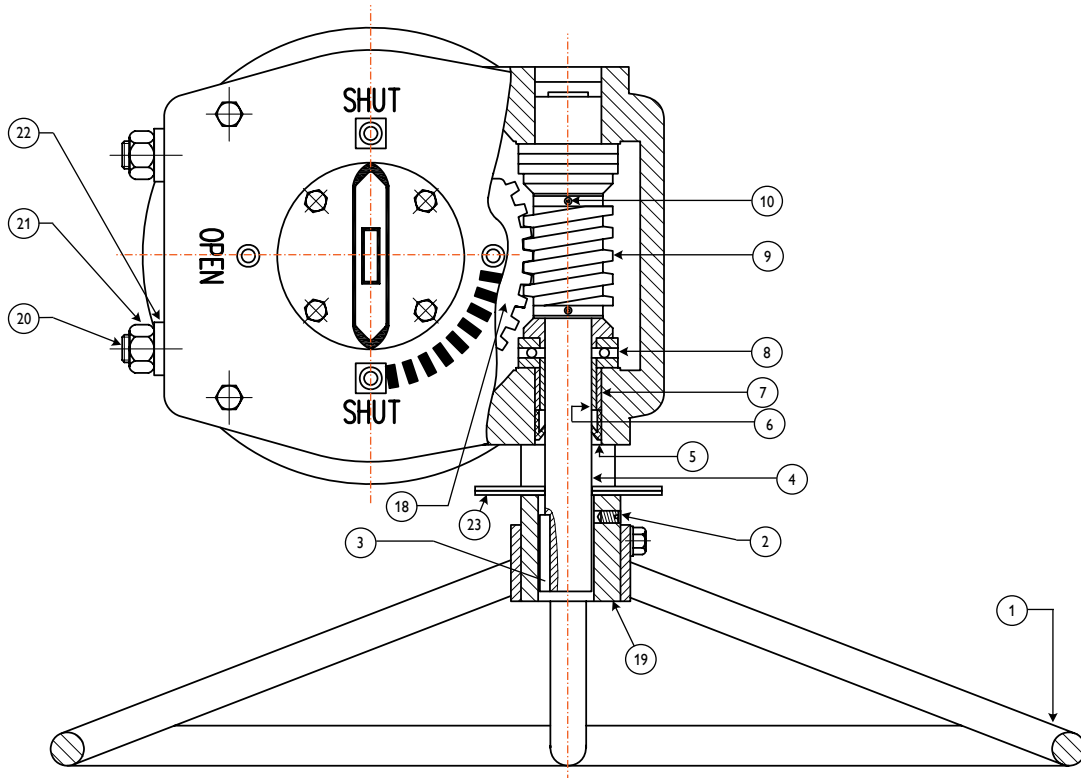

PARTS AND BILL OF MATERIALS

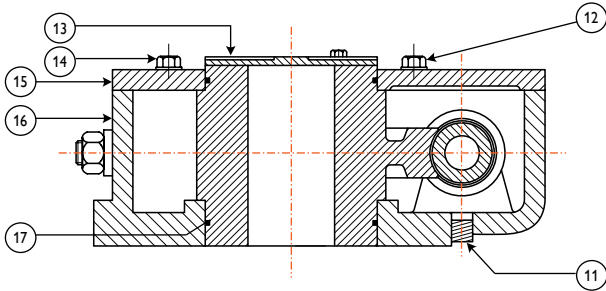

No	Part Name	Material
1	Handwheel	Carbon Steel
2	Set Screw	Carbon Steel
3	Stem Key	Carbon Steel
4	Input Shaft	AISI 1045 + ENP
5	Oil Seal	Rubber
6	Bearing	Cu-Base Alloy
7	Oil Bearing	Cu-Base Alloy
8	Thrust Bearing	Commercial
9	Worm	AISI 1045
10	Pin	Carbon Steel
11	Plug	Carbon Steel
12	Bolt	Carbon Steel
13	Indicator Plate	Cast Iron
14	Bolt	Carbon Steel
15	Cover	Cast Iron
16	Housing	Cast Iron
17	O-Ring	Rubber
18	Worm Gear	Ductile Iron
19	Operating Nut	Carbon Steel
20	Stop Screw	Carbon Steel
21	Hex Nut	Carbon Steel
22	Lock Washer	Carbon Steel
23	Locking Device	Steel + ZP

QUICK REFERENCE

Unit Type	Approximate Weight in KG W/O Wheel	Maximum Output Torque NM	Input Torque NM	Unit Ratio	Maximum Bore Size		Minimum Bore Size MM	Mounting ISO
					Square Keyway	Rectangular Keyway		
WG238	32.73	6250	170	175:1	76.4mm WITH 22mm x 22mm KEYWAY	79.3mm WITH 15.88mm x 11.11mm KEYWAY	38.1mm	F25

* Other drillings on request

WG308 WORM GEAR OPERATOR

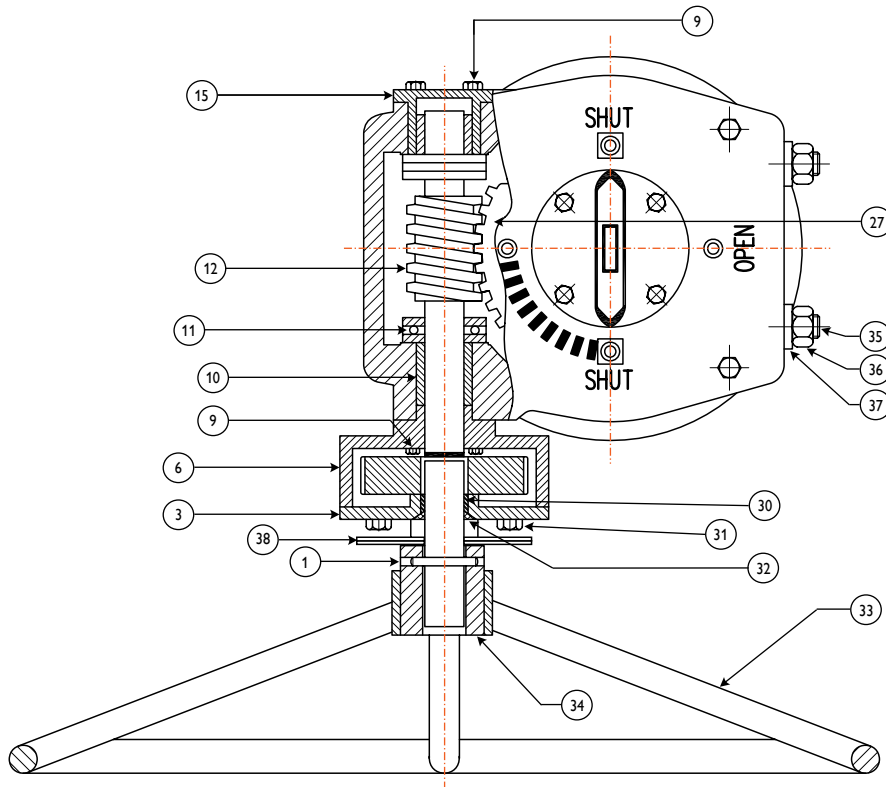

PARTS AND BILL OF MATERIALS

No	Part Name	Qty	Material
1	Slotted Spring Pin	1	Carbon Steel
3	Spur Gear Cover	1	Cast Iron
5	Input Shaft	1	AISI 1045 + ENP
6	Spur Gear Housing	1	Cast Iron
9	Bolt	4	Carbon Steel
10	Bearing	1	Cu-Base Alloy
11	Thrust Bearing	1	Commercial
12	Worm	1	AISI 1045
15	Bearing Block	1	Carbon Steel
17	Locator Pins	2	Carbon Steel
18	Bolt	4	Carbon Steel
19	Indicator Plate	1	Cast Iron
20	Cover	1	Cast Iron
21	Housing	1	Cast Iron
22	O-Ring	2	Rubber
27	Worm Gear	1	Ductile Iron
28	Spur Gear	1	Carbon Steel
30	Bearing	1	Cu-Base Alloy
31	Bolt	4	Carbon Steel
32	Seal Cover	1	Rubber
33	Handwheel	1	Carbon Steel
34	2" SQ. Operating Unit	1	Carbon Steel
35	Stopscrew	2	Carbon Steel
36	Hex Nut	2	Carbon Steel
37	Lockwasher	2	Carbon Steel
38	Locking Device	1	Steel + ZP

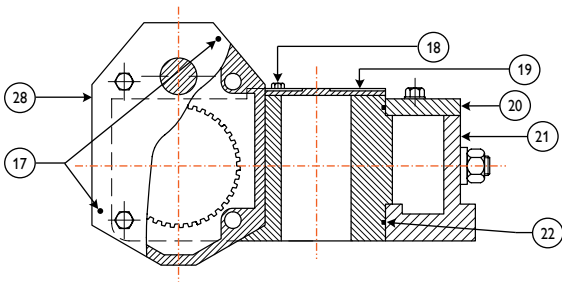

QUICK REFERENCE

Unit Type	Approximate Weight in KG W/O Wheel	Maximum Output Torque NM	Input Torque NM	Unit Ratio	Maximum Bore Size		Minimum Bore Size MM	Mounting ISO
					Square Keyway	Rectangular Keyway		
WG308	93	9800	150	275:1	95.25mm WITH 29.02mm x 29.02mm KEYWAY	101.6mm WITH 25.4mm x 19.05mm KEYWAY	57.15mm	F25

* Other drillings on request

WG358 WORM GEAR OPERATOR

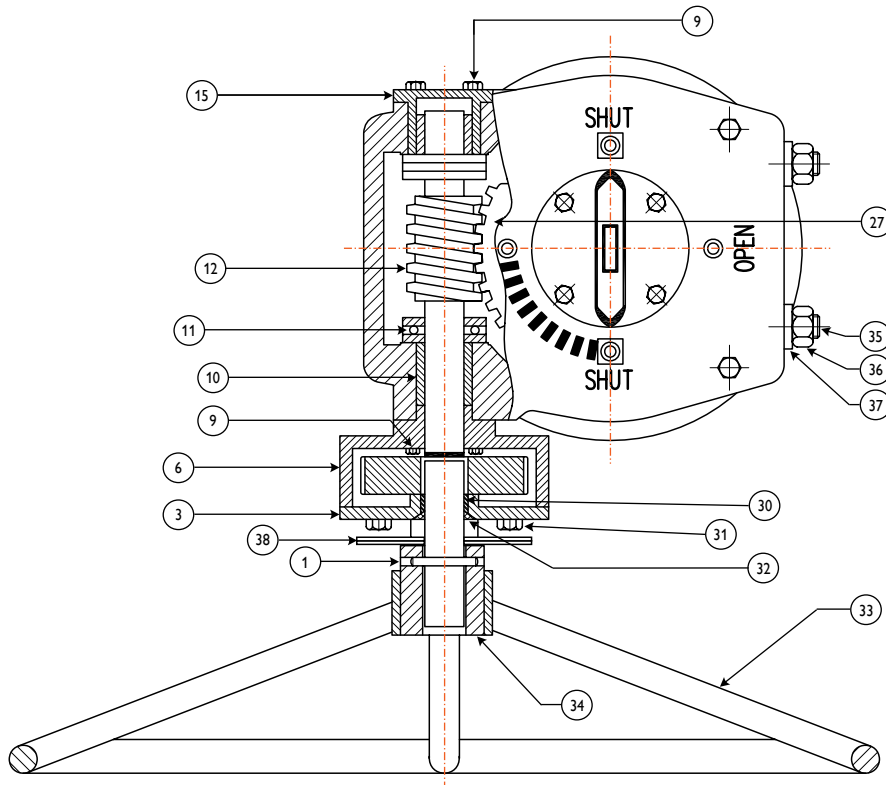

PARTS AND BILL OF MATERIALS

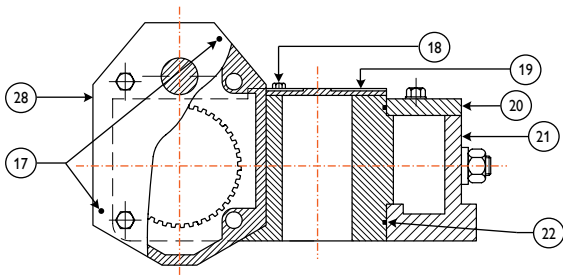

No	Part Name	Qty	Material
1	Slotted Spring Pin	1	Carbon Steel
3	Spur Gear Cover	1	Cast Iron
5	Input Shaft	1	AISI 1045 + ENP
6	Spur Gear Housing	1	Cast Iron
9	Bolt	4	Carbon Steel
10	Bearing	1	Cu-Base Alloy
11	Thrust Bearing	1	Commercial
12	Worm	1	AISI 1045
15	Bearing Block	1	Carbon Steel
17	Locator Pins	2	Carbon Steel
18	Bolt	4	Carbon Steel
19	Indicator Plate	1	Cast Iron
20	Cover	1	Cast Iron
21	Housing	1	Cast Iron
22	O-Ring	2	Rubber
27	Worm Gear	1	Ductile Iron
28	Spur Gear	1	Carbon Steel
30	Bearing	1	Cu-Base Alloy
31	Bolt	4	Carbon Steel
32	Seal Cover	1	Rubber
33	Handwheel	1	Carbon Steel
34	2" SQ. Operating Unit	1	Carbon Steel
35	Stopscrew	2	Carbon Steel
36	Hex Nut	2	Carbon Steel
37	Lockwasher	2	Carbon Steel
38	Locking Device	1	Steel + ZP

QUICK REFERENCE

Unit Type	Approximate Weight in KG W/O Wheel	Maximum Output Torque NM	Input Torque NM	Unit Ratio	Maximum Bore Size		Minimum Bore Size MM	Mounting ISO
					Square Keyway	Rectangular Keyway		
WG358	93	18000	170	532:1	95.25mm WITH 29.02mm x 29.02mm KEYWAY	101.6mm WITH 25.4mm x 19.05mm KEYWAY	57.15mm	F30

* Other drillings on request

WG408 WORM GEAR OPERATOR

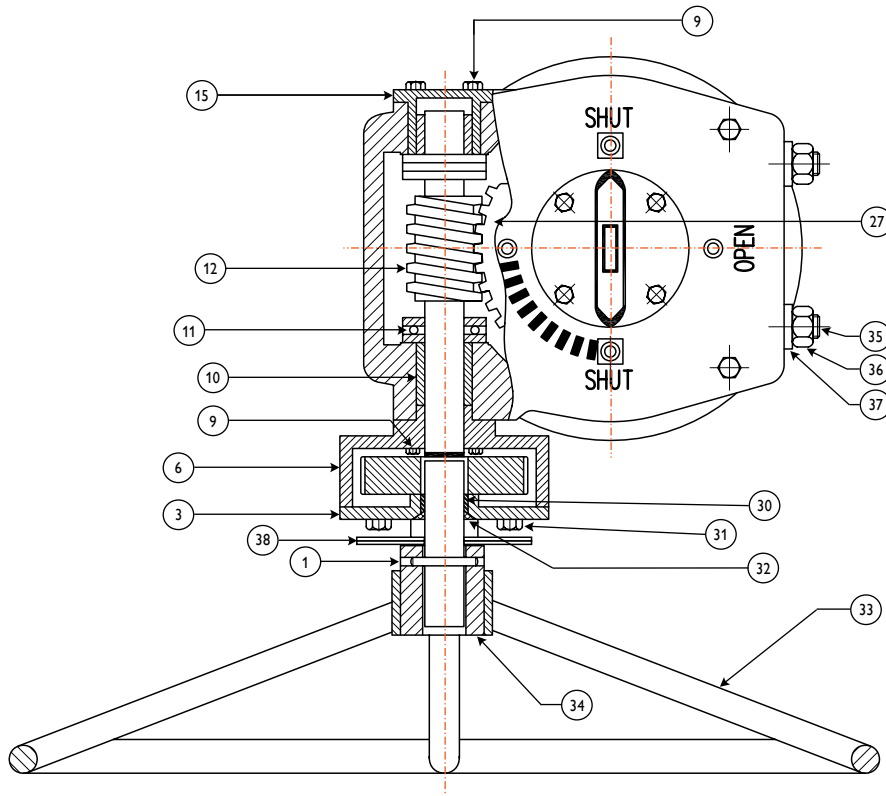

PARTS AND BILL OF MATERIALS

No	Part Name	Qty	Material
1	Slotted Spring Pin	1	Carbon Steel
3	Spur Gear Cover	1	Cast Iron
5	Input Shaft	1	AISI 1045 + ENP
6	Spur Gear Housing	1	Cast Iron
9	Bolt	4	Carbon Steel
10	Bearing	1	Cu-Base Alloy
11	Thrust Bearing	1	Commercial
12	Worm	1	AISI 1045
15	Bearing Block	1	Carbon Steel
17	Locator Pins	2	Carbon Steel
18	Bolt	4	Carbon Steel
19	Indicator Plate	1	Cast Iron
20	Cover	1	Cast Iron
21	Housing	1	Cast Iron
22	O-Ring	2	Rubber
27	Worm Gear	1	Ductile Iron
28	Spur Gear	1	Carbon Steel
30	Bearing	1	Cu-Base Alloy
31	Bolt	4	Carbon Steel
32	Seal Cover	1	Rubber
33	Handwheel	1	Carbon Steel
34	2" Sq. Operating Unit	1	Carbon Steel
35	Stopscrew	2	Carbon Steel
36	Hex Nut	2	Carbon Steel
37	Lockwasher	2	Carbon Steel
38	Locking Device	1	Steel + ZP

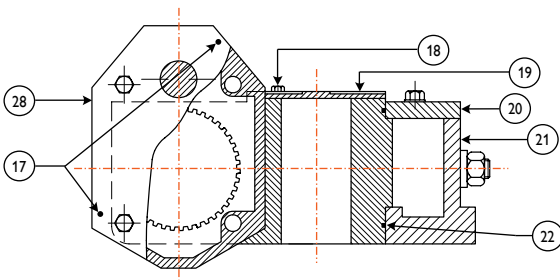

QUICK REFERENCE

Unit Type	Approximate Weight in KG W/O Wheel	Maximum Output Torque NM	Input Torque NM	Unit Ratio	Maximum Bore Size		Minimum Bore Size MM	Mounting ISO
					Square Keyway	Rectangular Keyway		
WG408	207	32000	190	700:1	143mm WITH 38.1mm x 38.1mm KEYWAY	155.45mm WITH 38.1mm x 25.4mm KEYWAY	74.93mm	F35

* Other drillings on request

WG448 WORM GEAR OPERATOR

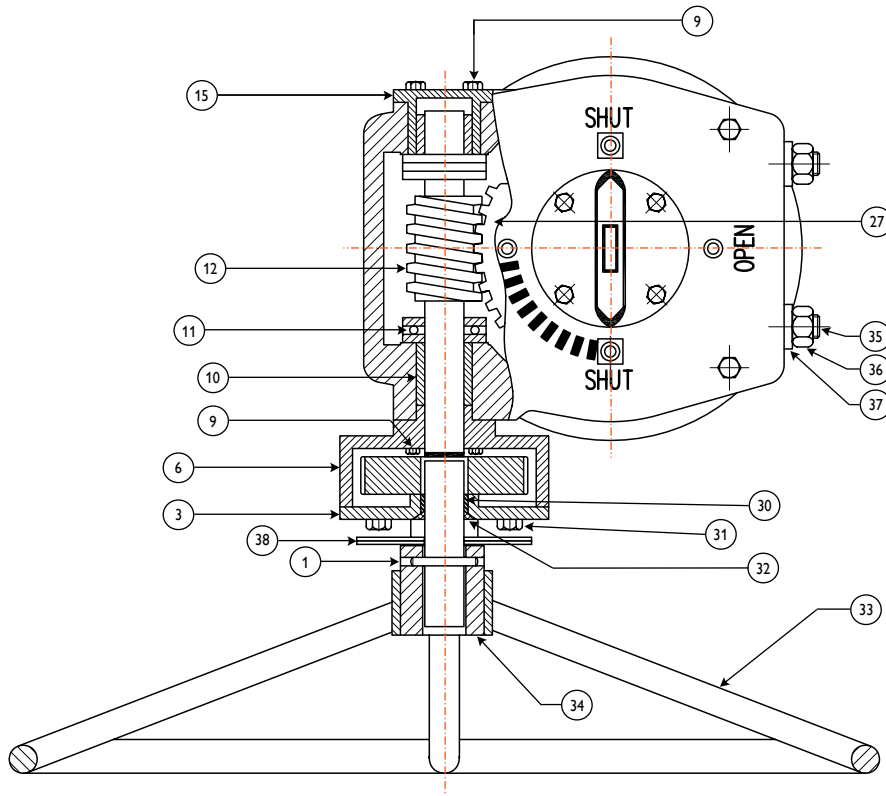

PARTS AND BILL OF MATERIALS

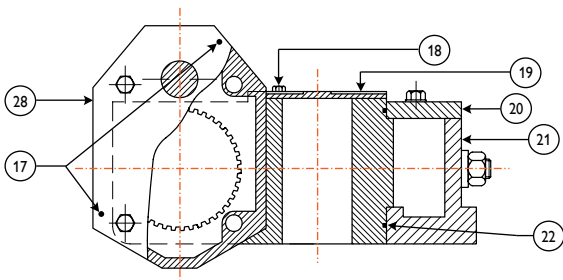

No	Part Name	Qty	Material
1	Slotted Spring Pin	1	Carbon Steel
3	Spur Gear Cover	1	Cast Iron
5	Input Shaft	1	AISI 1045 + ENP
6	Spur Gear Housing	1	Cast Iron
9	Bolt	4	Carbon Steel
10	Bearing	1	Cu-Base Alloy
11	Thrust Bearing	1	Commercial
12	Worm	1	AISI 1045
15	Bearing Block	1	Carbon Steel
17	Locator Pins	2	Carbon Steel
18	Bolt	4	Carbon Steel
19	Indicator Plate	1	Cast Iron
20	Cover	1	Cast Iron
21	Housing	1	Cast Iron
22	O-Ring	2	Rubber
27	Worm Gear	1	Ductile Iron
28	Spur Gear	1	Carbon Steel
30	Bearing	1	Cu-Base Alloy
31	Bolt	4	Carbon Steel
32	Seal Cover	1	Rubber
33	Handwheel	1	Carbon Steel
34	2" Sq. Operating Unit	1	Carbon Steel
35	Stopscrew	2	Carbon Steel
36	Hex Nut	2	Carbon Steel
37	Lockwasher	2	Carbon Steel
38	Locking Device	1	Steel + ZP

QUICK REFERENCE

Unit Type	Approximate Weight in KG W/O Wheel	Maximum Output Torque NM	Input Torque NM	Unit Ratio	Maximum Bore Size		Minimum Bore Size MM	Mounting ISO
					Square Keyway	Rectangular Keyway		
WG448	207	42000	165	1233:1	143mm WITH 38.1mm x 38.1mm KEYWAY	155.45mm WITH 38.1mm x 25.4mm KEYWAY	74.93mm	F35

* Other drillings on request

WG508 WORM GEAR OPERATOR

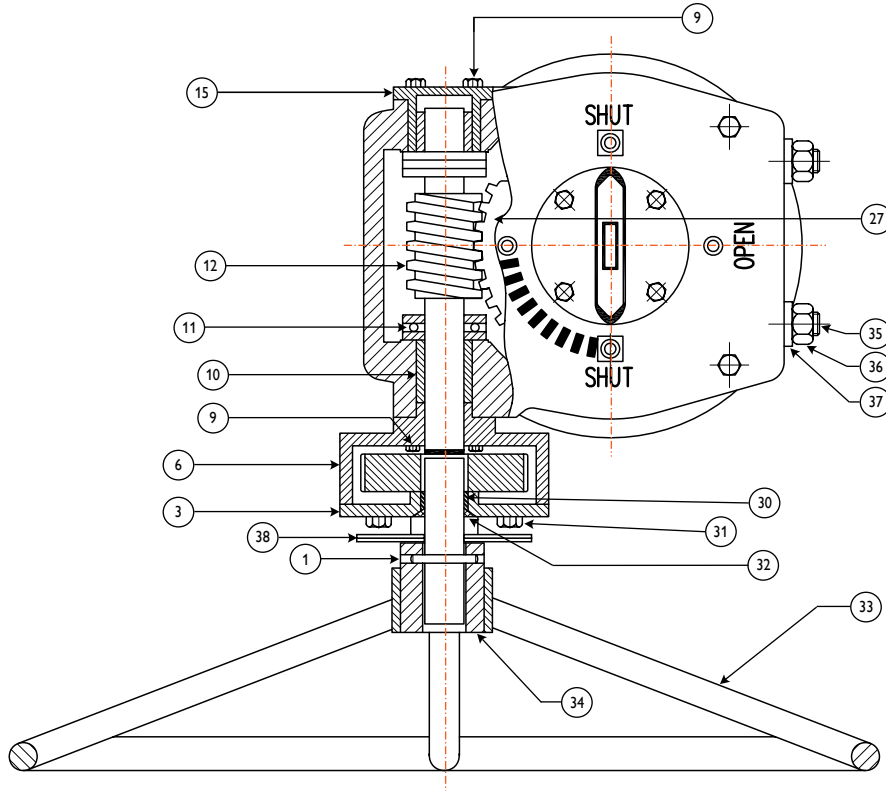

PARTS AND BILL OF MATERIALS

No	Part Name	Qty	Material
1	Slotted Spring Pin	1	Carbon Steel
3	Spur Gear Cover	1	Cast Iron
5	Input Shaft	1	AISI 1045 + ENP
6	Spur Gear HO	1	Cast Iron
9	Bolt	4	Carbon Steel
10	Bearing	1	Cu-Base Alloy
11	Thrust Bearing	1	Commercial
12	Worm	1	AISI 1045
15	Bearing Block	1	Carbon Steel
17	Locator Pins	2	Carbon Steel
18	Bolt	4	Carbon Steel
19	Indicator Plate	1	Cast Iron
20	Cover	1	Cast Iron
21	Housing	1	Cast Iron
22	O-Ring	2	Rubber
27	Worm Gear	1	Ductile Iron
28	Spur Gear	1	Carbon Steel
30	Bearing	1	Cu-Base Alloy
31	Bolt	4	Carbon Steel
32	Seal Cover	1	Rubber
33	Handwheel	1	Carbon Steel
34	2" Sq. Operating Unit	1	Carbon Steel
35	Stopscrew	2	Carbon Steel
36	Hex Nut	2	Carbon Steel
37	Lockwasher	2	Carbon Steel
38	Locking Device	1	Steel + ZP

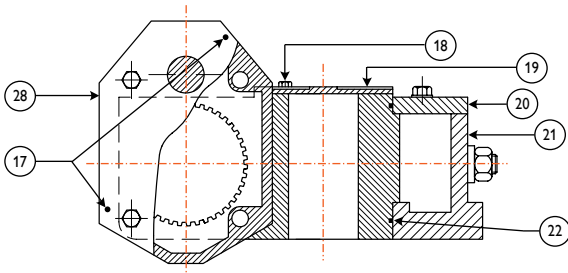

QUICK REFERENCE

Unit Type	Approximate Weight in KG W/O Wheel	Maximum Output Torque NM	Input Torque NM	Unit Ratio	Maximum Bore Size Square Keyway	Maximum Bore Size Rectangular Keyway	Minimum Bore Size MM	Mounting ISO
WG508	316	60000	190	1254:1	218mm WITH 50mm x 50mm KEYWAY	230mm WITH 50mm x 38mm KEYWAY	89mm	F40

DC SERIES WORM GEAR OPERATOR

PARTS AND BILL OF MATERIALS

No.	Part Name	Materials
1	Gear Body	ASTM A536 65-45-12
2	Cover	ASTM A536 65-45-12
3	O-Ring	NBR
4	Gear	ASTM A536 65-45-12
5	Bolt	8.8
6	Locking Device	1025
7	Shaft	1045 + Nitrided
8	Position Indicator	A36
9	Adjusting Screw	8.8
10	Handwheel	ASTM A536 65-45-12

PERFORMANCE

Model	Speed Ratio	Torque N.M.		Torque amplification factor $\pm 10\%$
		Input	Output	
DGAB24	24:1	60	430	7.2
DGAB36	36:1	75	800	10.7
DGAB41	41:1	110	1350	12.3
DGAB47	47:1	160	2000	12.5

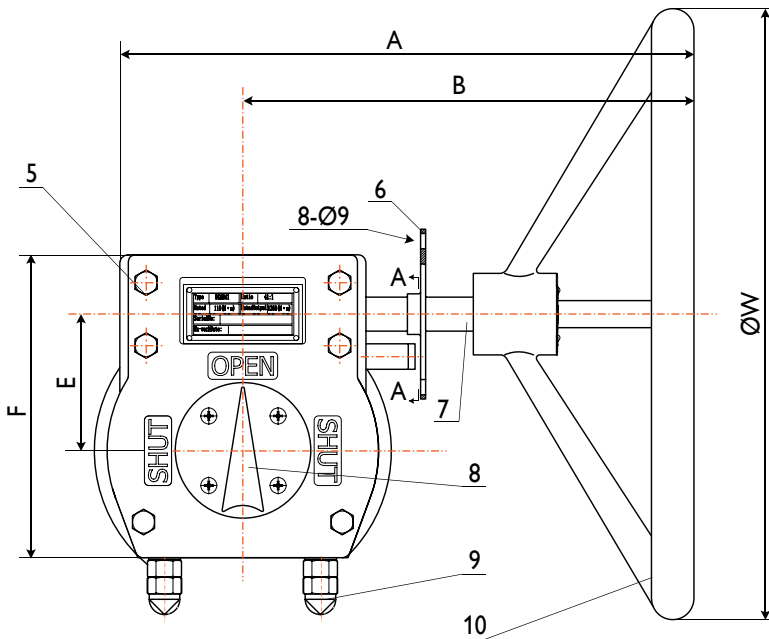

TOP VIEW

A-A

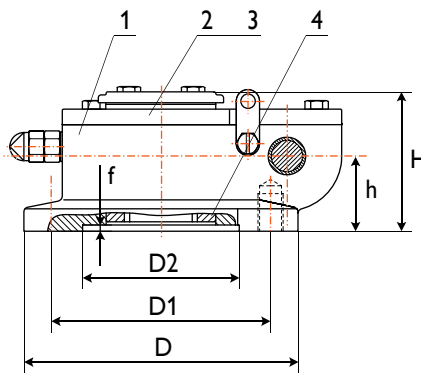
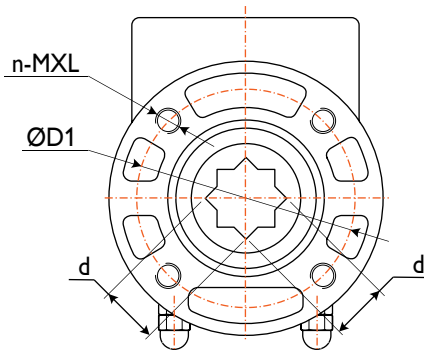

DIMENSIONS (MM)

Model	D	D1	D2	f	n-MXL	d	A	B	E	F	H	h	W	Weight (kg)
DGAB24 F07 14	90	70	55	3	4-M8X12	14	256	211	44.5	116	67	31	250	4.5
DGAB24 F10 17	125	102	70	3	4-M10X15	17								
DGAB24 F10 22	125	102	70	3	4-M10X15	22								
DGAB36 F12 27	150	125	85	3	4-M12X18	27	273	218	61.5	138	80	41	320	6.5
DGAB41 F12 27	175	125	85	3	4-M12X18	27	338	266	80.5	179	90	48	360	11.5
DGAB47 F12 27	175	125	85	3	4-M12X18	27	338	266	89.5	185	95	54	460	12.5
DGAB36 F10 22	125	102	70	3	4-M10X15	22	273	220	61.5	138	80	41	320	6.5
DGAB41 F14 36	175	140	100	4	4-M16X24	36	338	266	80.5	179	90	54	320	11.5
DGAB47 F14 36	175	140	100	4	4-M16X24	36	338	266	89.5	185	95	54	320	12.5
DGAB47 F14 36	175	140	100	4	4-M16X24	36	410	340						12.7

MOS SERIES DECLUTCHABLE GEAR OVERRIDE

HEAVY DUTY QUARTER TURN WORM TYPE GEAR OVER-RIDE

FEATURES

- Compact and light weight
- There are two keyway 90° apart to allow mounting east-west or north-south.
- Pull out the positioning pin & rotate the off-centre device 180° to engage the gearbox, disengage the opposite way.
- The gear operator is filled with a special lubricant. The gearbox is a sealed unit and is dust proof & waterproof and made to IP65.
- The bottom of gear operator should be connected to the valve (bracket mounting), the top is connected to the actuator with the valve stem going through the inner hole of worm gear and the square on the end of stem then inserts into the square hole of the actuator cylinder.
- The unit can be switched between manual gear & automatic actuator operation but does not allow engagement of both devices at the same time. The cylinder of the gear operator engages to the valve stem & disengages the actuator in one position, then in the other position this is reversed.

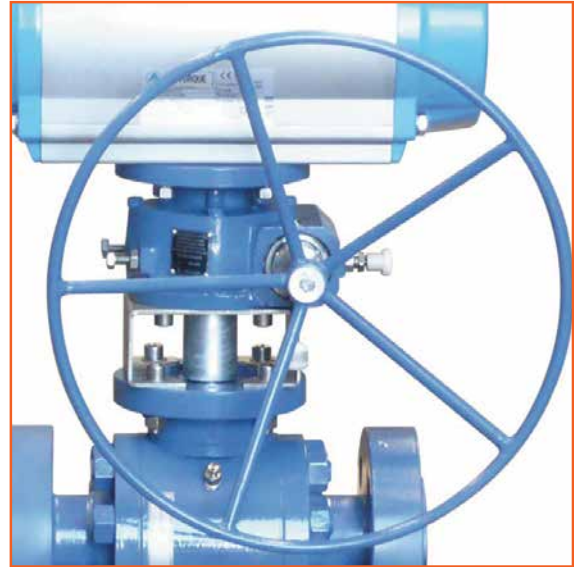

APPLICABLE STANDARDS

Model MOS-1 / MOS-2 / MOS-3 / MOS-4 / MOS-5 / MOS-7 / MOS-8
Torque Range 100 to 9800 Nm
Temperature -20°C to +80°C
Stroke Adjustment ±10
Movement 0° to 90°

MO Series manual override is an emergency device for the opening and closing of a valve in case of a pneumatic actuator failure. It's self-locking worm gear design provides safe & easy operation for transferring between control & manual operation.

The MO Series declutchable gear operators provide an easy and reliable method of direct manual operation that can be utilised to over-ride the actuator as emergency control on air failure, or as a local control in the event of controller malfunction. When the hand wheel is clutched in, the valve is then under local manual control and the remote control is 'locked out'.

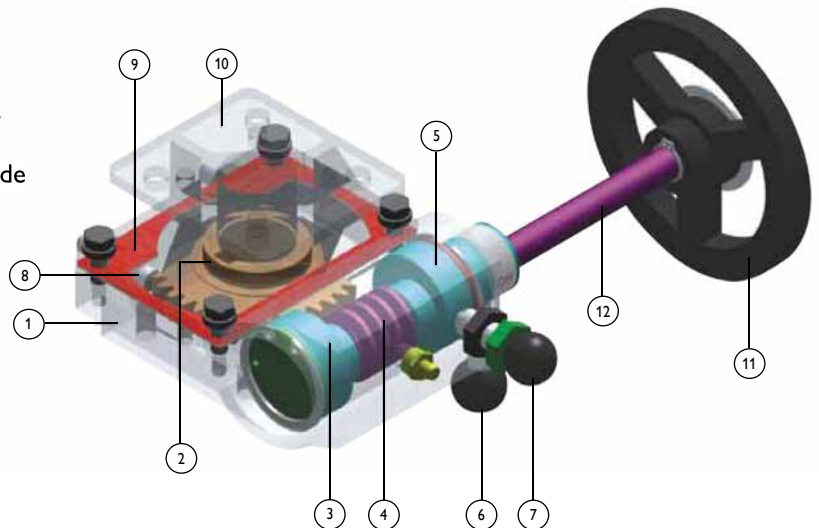

MATERIALS

No.	Part Name	Material
1	Housing	Aluminium / Ductile Iron
2	Worm Wheel	SGI 600
3	Eccentric Bush Bear	EN8 Alloy Steel + ZP
4	Worm Shaft	EN8 Alloy Steel + ZP
5	Eccentric Bush H/W Side	EN8 Alloy Steel + ZP
6	Selector	Steel

No.	Part Name	Material
7	On/Off Lever	EN8 ZP Alloy Steel
8	Limit Stop	EN8 ZP Alloy Steel
9	Gasket	CNAF / Viton
10	Top Cover	Aluminium / Ductile Iron
11	Hand Wheel	Aluminium
12	Stem	EN8 Alloy Steel + ENP



AUSTRALIAN PIPELINE VALVE®

COMPLETE PRODUCT LINE

“Australian Pipeline Valve produces isolation, control and flow reversal protection products for severe and critical service media in utility, steam, pipelines, oil & gas and process industries. APV valves and pipeline products form the most competitive portfolio in the market.”



SUPER-CHECK®



TORQTURN®

TWIN-LOK®

UNIFLO®



AUSTRALIAN PIPELINE VALVE BRAND RANGE - CATALOGUES

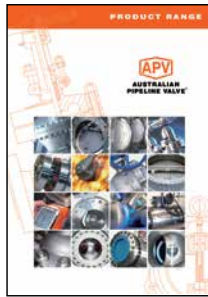

Product Brochure



Ball Valves Floating & Trunnion Mounted

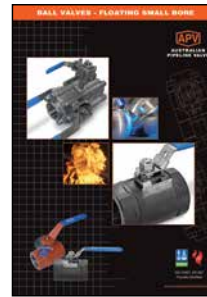

Ball Valves Floating Small Bore

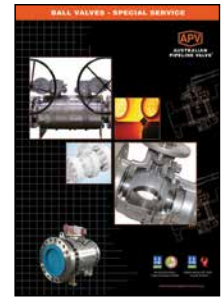

Ball Valves Special Service



Gate, Globe & Check Valves - Cast Steel



Gate, Globe & Check Valves - Forged Steel

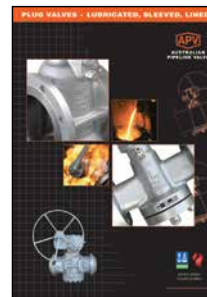

Plug Valves Lubricated, Sleeved & Lined

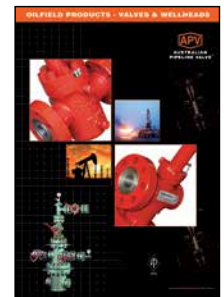

Oilfield Products - Valves & Wellheads

APV FAMILY OF BRANDS RANGE - CATALOGUES



Diamond Gear Gearboxes



Flowturn Ball Valves Multiway & Deadman



Flowturn Gate, Globe & Check Valves



Flowturn Instrument Valves

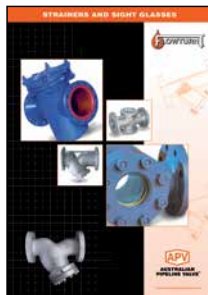

Flowturn Strainers & Sight Glasses



Steamco Steam Valves



Supercheck Wafer Check Valves



Superseal Butterfly Valves

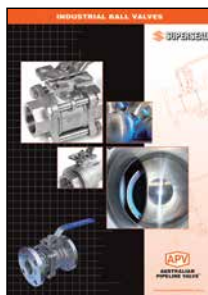

Superseal Industrial Ball Valves



Torqturn Actuators

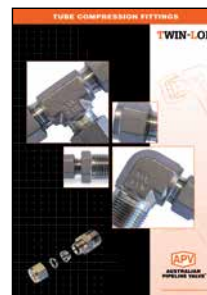

TwinLok Tube Fittings

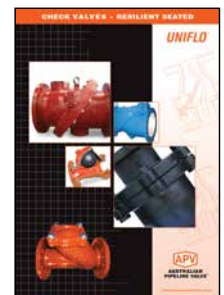

Uniflo Check Valves

Contact us for your local stockist/distributor



AUSTRALIAN PIPELINE VALVE®

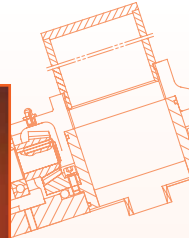
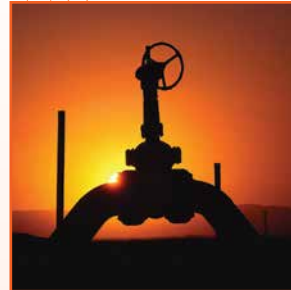

www.australianpipelinevalve.com.au

LOCAL DISTRIBUTOR

Global Supply Line is distributor & stockist, supplying worldwide.
Full stock list on line www.globalsupplyline.com.au

Contact email: sales@globalsupplyline.com.au

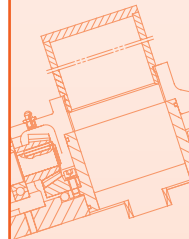

We have endeavoured to provide a broad outline of our range and capabilities. Because we are continually developing new products for our customers this catalogue will, to some extent be incomplete. This catalogue is a general overview only, individual drawings and data sheets can be furnished on request.

If you have any requirement in the field of valves and accessories, please contact us for a prompt response. Continuous development of Australian Pipeline Valve products may necessitate changes in the design or manufacturing processes. Australian Pipeline Valve reserves the right to effect any such changes without prior notice.

