



# GALLI & CASSINA

*Plus Valves*

SINCE 1919



## LUBRICATED



## PLUG

## VALVES

## STANDARD & FULL

## JACKETED

## TYPE





## Galli&Cassina Profile



**Galli&Cassina** is a prominent Italian Company, leader in Design and manufacturing a complete range of Lubricated Plug valves.

The company is located in Solaro near to Milan (Italy)

**Galli&Cassina** was founded in 1919, and it is one of the oldest Italian companies which today is still in the valve business; in the beginnings G&C business activity was concentrated in the production of valves to serve the domestic growing market.

After the first ten years the company gradually turned its production towards the newly born Chemical Industry.

**G&C** was the first in Italy to produce valves in stainless steel and other special material in light with the demand

of the most important chemical companies.

It was not possible to expand further the Milan factory which was built in 1930 and enlarged after the second world war, for this reason in 1991 **Galli&Cassina** has moved to a new location in Solaro (Milan) with modern building and facilities.

After 30 years of experience in chemical valves, **Galli&Cassina** started the production of Plug Valves to serve the Oil & Gas worldwide market becoming one of the most significant supplier for all



with extensive offices and workshop covering 12.000 sq.mt. area including 5000 sq.mt. of covered space.





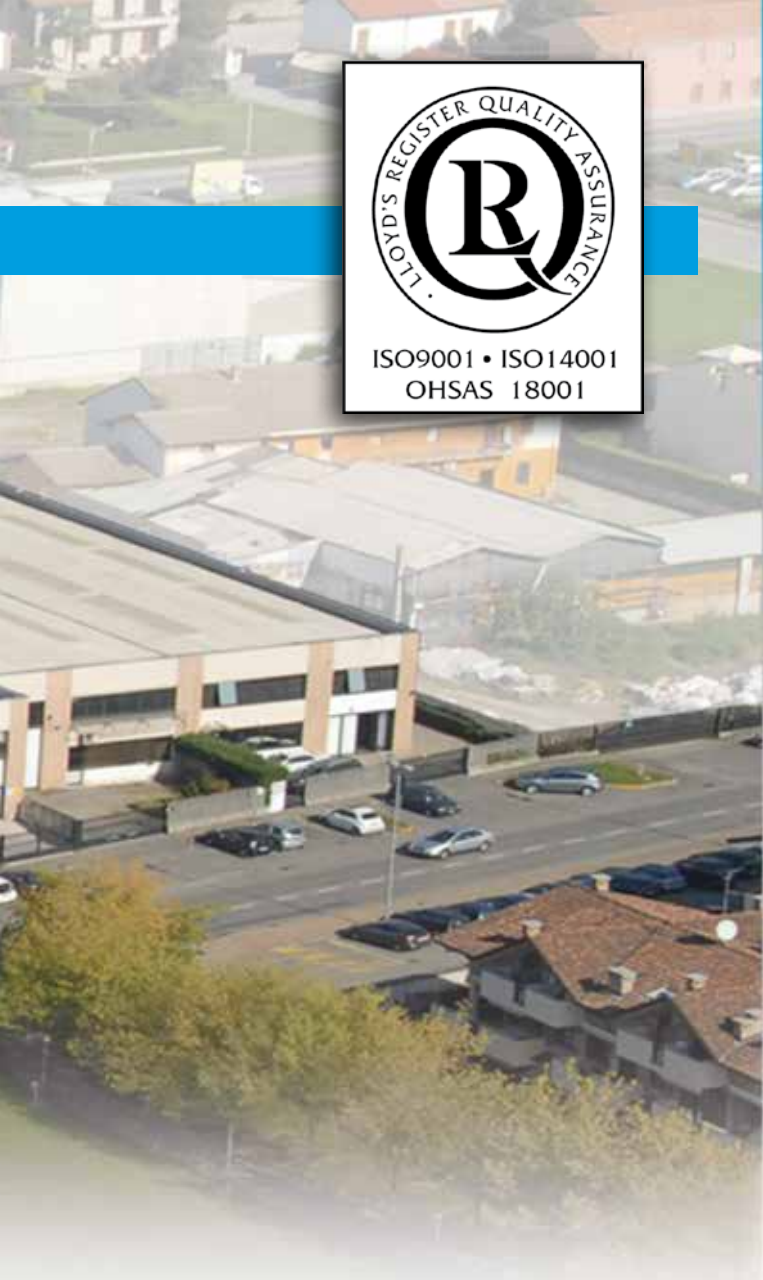

**1. WORKSHOP & OFFICES.**



**2. WELDING.**



**3. MATERIAL RECEIVING.**



**4. TESTING AND INSPECTION.**



**5. PACKING AND SHIPPING.**



**6. WAREHOUSE.**

*International Oil & Gas companies across the world.*

*Its sales activity covers most of the continents with a leading and growing presence in Europe, Middle East, North & South America and Far East resulting in a sales and service network with subsidiaries, branch offices and distributors, achieving the reputation of high quality and reliable product.*

*Galli&Cassina pays a particular attention to company development in every area, to be in line with the continuous market evolution.*

*The proved technical, production, and financial*

*capabilities combined with experience of human resources are the result of Galli&Cassina reputation all over in the world.*

*Galli&Cassina's Quality Assurance System & HSE according to ISO 9001-2008, ISO 14001 & ISO 18001 have been assessed, approved and certified by Lloyd's Register, while the API 6D and 6A monogram have been certified by API*

*(American Petroleum Institute) - Washington U.S.A. Nowadays Galli&Cassina is*

*proud to celebrate its 95 years presence in the world valves market.*







# Galli&Cassina Profile



1

2

3

4

6

5



# Index



## **Section 1**

**Page 8**

Two Way Standard Type  
ANSI 125-150-300 Lb.  
DIN PN 16-40.

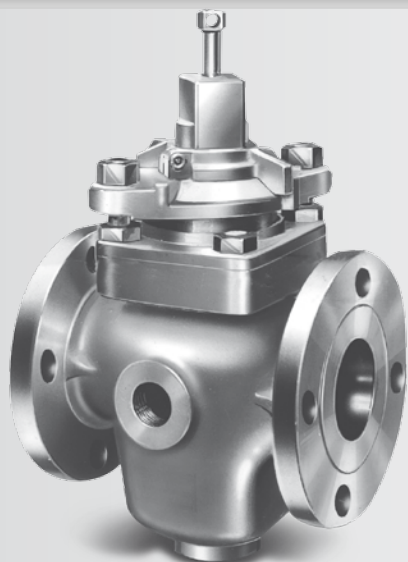

## **Section 2**

**Page 20**

Two Way Jacketed  
ANSI 150-300 Lb.

Two Way Full Jacketed  
ANSI 150-300 Lb.

DIN PN 16-40 (Flanges only)



## **Section 3**

**Page 32**

Multiport Three-Four Way  
ANSI 150-300 Lb.  
DIN PN 16-40 (Flanges only)  
(Transflow/Non Transflow Pattern).

Multiport Three-Four Way  
Jacketed  
Full Jacketed  
ANSI 150 Lb.  
DIN PN 16-40 (Flanges only)



# Index

| Class  |                           |           |    |           | Page N. | Figure                    |
|--|---------------------------|-----------|----|-----------|---------|---------------------------|
| <b>Section 1 Two Way Plug Valves Standard Type</b> |                           |           |    |           |         |                           |
| ANSI 125   | Short Pattern             | 1"        | to | 8"        | 10      | SCC - X1R                 |
| ANSI 125   | Short Pattern             | 6"        | to | 12"       | 11      | SCR - X1R                 |
| ANSI 125   | Regular Pattern           | 1/2"      | to | 8"        | 12      | SRC - X1T/RC - 1R         |
| ANSI 125   | Regular / Venturi Pattern | 6"        | to | 12"       | 13      | SRR - X1R/VR - 1R         |
| ANSI 150   | Short Pattern             | 1"        | to | 8"        | 14      | SCC - 01F/SCC - 01R       |
| ANSI 150   | Short Pattern             | 6"        | to | 12"       | 15      | SCR - 01R                 |
| ANSI 150   | Regular Pattern           | 1"        | to | 8"        | 16      | SRC - 01F/SRC - 01R       |
| ANSI 150   | Regular / Venturi Pattern | 6"        | to | 12"       | 17      | SRR - 01R/SVR - 01R       |
| ANSI 300   | Short Pattern             | 1/2"      | to | 6"        | 18      | SCC - 03F/SCC - 03R       |
| ANSI 300   | Short Pattern             | 5"        | to | 12"       | 19      | SCR - 03R                 |
| <b>Section 2 Two Way Jacketed</b>                  |                           |           |    |           |         |                           |
| ANSI 150   | Short Pattern             | 2"        | to | 6"        | 21      | VCC - 01R                 |
| ANSI 150   | Short Pattern             | 6"        | to | 12"       | 22      | VCR - 01R                 |
| ANSI 150   | Regular Pattern           | 1 1/2"    | to | 6"        | 23      | VRC - 01R/VRR - 01R       |
| ANSI 300   | Short Pattern             | 1 1/2"    | to | 6"        | 24      | VCC - 03R                 |
| ANSI 300   | Venturi Pattern           | 6"        | to | 12"       | 25      | VVR - 03R                 |
| <b>Two Way Full Jacketed</b>                       |                           |           |    |           |         |                           |
| ANSI 150   | Short Pattern             | 1" x 2"   | to | 8" x 10"  | 26      | ZRC - 01R                 |
| ANSI 150   | Regular Pattern           | 10" x 12" | to | 24" x 26" | 27      | ZRR - 01R                 |
| ANSI 300   | Regular Pattern           | 1" x 2"   | to | 8" x 10"  | 28      | ZRC - 03R                 |
| ANSI 300   | Regular Pattern           | 10" x 12" | to | 24" x 26" | 29      | ZRR - 03R                 |
| <b>Two Way Full Jacketed - Full Bore</b>           |                           |           |    |           |         |                           |
| ANSI 150   | Full Bore                 | 1" x 2"   | to | 10" x 12" | 30      | ZFC - 01R/ZFR - 01R       |
| ANSI 300   | Full Bore                 | 1" x 2"   | to | 10" x 12" | 31      | ZFC - 03R/ZFR - 03R       |
| <b>Section 3 Multiport Three-Four Way Valves</b>   |                           |           |    |           |         |                           |
| ANSI 150   | Long Pattern              | 1/2"      | to | 5"        | 32      | MCR - LRC - URC - 01T/01R |
| ANSI 150   | Long Pattern              | 4"        | to | 8"        | 34      | MRR - LRR - URR - 01T/01R |
| ANSI 300   | Long Pattern              | 1/2"      | to | 4"        | 35      | MRC - LRC - URC - 03T/03R |
| ANSI 300   | Long Pattern              | 4"        | to | 8"        | 36      | MRC - LRC - URC - 03T/03R |

## Engineering Data - page 39 to 40

**Note:** Galli&Cassina with the scope of improving continuously his products, reserve the right to change or modify without incurring in any obligation to provide or

install such modification on plug valves previously or subsequently sold.





# Patterns

**Galli & Cassina Plug Valves are available in four different patterns. The pattern indicates basic information about the valve in terms of end to end dimension (according to API 6D & BS 5353) and the size of the flow port through the valve.**

## Short Pattern

Short Pattern Valves have compact face to face dimensions (like a Gate Valve) and rectangular port areas of 40% to 60% of a Full Bore Plug valve. This provides an economical valve for services where some reduction of flow rates can be tolerated. The Short Pattern is only in classes 150 and 300.

## Venturi Pattern

Venturi Pattern Plug Valves also have a longer face to face but with a rectangular port areas of 40-50% of a Full Bore Plug valve. These are typically used on services where flow rate is not critical. The long lead into and out of the port minimises pressure drop when the valve is fully opened.

## Regular Pattern

Regular Pattern Plug Valves have a longer face to face dimensions and rectangular port areas of 50-70% of a Full Bore Plug valve. This configuration provides minimal loss of flow while economising on the overall valve dimensions.

## Full Bore

Full Bore Plug Valves have long face to face dimensions and a round port that is not smaller than specified in Annex A of ASME B 16.34 or/and API 6D. This configuration provides unrestricted flow and allows the passage of pigs and spheres through the valve. It is also preferred for highly abrasive conditions as it minimises pressure drop and erosion in the valve.

# Applicable-Standards-Specification

**Lubricated plug valves are designed to use with most refining services according to API 599 or BS 5353 norms whichever is applicable. API 6D norm aims to standardize the materials as well as instructions to manufacture valves suitable for energy transportation in the pipelines.**

|                   |   |                                   |  |
|-------------------|---|-----------------------------------|--|
| API 6D            | Specification for pipeline valves                     | BS 1504                           | Specification for steel casting for pressure purposes                  |
| API 6FA           | Specification for fire test for valves                | BS 2080                           | Face to face - Centre to face - End to end Steel valves                |
| API 598           | Valve inspection and testing                          | BS 5353                           | Specification for steel plug valves                                    |
| API 599           | Steel plug valves flanged or butt welding ends        | BS 6755 part 1                    | Testing of valves (Spec. for production pressure testing requirements) |
| ASME/ANSI B 16.5  | Pipe flanges and flanged fittings                     | BS 6755 part 2                    | Testing of valves (Spec. for fire safe - Testing requirements)         |
| ASME/ANSI B 16.10 | Face-to-face and end-to-end dimensions of valves      | CSA-Z 245-15                      | Canadian Std Association   |
| ASME/ANSI B 16.25 | Buttwelding ends                                      | MSS-SP6                           | Standard finish for contact face of pipe flanges                       |
| ASME/ANSI B 16.34 | Valves-flanged, threaded and welding ends             | MSS-SP25                          | Standard marking system for valves                                     |
| ASME/ANSI B 31.3  | Chemical plant and petroleum refinery piping          | MSS-SP44                          | Steel pipeline flanges   |
| ASME/ANSI B 31.4  | Liquid transportation system for liquid petroleum gas | MSS-SP55                          | Quality standard for steel casting visual method                       |
| ASME/ANSI B 31.8  | Gas transmission and distribution piping system       | MSS-SP61                          | Pressure Testing of Steel valves                                       |
| ANSI B 1.20.1     | Pipe - Threads  | MSS-SP78                          | Cast Iron Plug Valve Flanged and Threaded Ends                         |
| ASTM              | American society for testing and materials            | NACE Std. MR 01.75 Latest Edition | National association of corrosion engineers                            |



## Standard Type

**Standard type plug valves are made in accordance with the conventional bolted type gland valves, with extended operating stem integral with the longer side of the tapered plug.**

**In this type of valve, the plug is kept in the body by a bolted cover which centres the plug in the body avoiding the blowout of it, without the gland.**

**Gland function, is to keep the pressure on packing rings which prevents any possibility of leakage through the shank and at the same time it guarantees the weatherseal.**

**Furthermore, the pressure is transmitted to the plug through the shim, so the plug can maintain its correct position in the body.**

**Shim function, is to reduce the friction between the packing**

**rings with the longer side of the tapered plug, besides avoiding shank fluid infiltration.**

**The lubrication of the plug can be done any time when it is necessary to guarantee the tightness of the valve, even when the valve is in service.**

**The above operation shall be made simply by injecting lubricant through the lubricant screw, where a check valve prevents leakage of grease during injection.**

**From the internal sealant duct, the grease goes down through the grooves which then serve to lubricate the plug.**

**During valve rotation, open/close or reverse, each groove is insulated from the rest of lubricant system, thus avoiding any possibility of lubricant leakage into the line.**

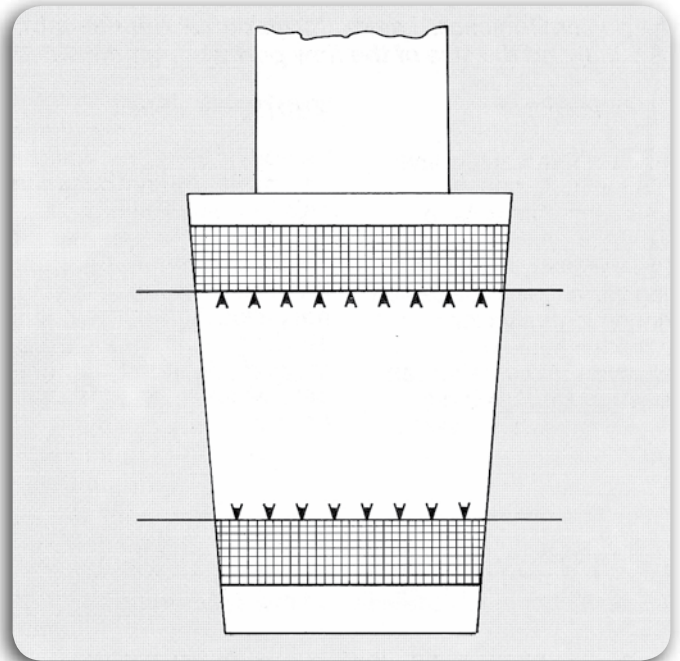

### Special Treatment

Special antifriction treatment with PTFE of the plug, provides at the same time the following advantages:

- Greatly improved wear resistance.
- Low friction between plug and body.
- Low torque moment and resistance to seizure.

## Fire Safe Test



**All Galli & Cassina's plug valves have been tested against fire resistance, according to API - 6FA and BS 6755 - Part. 2 standards and witnessed by international third party. Metal to Metal seating surfaces, as well as the stem sealing compound with graphite guarantee a high reliability performance of our plug valves while are in exposure to fire test conditions.**





## Section 1 - Two Way Standard Type - Design Features

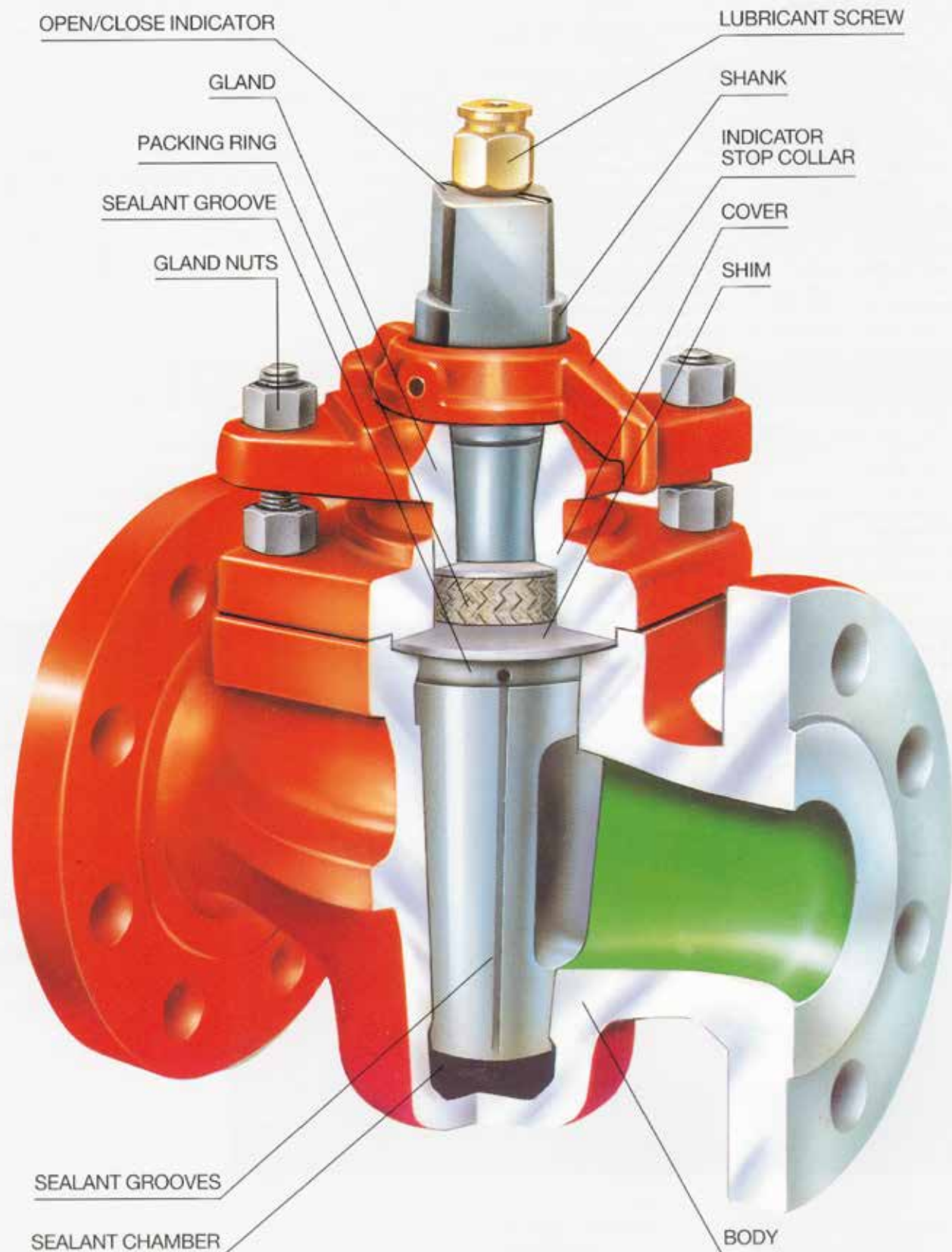

**NOTE:** Each valve with wrench operation, the plug open and closed position are assured by corresponding stop indicator fitted on bare stem. The open position of the valve has the stop indicator parallel to flow direction of the fluid.



# Material Selection Guide for GALLI&CASSINA Valves

In the table shown below there are designated N. 3 categories of trim materials, suitable for many different service conditions.

1. Standard Carbon Steel Body and Plug - API 6D. (ASTM-A105-A216 WCB/WCC material) suitable for general services.
2. Carbon Steel Body and Plug (A352 LCB/LCC material) suitable for low temperature services.

3. Carbon Steel Body and Plug (ASTM A216WCB/WCC material) suitable for "SOUR SERVICE" (H<sub>2</sub>S and CO<sub>2</sub>) according to NACE-MR.01.75/Latest Edition.

**Note:** Other material upon request.

## Standard design categories (Typical construction materials)

| Trim Service   | Class      | • Body<br>• Cover   | Plug / Stem   | Bolting  |
|--|------------|---|---|--|
| <b>1 Standard service</b><br>Natural gas<br>Hydrocarbons                         | 150 to 300 | ASTM A105<br>ASTM A216<br>WCB/WCC   | ASTM A105<br>ASTM A216<br>WCB/WCC<br>PTFE Treatment                         | ASTM A193-B7<br>ASTM A194-2H                               |
| <b>2 Low temperature</b><br>Natural gas<br>Hydrocarbons                          | 150 to 300 | ASTM A350-LF2<br>ASTM A352<br>LCB/LCC<br>Max C 0.23%                        | ASTM A350-LF2<br>ASTM A352-<br>LCB/LCC<br>PTFE Treatment                    | ASTM A320-L7<br>ASTM A194 Gr.7                             |
| <b>3 Sour Service</b><br>(H <sub>2</sub> S and CO <sub>2</sub> )<br>Hydrocarbons | 150 to 300 | ASTM A105<br>Max 187 HB<br>ASTM-A216 WCB/WCC<br>Max 22HRC<br>PTFE Treatment | ASTM A105<br>Max 187 HB<br>ASTM-A216 WCB/WCC<br>Max 22HRC<br>PTFE Treatment | ASTM A193-B7M<br>ASTM A194-2HM<br>PTFE Treatment<br>237 HB |





# ANSI Class 125 (PN 10)

(Cast Iron Body and Plug) ASTM - A - 126 - Gr.B

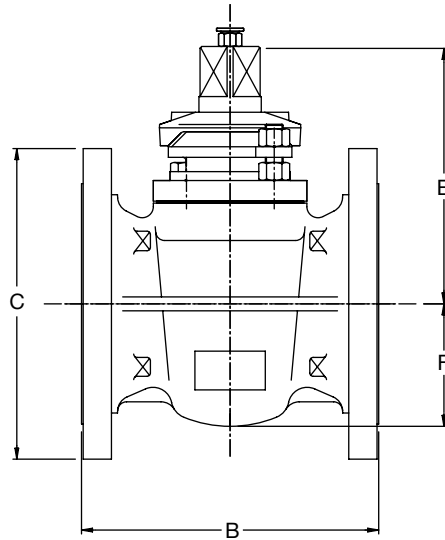

SCC X1R - Short with Wrench

| Size  | NPS<br>DN | Short Pattern |          |         |          |         |          |          |          |          |      |
|---|-----------|---------------|----------|---------|----------|---------|----------|----------|----------|----------|------|
|   |           | 1<br>25       | 1½<br>40 | 2<br>50 | 2½<br>65 | 3<br>80 | 4<br>100 | 5<br>125 | 6<br>150 | 8<br>200 |      |
| FACE TO FACE                                  | <b>B</b>  | mm            | 140      | 165     | 178      | 191     | 203      | 229      | 254      | 267      | 292  |
| FLANGE DIAMETER<br>ANSI 125 FF                | <b>C</b>  | mm            | 108      | 127     | 152      | 178     | 191      | 229      | 254      | 279      | 343  |
| N. TAPPED HOLES<br>UNC THREADED<br>IN FLANGES |           |               | -        | -       | -        | -       | -        | -        | 2        | 2        | 2    |
| CENTER LINE<br>TO TOP OF STEM                 | <b>E</b>  | mm            | 107      | 136     | 152      | 176     | 207      | 230      | 245      | 300      | 330  |
| CENTER LINE<br>TO BOTTOM OF BODY              | <b>F</b>  | mm            | 42       | 62      | 67       | 76      | 100      | 110      | 130      | 160      | 180  |
| WEIGHT  |           | kg            | 6        | 11      | 13       | 19      | 25       | 38       | 60       | 78       | 100  |
| WRENCH - LENGHT                               |           | mm            | 235      | 320     | 320      | 400     | 500      | 570      | 720      | 1010     | 1230 |



# ANSI Class 125 (PN 10)

(Cast Iron Body and Plug) ASTM - A - 126 - Gr.B

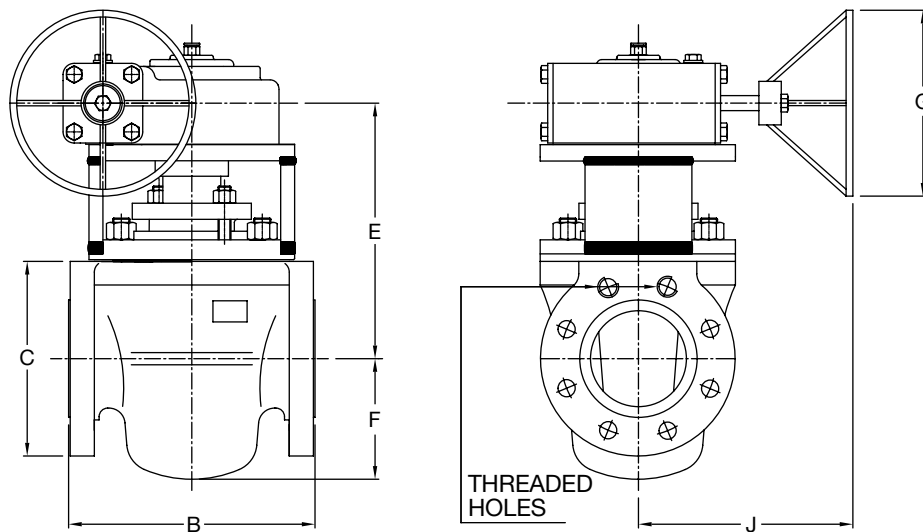

SCR - X1R - Short with Gear

| Size   | NPS<br>DN | Short Pattern |          |           |           |     |
|--|-----------|---------------|----------|-----------|-----------|-----|
|  |           | 6<br>150      | 8<br>200 | 10<br>250 | 12<br>300 |     |
| FACE TO FACE                                     | <b>B</b>  | mm            | 267      | 292       | 330       | 356 |
| FLANGE DIAMETER<br>ANSI 125 FF                   | <b>C</b>  | mm            | 279      | 343       | 406       | 483 |
| N. TAPPED HOLES<br>UNC THREADED<br>IN FLANGES    |           |               | 2        | 2         | 2         | 4   |
| CENTER LINE TO CENTER<br>OF HANDWHEEL            | <b>E</b>  | mm            | 570      | 600       | 660       | 700 |
| CENTER LINE<br>TO BOTTOM OF BODY                 | <b>F</b>  | mm            | 160      | 180       | 220       | 286 |
| HANDWHEEL<br>DIAMETER                            | <b>G</b>  | mm            | 560      | 560       | 560       | 560 |
| LONGITUDINAL<br>CENTER LINE<br>TO FACE HANDWHEEL | <b>J</b>  | mm            | 330      | 330       | 450       | 450 |
| WEIGHT   |           | kg            | 115      | 140       | 180       | 280 |





# ANSI Class 125 (PN 10)

(Cast Iron Body and Plug) ASTM - A - 126 - Gr.B

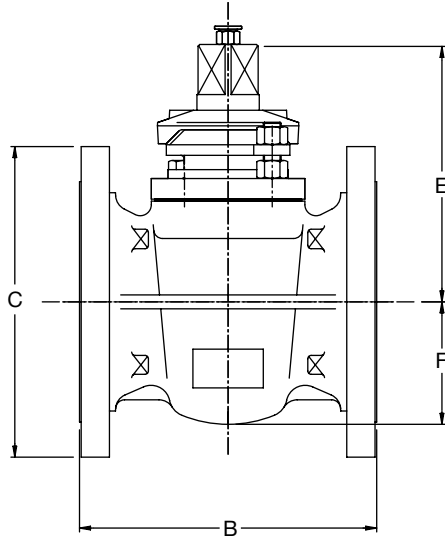

**SRC X1R - Regular with Wrench**

| Size                             | NPS<br>DN | Regular Pattern |           |         |             |             |         |             |         |          |          |          |          |      |
|----------------------------------|-----------|-----------------|-----------|---------|-------------|-------------|---------|-------------|---------|----------|----------|----------|----------|------|
|                                  |           | 1/2<br>15       | 3/4<br>20 | 1<br>25 | 1 1/4<br>32 | 1 1/2<br>40 | 2<br>50 | 2 1/2<br>65 | 3<br>80 | 4<br>100 | 5<br>125 | 6<br>150 | 8<br>200 |      |
| END TO END<br>THREADED           | <b>A</b>  | mm              | 90        | 95      | 110         | 130         | 135     | 150         | 175     | 200      | 275      | -        | -        | -    |
| FACE TO FACE                     | <b>B</b>  | mm              | 110       | 120     | 140         | 150         | 165     | 200         | 220     | 240      | 305      | 356      | 394      | 457  |
| FLANGE DIAMETER<br>ANSI 125 FF   | <b>C</b>  | mm              | -         | -       | 108         | 117         | 127     | 152         | 178     | 191      | 229      | 254      | 279      | 343  |
| CENTER LINE<br>TO TOP OF STEM    | <b>E</b>  | mm              | 92        | 115     | 120         | 140         | 152     | 176         | 207     | 230      | 245      | 296      | 330      | 410  |
| CENTER LINE<br>TO BOTTOM OF BODY | <b>F</b>  | mm              | 35        | 46      | 50          | 60          | 65      | 76          | 93      | 108      | 130      | 155      | 185      | 230  |
| WEIGHT THREADED<br>ENDS          |           | kg              | 1,7       | 3       | 4           | 6           | 7       | 12          | 16      | 24       | 41       | -        | -        | -    |
| WEIGHT FLANGED                   |           | kg              | 3         | 4       | 6           | 8           | 10      | 14          | 20      | 27       | 40       | 62       | 80       | 110  |
| WRENCH - LENGHT                  |           | mm              | 235       | 235     | 235         | 320         | 320     | 400         | 500     | 570      | 720      | 1010     | 1010     | 1230 |



# ANSI Class 125 (PN 10)

(Cast Iron Body and Plug) ASTM - A - 126 - Gr.B

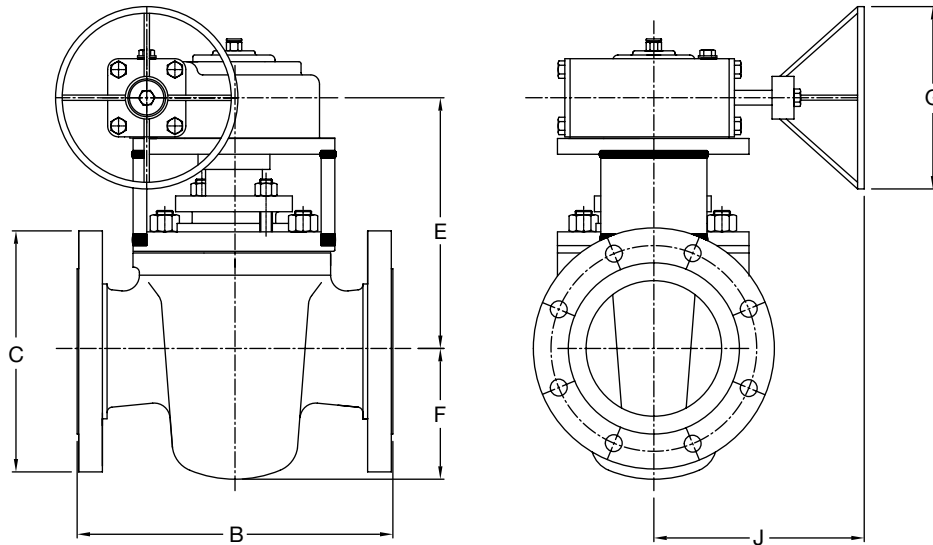

**SRR X1R - Regular with Gear**  
**SVR X1R - Venturi with Gear**

| Size  | NPS<br>DN   | Regular Pattern |          | Venturi Pattern |           |
|---|-------------|-----------------|----------|-----------------|-----------|
|   |             | 6<br>150        | 8<br>200 | 10<br>250       | 12<br>300 |
| FACE TO FACE  | <b>B</b> mm | 394             | 457      | 533             | 610       |
| FLANGE DIAMETER<br>ANSI 125 FF                      | <b>C</b> mm | 279             | 343      | 406             | 483       |
| CENTER LINE TO CENTER<br>OF HANDWHEEL               | <b>E</b> mm | 585             | 690      | 770             | 810       |
| CENTER LINE<br>TO BOTTOM OF BODY                    | <b>F</b> mm | 185             | 230      | 290             | 330       |
| DIAMETER  | <b>G</b> mm | 560             | 560      | 560             | 560       |
| LONGITUDINAL<br>CENTER LINE TO<br>FACE TO HANDWHEEL | <b>J</b> mm | 330             | 330      | 450             | 450       |
| WEIGHT  | kg          | 115             | 146      | 210             | 290       |





# ANSI Class 150 (PN 20)

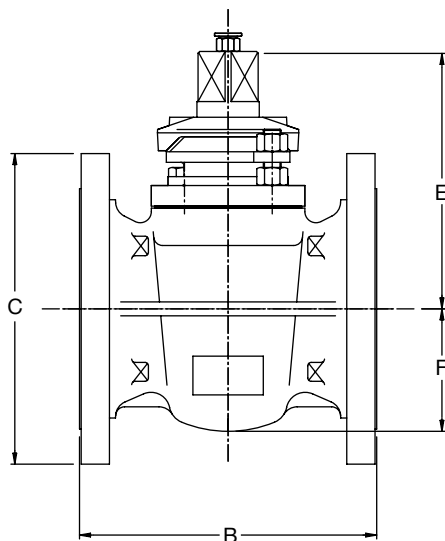

**SCC X1R - Short with Wrench**

| Size  | NPS<br>DN   | Short Pattern |          |         |          |         |          |          |          |          |
|---|-------------|---------------|----------|---------|----------|---------|----------|----------|----------|----------|
|   |             | 1<br>25       | 1½<br>40 | 2<br>50 | 2½<br>65 | 3<br>80 | 4<br>100 | 5<br>125 | 6<br>150 | 8<br>200 |
| END TO END<br>THREADED                        | <b>A</b> mm | -             | -        | 150     | 170      | 180     | 210      | -        | -        | -        |
| FACE TO FACE                                  | <b>B</b> mm | 140           | 165      | 178     | 191      | 203     | 229      | 254      | 267      | 292      |
| FLANGE DIAMETER<br>ANSI 150 RF                | <b>C</b> mm | 108           | 127      | 152     | 178      | 191     | 229      | 254      | 279      | 343      |
| N. TAPPED HOLES<br>UNC THREADED<br>IN FLANGES |             | -             | -        | -       | -        | -       | -        | 2        | 2        | 2        |
| CENTER LINE<br>TO TOP OF STEM                 | <b>E</b> mm | 107           | 136      | 152     | 176      | 207     | 230      | 245      | 300      | 330      |
| CENTER LINE<br>TO BOTTOM OF BODY              | <b>F</b> mm | 42            | 62       | 67      | 76       | 100     | 110      | 130      | 160      | 180      |
| WEIGHT THREADED<br>ENDS                       | kg          | -             | -        | 9       | 15       | 21      | 31       | -        | -        | -        |
| WEIGHT FLANGED                                | kg          | 6             | 10       | 14      | 20       | 27      | 40       | 62       | 80       | 110      |
| WRENCH - LENGHT                               | mm          | 235           | 320      | 320     | 400      | 500     | 570      | 720      | 1010     | 1230     |



# ANSI Class 150 (PN 20)

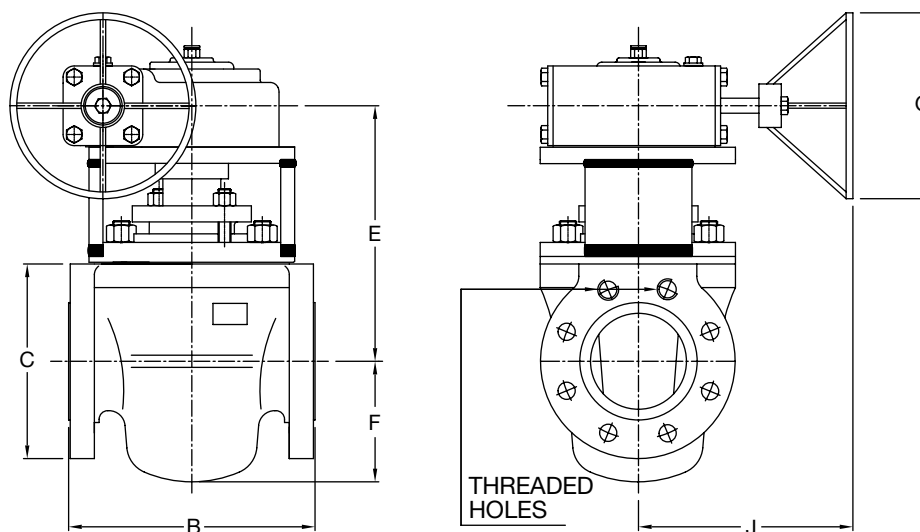

**SCR 01R - Short with Gear**

| Size  | Short Pattern |          |          |           |           |
|---|---------------|----------|----------|-----------|-----------|
|   | NPS<br>DN     | 6<br>150 | 8<br>200 | 10<br>250 | 12<br>300 |
| FACE TO FACE  | <b>B</b> mm   | 267      | 292      | 330       | 356       |
| FLANGE DIAMETER<br>DIN PN 16                        | <b>C</b> mm   | 285      | 340      | 405       | 460       |
| FLANGE DIAMETER<br>ANSI 150                         | <b>C</b> mm   | 279      | 343      | 406       | 483       |
| N. TAPPED HOLES<br>UNC THREADED<br>IN FLANGES       |               | 2        | 2        | 2         | 4         |
| CENTER LINE TO CENTER<br>OF HANDWHEEL               | <b>E</b> mm   | 570      | 600      | 630       | 690       |
| CENTER LINE<br>TO BOTTOM OF BODY                    | <b>F</b> mm   | 160      | 180      | 220       | 286       |
| HANDWHEEL<br>DIAMETER                               | <b>G</b> mm   | 560      | 560      | 560       | 560       |
| LONGITUDINAL<br>CENTER LINE TO<br>FACE OF HANDWHEEL | <b>J</b> mm   | 330      | 330      | 450       | 450       |
| WEIGHT  | kg            | 115      | 146      | 210       | 270       |





# ANSI Class 150 (PN 20)

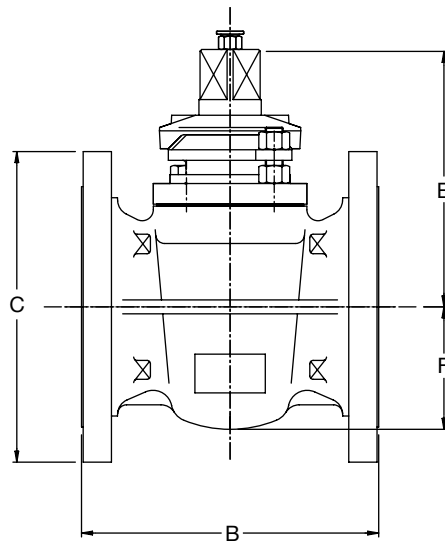

**SRC X1R - Regular with Wrench**

| Size                             | NPS<br>DN   | Regular Pattern |          |          |         |          |         |          |          |          |          |
|----------------------------------|-------------|-----------------|----------|----------|---------|----------|---------|----------|----------|----------|----------|
|                                  |             | 1<br>25         | 1¼<br>32 | 1½<br>40 | 2<br>50 | 2½<br>65 | 3<br>80 | 4<br>100 | 5<br>125 | 6<br>150 | 8<br>200 |
| END TO END<br>THREADED           | <b>A</b> mm | 110             | 130      | 135      | 165     | 190      | 205     | 275      | -        | -        | -        |
| FACE TO FACE                     | <b>B</b> mm | 140             | 150      | 165      | 200     | 220      | 240     | 300      | 350      | 394      | 457      |
| FLANGE DIAMETER<br>DIN PN 16     | <b>C</b> mm | 115             | 140      | 150      | 165     | 185      | 200     | 220      | 250      | 285      | 340      |
| FLANGE DIAMETER<br>ANSI 150      | <b>C</b> mm | 108             | 117      | 127      | 152     | 178      | 191     | 229      | 254      | 279      | 343      |
| CENTER LINE<br>TO TOP OF STEM    | <b>E</b> mm | 120             | 140      | 152      | 176     | 207      | 230     | 245      | 296      | 330      | 410      |
| CENTER LINE<br>TO BOTTOM OF BODY | <b>F</b> mm | 42              | 60       | 65       | 80      | 102      | 114     | 133      | 156      | 185      | 230      |
| WEIGHT THREADED ENDS             | kg          | 3,4             | 7        | 8        | 14      | 18       | 26      | 51       | -        | -        | -        |
| WEIGHT FLANGED                   | kg          | 6               | 9        | 11       | 19      | 27       | 31      | 55       | 74       | 107      | 175      |
| WRENCH - LENGHT                  | mm          | 235             | 320      | 320      | 400     | 500      | 570     | 720      | 1010     | 1010     | 1230     |



# ANSI Class 150 (PN 20)

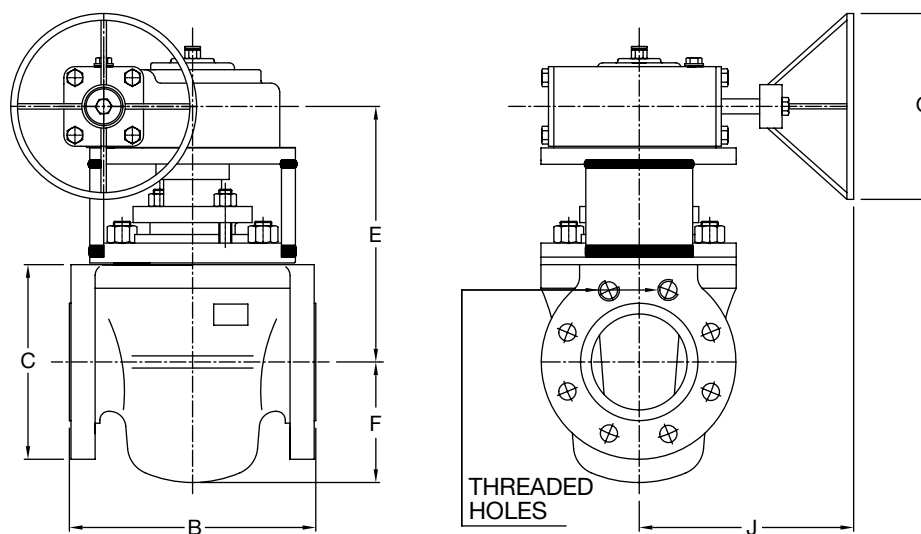

**SRR 01R - Regular with Gear**  
**SVR 01R - Venturi with Gear**

| Size  | NPS<br>DN | Regular Pattern |          |           | Venturi Pattern |     |
|---|-----------|-----------------|----------|-----------|-----------------|-----|
|   |           | 6<br>150        | 8<br>200 | 10<br>250 | 12<br>300       |     |
| FACE TO FACE  | <b>B</b>  | mm              | 394      | 457       | 533             | 610 |
| FLANGE DIAMETER<br>DIN PN 16                        | <b>C</b>  | mm              | 285      | 340       | 405             | 460 |
| FLANGE DIAMETER<br>ANSI 150                         | <b>C</b>  | mm              | 279      | 343       | 406             | 483 |
| CENTER LINE TO TOP<br>OF HANDWHEEL                  | <b>E</b>  | mm              | 585      | 690       | 770             | 810 |
| CENTER LINE<br>TO BOTTOM OF BODY                    | <b>F</b>  | mm              | 185      | 230       | 290             | 330 |
| HANDWHEEL<br>DIAMETER                               | <b>G</b>  | mm              | 560      | 560       | 560             | 560 |
| LONGITUDINAL<br>CENTER LINE TO<br>FACE OF HANDWHEEL | <b>J</b>  | mm              | 330      | 330       | 450             | 450 |
| WEIGHT  |           | kg              | 135      | 215       | 240             | 280 |



# ANSI Class 300 (PN 50)

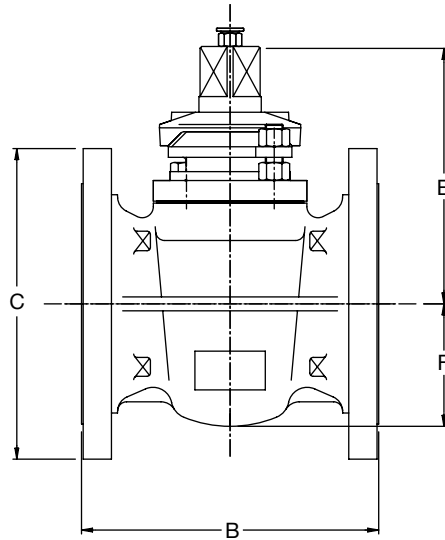

**SCC X1R - Short with Wrench**

| Size                             | NPS<br>DN   | Short Pattern |           |         |             |             |         |             |         |          |          |          |
|----------------------------------|-------------|---------------|-----------|---------|-------------|-------------|---------|-------------|---------|----------|----------|----------|
|                                  |             | 1/2<br>15     | 3/4<br>20 | 1<br>25 | 1 1/4<br>32 | 1 1/2<br>40 | 2<br>50 | 2 1/2<br>65 | 3<br>80 | 4<br>100 | 5<br>125 | 6<br>150 |
| END TO END<br>THREADED           | <b>A</b> mm | 90            | 95        | 110     | 130         | 135         | 165     | 190         | 205     | 275      | -        | -        |
| FACE TO FACE                     | <b>B</b> mm | 130           | 150       | 159     | -           | 190         | 216     | 241         | 283     | 305      | -        | 403      |
| FLANGE DIAMETER<br>DIN PN 40     | <b>C</b> mm | 95            | 105       | 115     | 140         | 150         | 165     | 185         | 200     | 235      | 270      | 300      |
| FLANGE DIAMETER<br>ANSI 300 RF   | <b>C</b> mm | 95            | 117       | 124     | -           | 156         | 165     | 191         | 210     | 254      | 279      | 318      |
| CENTER LINE<br>TO TOP OF STEM    | <b>E</b> mm | 92            | 115       | 120     | 140         | 152         | 176     | 207         | 230     | 245      | 296      | 300      |
| CENTER LINE<br>TO BOTTOM OF BODY | <b>F</b> mm | 30            | 38        | 42      | 60          | 68          | 80      | 102         | 114     | 133      | 155      | 160      |
| WEIGHT THREADED ENDS             | kg          | 1,8           | 3         | 3,4     | 7           | 8           | 14      | 18          | 26      | 51       | -        | -        |
| WEIGHT FLANGED                   | kg          | 3             | 4,5       | 6,5     | 10          | 13          | 20      | 30          | 38      | 69       | 95       | 130      |
| WRENCH - LENGHT                  | mm          | 235           | 235       | 235     | 320         | 320         | 400     | 500         | 570     | 720      | 1010     | 1010     |





# ANSI Class 300 (PN 50)

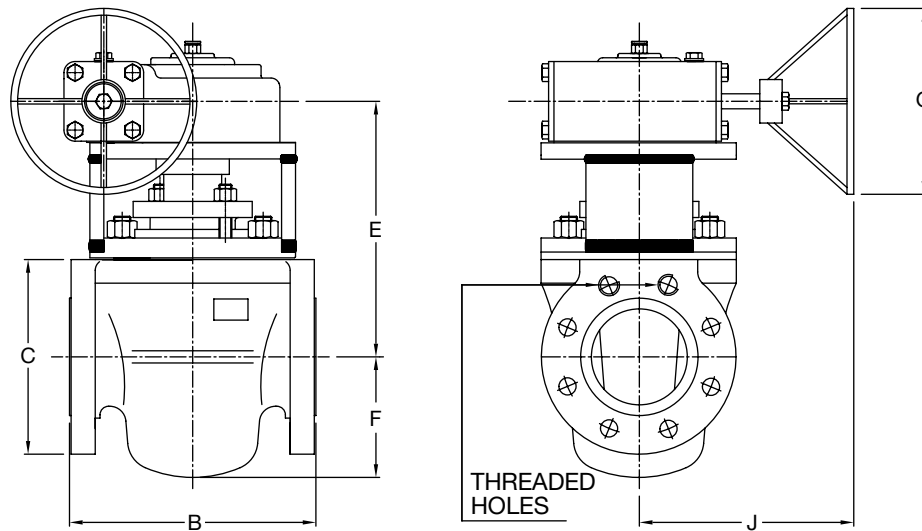

**SCR 03R - Short with Gear**

| Size  | Short Pattern |          |          |          |           |           |     |
|---|---------------|----------|----------|----------|-----------|-----------|-----|
|   | NPS<br>DN     | 5<br>125 | 6<br>150 | 8<br>200 | 10<br>250 | 12<br>300 |     |
| FACE TO FACE  | <b>B</b>      | mm       | 254      | 403      | 419       | 457       | 502 |
| FLANGE DIAMETER<br>DIN PN 40                        | <b>C</b>      | mm       | 270      | 300      | 375       | 450       | 515 |
| FLANGE DIAMETER<br>ANSI 300 RF                      | <b>C</b>      | mm       | 280      | 318      | 381       | 445       | 521 |
| CENTER LINE TO CENTER<br>OF HANDWHEEL               | <b>E</b>      | mm       | 550      | 575      | 600       | 630       | 690 |
| CENTER LINE<br>TO BOTTOM OF BODY                    | <b>F</b>      | mm       | 155      | 160      | 194       | 240       | 260 |
| HANDWHEEL<br>DIAMETER                               | <b>G</b>      | mm       | 560      | 560      | 560       | 560       | 560 |
| LONGITUDINAL<br>CENTER LINE TO<br>FACE OF HANDWHEEL | <b>J</b>      | mm       | 330      | 330      | 330       | 450       | 450 |
| WEIGHT PN 40  |               | kg       | 110      | 145      | 210       | 240       | 320 |
| WEIGHT ANSI 300                                     |               | kg       | 118      | 155      | 225       | 255       | 340 |



## Section 2 - Two Way Full Jacketed (Oversized Flanges)



## Full Bore Type Jacketed (Oversized Flanges)

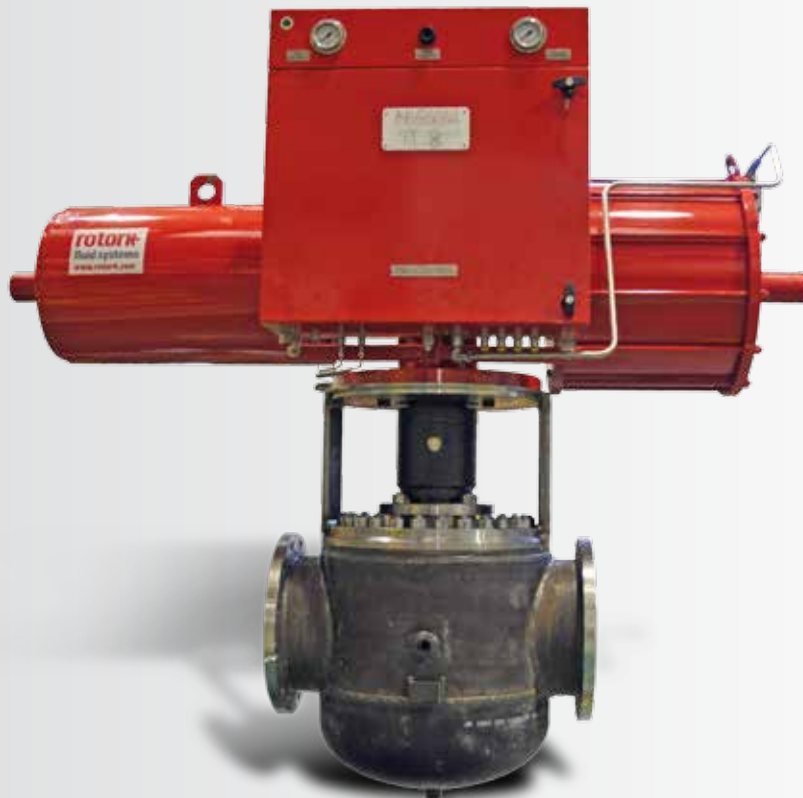



# ANSI Class 150 (PN 20)

## Steam Jacketed Body

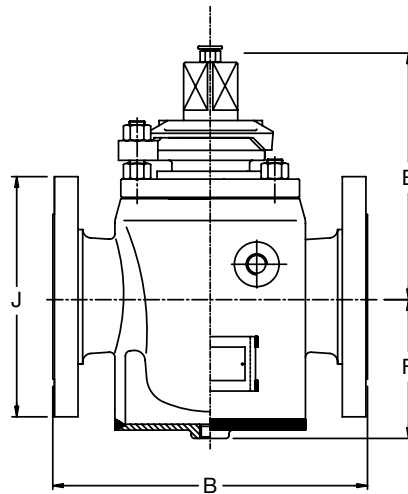

### VCC 01R - Short with Wrench

| Size  | NPS<br>DN   | Short Pattern |          |         |          |          |
|---|-------------|---------------|----------|---------|----------|----------|
|   |             | 2<br>50       | 2½<br>65 | 3<br>80 | 4<br>100 | 6<br>150 |
| FACE TO FACE<br>ANSI 150 RF                   | <b>B</b> mm | 178           | 191      | 203     | 229      | 267      |
| FLANGE DIAMETER<br>PN 16                      | <b>C</b> mm | 165           | 185      | 200     | 220      | 285      |
| FLANGE DIAMETER<br>ANSI 150                   | <b>C</b> mm | 152           | 178      | 191     | 229      | 279      |
| N. TAPPED HOLES<br>UNC THREADED<br>IN FLANGES |             | -             | -        | -       | -        | 2        |
| CENTER LINE<br>TO TOP OF STEM                 | <b>E</b> mm | 152           | 176      | 207     | 230      | 300      |
| CENTER LINE<br>TO BOTTOM OF BODY              | <b>F</b> mm | 103           | 115      | 136     | 151      | 210      |
| STEAM/CONDENSATE<br>N. HOLES ¾" N.P.T.        | <b>P</b>    | 3             | 3        | 3       | 3        | 3        |
| WEIGHT  | kg          | 16            | 24       | 31      | 43       | 105      |
| WRENCH - LENGHT                               | mm          | 320           | 400      | 500     | 570      | 1010     |





# ANSI Class 150 (PN 20)

## Steam Jacketed Body

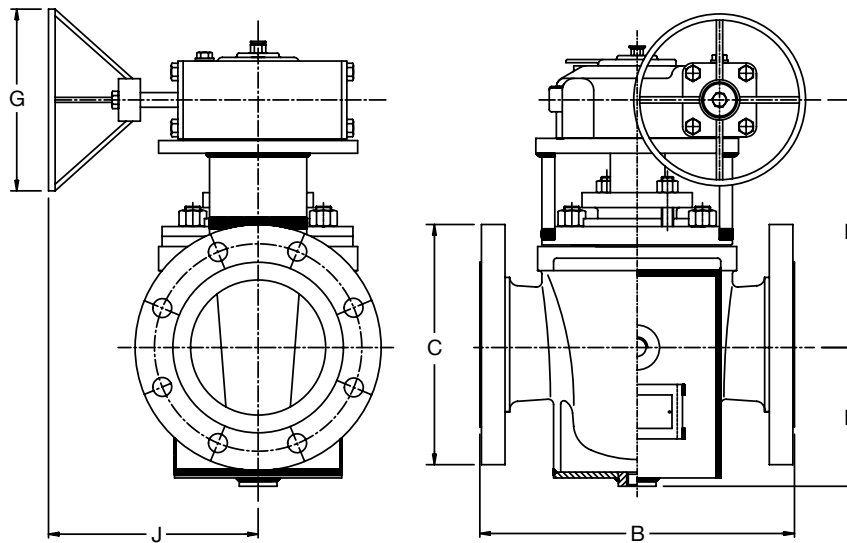

VCR 01R - Short with Gear

| Size  | NPS<br>DN   | Short Pattern |          |           |           |
|---|-------------|---------------|----------|-----------|-----------|
|   |             | 6<br>150      | 8<br>200 | 10<br>250 | 12<br>300 |
| FACE TO FACE  | <b>B</b> mm | 267           | 292      | 330       | 356       |
| FLANGE DIAMETER<br>DIN PN 16                        | <b>C</b> mm | 285           | 340      | 405       | 460       |
| FLANGE DIAMETER<br>ANSI 150 RF                      | <b>C</b> mm | 279           | 343      | 406       | 483       |
| N. TAPPED HOLES<br>UNC THREADED<br>IN FLANGES       |             | 2             | 2        | 2         | 4         |
| CENTER LINE TO CENTER<br>OF HANDWHEEL               | <b>E</b> mm | 570           | 600      | 630       | 690       |
| CENTER LINE<br>TO BOTTOM OF BODY                    | <b>F</b> mm | 200           | 235      | 270       | 334       |
| HANDWHEEL<br>DIAMETER                               | <b>G</b> mm | 560           | 560      | 560       | 560       |
| LONGITUDINAL<br>CENTER LINE TO<br>FACE OF HANDWHEEL | <b>J</b> mm | 330           | 330      | 450       | 450       |
| STEAM/CONDENSATE<br>N. HOLES $\frac{3}{4}$ " N.P.T. | <b>P</b>    | 3             | 3        | 3         | 3         |
| WEIGHT  | kg          | 140           | 180      | 230       | 325       |



# ANSI Class 150 (PN 20)

## Steam Jacketed Body

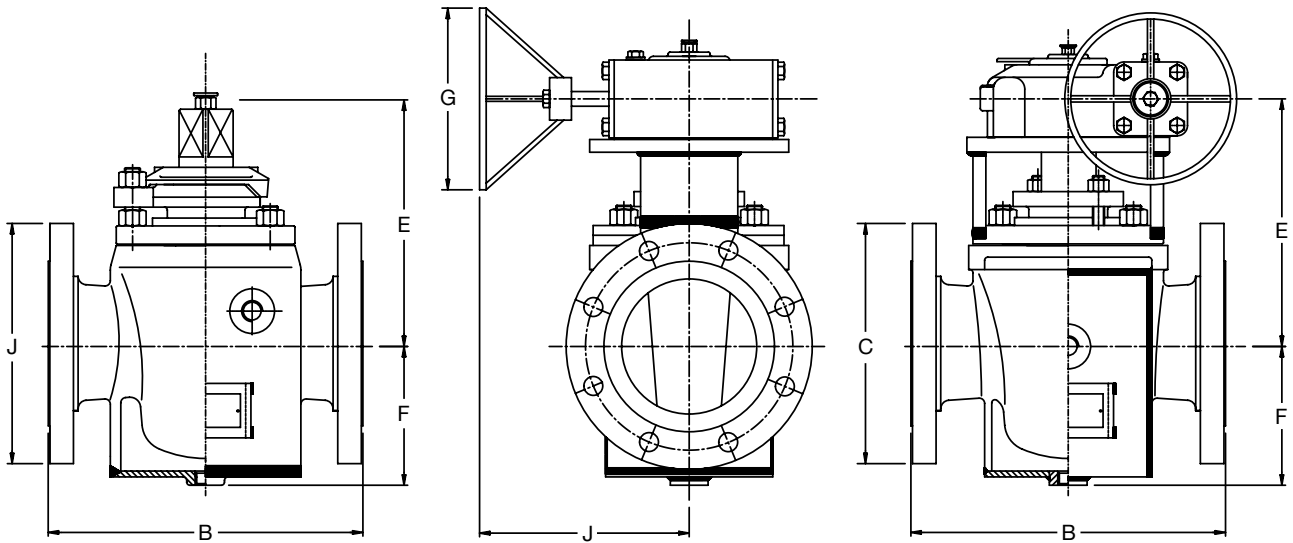

**VRC 01R - Regular with Wrench**

**VRR 01R - Regular with Gear**

| Size  | NPS<br>DN   | Regular Pattern |         |          |         |          |          |          |  |
|---|-------------|-----------------|---------|----------|---------|----------|----------|----------|--|
|   |             | 1½<br>40        | 2<br>50 | 2½<br>65 | 3<br>80 | 4<br>100 | 6<br>150 | 8<br>200 |  |
| FACE TO FACE  | <b>B</b> mm | 165             | 200     | 220      | 240     | 350      | 450      | 450      |  |
| FLANGE DIAMETER<br>DIN PN 16                        | <b>C</b> mm | 150             | 165     | 185      | 200     | 220      | 285      | 285      |  |
| FLANGE DIAMETER<br>ANSI 150                         | <b>C</b> mm | 127             | 152     | 178      | 191     | 229      | 279      | 279      |  |
| CENTER LINE<br>TO TOP OF STEM                       | <b>E</b> mm | 156             | 175     | 208      | 230     | 250      | 330      | -        |  |
| CENTER LINE TO CENTER<br>OF HANDWHEEL               | <b>E</b> mm | -               | -       | -        | -       | -        | -        | 650      |  |
| CENTER LINE<br>TO BOTTOM OF BODY                    | <b>F</b> mm | 97              | 115     | 130      | 145     | 180      | 245      | 245      |  |
| HANDWHEEL DIAMETER                                  | <b>G</b> mm | -               | -       | -        | -       | -        | 560      | 560      |  |
| LONGITUDINAL<br>CENTER LINE<br>TO FACE OF HANDWHEEL | <b>J</b> mm | -               | -       | -        | -       | -        | 330      | 330      |  |
| STEAM/CONDENSATE<br>N. HOLES ¾" N.P.T.              | <b>P</b>    | 3               | 3       | 3        | 3       | 3        | 3        | 3        |  |
| WEIGHT  | kg          | 14              | 22      | 30       | 36      | 80       | 154      | 175      |  |
| WRENCH - LENGHT                                     | mm          | 320             | 400     | 500      | 570     | 720      | -        | -        |  |



# ANSI Class 300 (PN 50)

## Steam Jacketed Body

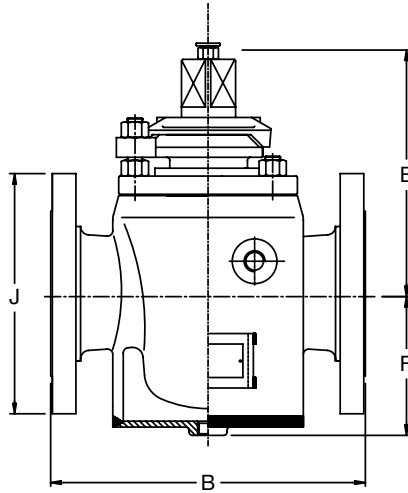

VCC 03R - Short with Wrench

| Size                                   | NPS<br>DN   | Short Pattern |         |          |         |          |  |
|--|-------------|---------------|---------|----------|---------|----------|--|
|  |             | 1½<br>40      | 2<br>50 | 2½<br>65 | 3<br>80 | 4<br>100 |  |
| FACE TO FACE                           | <b>B</b> mm | 190           | 216     | 241      | 283     | 305      |  |
| FLANGE DIAMETER<br>DIN PN 40           | <b>C</b> mm | 150           | 165     | 185      | 200     | 235      |  |
| FLANGE DIAMETER<br>ANSI 300 RF         | <b>C</b> mm | 156           | 165     | 191      | 210     | 254      |  |
| CENTER LINE<br>TO TOP OF STEAM         | <b>E</b> mm | 156           | 175     | 208      | 230     | 250      |  |
| CENTER LINE<br>TO BOTTOM OF BODY       | <b>F</b> mm | 97            | 115     | 130      | 145     | 180      |  |
| STEAM/CONDENSATE<br>N. HOLES ¾" N.P.T. | <b>P</b>    | 3             | 3       | 3        | 3       | 3        |  |
| WEIGHT PN 40                           | kg          | 14            | 22      | 30       | 36      | 86       |  |
| WEIGHT ANSI 300                        | kg          | 17            | 23      | 32       | 42      | 95       |  |
| WRENCH - LENGHT                        | mm          | 320           | 400     | 500      | 570     | 720      |  |



# ANSI Class 300 (PN 50)

## Steam Jacketed Body

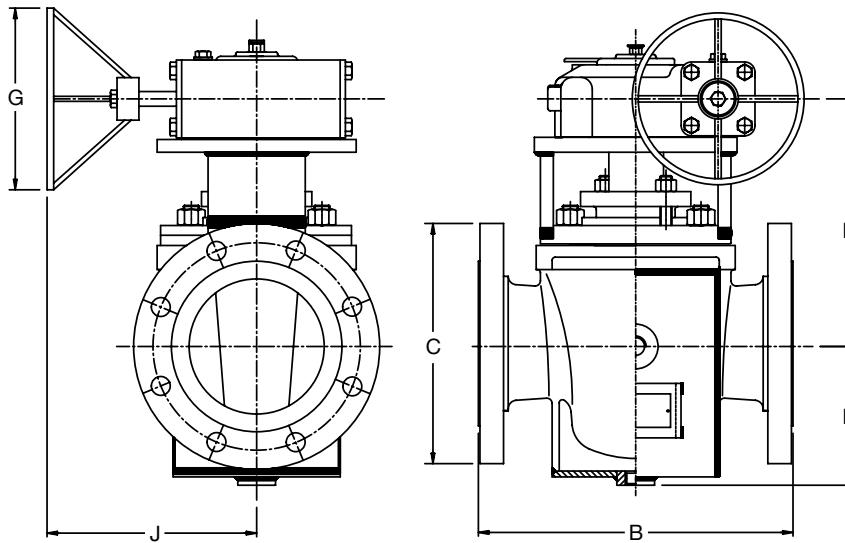

VCR 03R - Regular with Gear

| Size  | NPS<br>DN   | Short Pattern |          |           |           |
|---|-------------|---------------|----------|-----------|-----------|
|   |             | 6<br>150      | 8<br>200 | 10<br>250 | 12<br>300 |
| FACE TO FACE  | <b>B</b> mm | 403           | 419      | 457       | 502       |
| FLANGE DIAMETER<br>DIN PN 40                        | <b>C</b> mm | 300           | 375      | 450       | 515       |
| FLANGE DIAMETER<br>ANSI 300 RF                      | <b>C</b> mm | 318           | 381      | 445       | 521       |
| CENTER LINE TO TOP<br>OF HANDWHEEL                  | <b>E</b> mm | 575           | 615      | 645       | 700       |
| CENTER LINE<br>TO BOTTOM OF BODY                    | <b>F</b> mm | 220           | 255      | 295       | 310       |
| HANDWHEEL DIAMETER                                  | <b>G</b> mm | 560           | 560      | 560       | 560       |
| LONGITUDINAL<br>CENTER LINE<br>TO FACE OF HANDWHEEL | <b>J</b> mm | 330           | 330      | 450       | 450       |
| STEAM/CONDENSATE<br>N. HOLES $\frac{3}{4}$ " N.P.T. | <b>P</b>    | 3             | 3        | 33        |           |
| WEIGHT PN 40  | kg          | 180           | 250      | 320       | 445       |
| WEIGHT ANSI 300                                     | kg          | 190           | 260      | 330       | 460       |





# ANSI Class 150 (PN 20)

## Full Jacketed Body

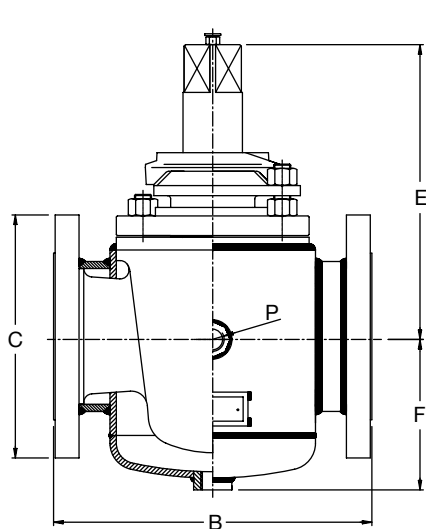

**ZRC 01R - Regular with Wrench**

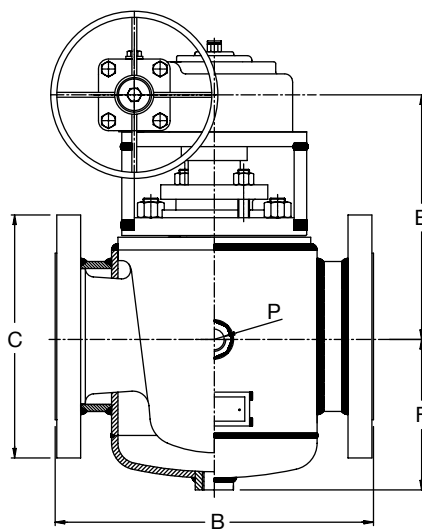

**ZRR 01R - Regular with Gear**

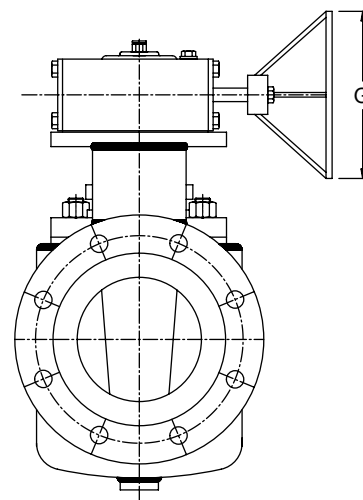

| Size                                  | NPS<br>DN                     | Regular Pattern |                  |              |               |                |                |                 |  |
|---------------------------------------|-------------------------------|-----------------|------------------|--------------|---------------|----------------|----------------|-----------------|--|
|                                       |                               | 1x2<br>25x50    | 1½ x 2½<br>40x65 | 2x3<br>50x80 | 3x4<br>80x100 | 4x6<br>100x150 | 6x8<br>150x200 | 8x10<br>200x250 |  |
| FACE TO FACE                          | <b>B</b> mm                   | 200             | 220              | 240          | 300           | 390            | 419            | 457             |  |
| FLANGE DIAMETER<br>PN 16              | <b>C</b> mm                   | 165             | 185              | 200          | 220           | 285            | 340            | 405             |  |
| FLANGE DIAMETER<br>ANSI 150           | <b>C</b> mm                   | 152             | 178              | 191          | 229           | 279            | 343            | 406             |  |
| CENTER LINE<br>TO TOP OF STEM         | <b>E</b> mm                   | 120             | 156              | 175          | 230           | 245            | --             |                 |  |
| CENTER LINE<br>TO BOTTOM OF BODY      | <b>F</b> mm                   | 75              | 97               | 115          | 145           | 175            | 220            | 260             |  |
| CENTER LINE TO CENTER<br>OF HANDWHEEL | <b>E</b> mm                   | -               | -                | -            | -             | -              | 500            | 615             |  |
| HANDWHEEL<br>DIAMETER                 | mm                            | -               | -                | -            | -             | -              | 560            | 560             |  |
| STEAM/INLET<br>N. 2 HOLES N.P.T.      | <b>P<sub>1</sub> or P</b> in. | ½ - ¾           | ¾ - 1            | ¾ - 1        | ¾ - 1         | ¾ - 1          | ¾ - 1          | ¾ - 1           |  |
| CONDENSATE OUTLET<br>N. 1 HOLE N.P.T. | <b>P<sub>2</sub></b> in.      | ¾               | 1                | 1            | 1             | 1              | 1              | 1               |  |
| WRENCH - LENGHT                       | mm                            | 235             | 320              | 400          | 570           | 720            | -              | -               |  |
| WEIGHT                                | kg                            | 13              | 20               | 27           | 45            | 115            | 210            | 270             |  |



# ANSI Class 150 (PN 20)

## Full Jacketed Body

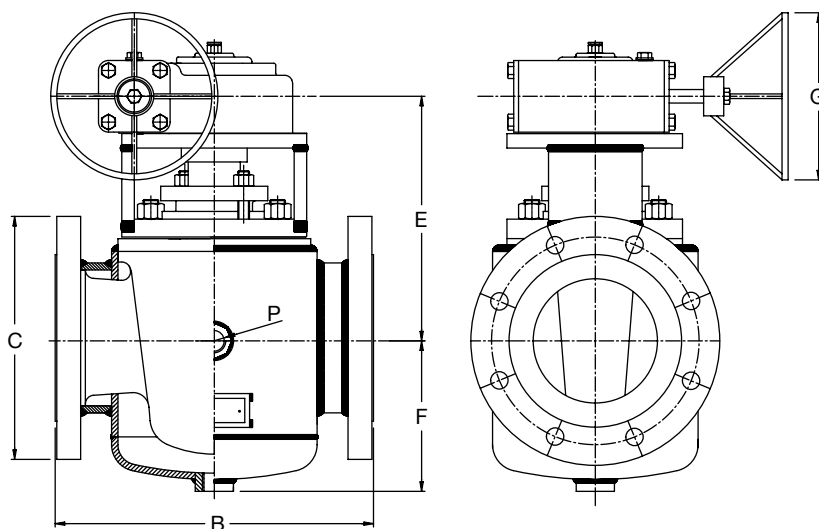

**ZRR 01R - Regular with Gear**

| Size                                  | Regular Pattern               |                  |                  |                  |                  |                  |                  |                  |  |
|---------------------------------------|-------------------------------|------------------|------------------|------------------|------------------|------------------|------------------|------------------|--|
|                                       | NPS<br>DN                     | 10x12<br>250x300 | 12x14<br>300x350 | 14x16<br>350x400 | 16x18<br>400x450 | 18x20<br>450x500 | 20x24<br>500x600 | 24x26<br>600x650 |  |
| FACE TO FACE                          | <b>B</b> mm                   | 502              | 762              | 762              | 838              | 914              | 991              | 1143             |  |
| FLANGE DIAMETER<br>DIN PN 16          | <b>C</b> mm                   | 460              | 520              | 580              | 640              | 715              | 840              | ★                |  |
| FLANGE DIAMETER<br>ANSI 150           | <b>C</b> mm                   | 483              | 533              | 597              | 635              | 699              | 813              | 870              |  |
| CENTER LINE<br>TO BOTTOM OF BODY      | <b>F</b> mm                   | 380              | 400              | 445              | 465              | 525              | 590              | 675              |  |
| CENTER LINE TO CENTER<br>OF HANDWHEEL | <b>E</b> mm                   | 530              | 660              | 660              | 660              | 745              | 835              | 910              |  |
| HANDWHEEL<br>DIAMETER                 | mm                            | 800              | 1000             | 1000             | 1000             | 1000             | 1000             | 1000             |  |
| STEAM/INLET<br>N. 2 HOLES N.P.T.      | <b>P<sub>1</sub> or P</b> in. | 3/4 - 1          | 3/4 - 1          | 3/4 - 1          | 3/4 - 1          | 3/4 - 1          | 3/4 - 1          | 3/4 - 1          |  |
| CONDENSATE OUTLET<br>N. 1 HOLE N.P.T. | <b>P<sub>2</sub></b> in.      | 1                | 1                | 1                | 1                | 1                | 1                | 1                |  |
| WEIGHT                                | kg                            | 360              | 525              | 690              | 965              | 1240             | 1480             | 2160             |  |

\* **Note:** To be confirmed.



# ANSI Class 300 (PN 50)

## Full Jacketed Body

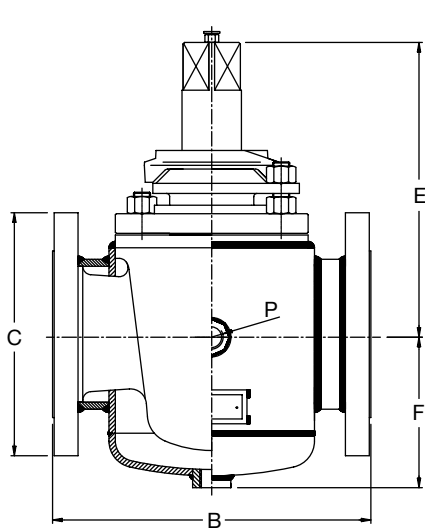

**ZRC 03R - Regular with Wrench**

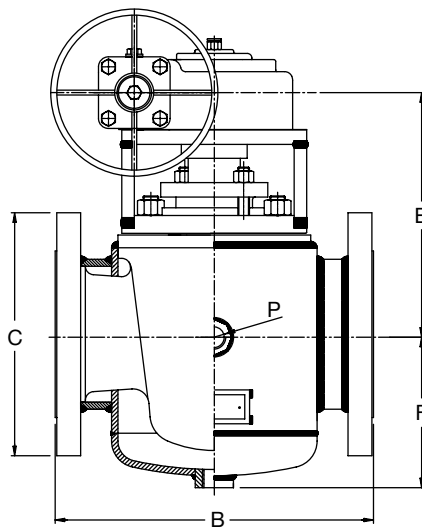

**ZRR 03R - Regular with Gear**

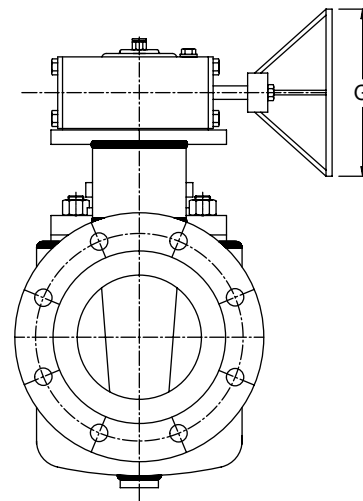

| Size                                  | Regular Pattern               |              |                |              |               |                |                |                 |  |
|---------------------------------------|-------------------------------|--------------|----------------|--------------|---------------|----------------|----------------|-----------------|--|
|                                       | NPS<br>DN                     | 1x2<br>25x50 | 1½x2½<br>40x65 | 2x3<br>50x80 | 3x4<br>80x100 | 4x6<br>100x150 | 6x8<br>150x200 | 8x10<br>200x250 |  |
| FACE TO FACE                          | <b>B</b> mm                   | 200          | 240            | 260          | 300           | 403            | 419            | 457             |  |
| FLANGE DIAMETER<br>DIN PN 40          | <b>C</b> mm                   | 165          | 185            | 200          | 235           | 300            | 375            | 450             |  |
| FLANGE DIAMETER<br>ANSI 300           | <b>C</b> mm                   | 165          | 191            | 210          | 254           | 318            | 381            | 445             |  |
| CENTER LINE<br>TO TOP OF STEM         | <b>E</b> mm                   | 110          | 156            | 175          | 230           | 245            | -              | -               |  |
| CENTER LINE<br>TO BOTTOM OF BODY      | <b>F</b> mm                   | 70           | 97             | 115          | 145           | 175            | 220            | 260             |  |
| CENTER LINE TO CENTER<br>OF HANDWHEEL | <b>E</b> mm                   | -            | -              | -            | -             | -              | 500            | 615             |  |
| HANDWHEEL<br>DIAMETER                 | mm                            | -            | -              | -            | -             | -              | 700            | 800             |  |
| STEAM/INLET<br>N. 2 HOLES N.P.T.      | <b>P<sub>1</sub> or P</b> in. | ½ - ¾        | ¾ - 1          | ¾ - 1        | ¾ - 1         | ¾ - 1          | ¾ - 1          | ¾ - 1           |  |
| CONDENSATE OUTLET<br>N. 1 HOLE N.P.T. | <b>P<sub>2</sub></b> in.      | ¾            | 1              | 1            | 1             | 1              | 1              | 1               |  |
| WEIGHT                                | kg                            | 18           | 28             | 38           | 63            | 160            | 290            | 370             |  |
| WRENCH - LENGHT                       | mm                            | 300          | 300            | 400          | 570           | 720            | -              | -               |  |



# ANSI Class 300 (PN 50)

## Full Jacketed Body

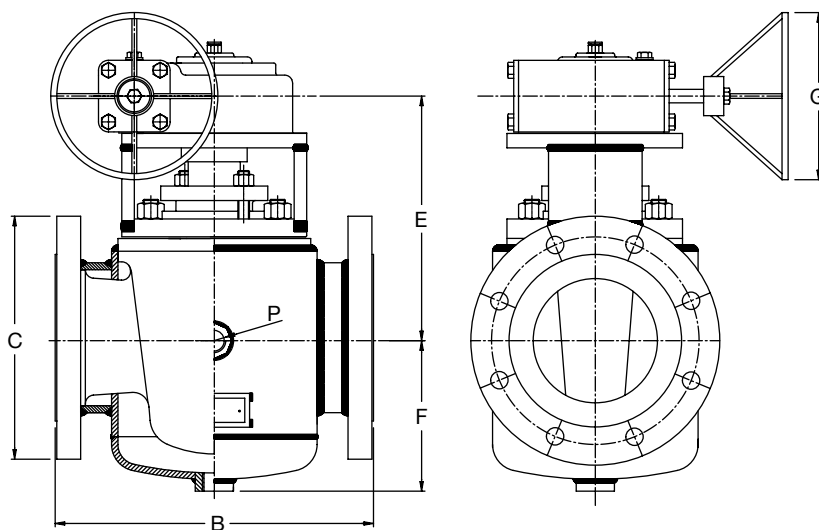

**ZRR 03R - Regular with Gear**

| Size                                  | Regular Pattern           |                  |                  |                  |                  |                  |                  |                  |         |
|---------------------------------------|---------------------------|------------------|------------------|------------------|------------------|------------------|------------------|------------------|---------|
|                                       | NPS<br>DN                 | 10x12<br>250x300 | 12x14<br>300x350 | 14x16<br>350x400 | 16x18<br>450x500 | 18x20<br>450x500 | 20x24<br>500x600 | 24x26<br>600x650 |         |
| FACE TO FACE                          | <b>B</b>                  | mm               | 502              | 762              | 762              | 838              | 914              | 991              | 1143    |
| FLANGE DIAMETER<br>DIN PN 40          | <b>C</b>                  | mm               | 515              | 580              | 660              | 685              | 755              | 890              | ★       |
| FLANGE DIAMETER<br>ANSI 300           | <b>C</b>                  | mm               | 521              | 584              | 648              | 711              | 775              | 914              | 972     |
| CENTER LINE<br>TO BOTTOM OF BODY      | <b>F</b>                  | mm               | 380              | 400              | 445              | 465              | 525              | 590              | 675     |
| CENTER LINE TO CENTER<br>OF HANDWHEEL | <b>E</b>                  | mm               | 521              | 660              | 660              | 660              | 745              | 835              | 915     |
| HANDWHEEL<br>DIAMETER                 |                           | mm               | 800              | 800              | 1000             | 1000             | 1000             | 1000             | 1000    |
| STEAM/INLET<br>N. 2 HOLES N.P.T.      | <b>P<sub>1</sub> or P</b> | in.              | 3/4 - 1          | 3/4 - 1          | 3/4 - 1          | 3/4 - 1          | 3/4 - 1          | 3/4 - 1          | 3/4 - 1 |
| CONDENSATE OUTLET<br>N. 1 HOLE N.P.T. | <b>P<sub>2</sub></b>      | in.              | 1                | 1                | 1                | 1                | 1                | 1                | 1       |
| WEIGHT                                |                           | kg               | 420              | 570              | 720              | 985              | 1260             | 1780             | 2590    |

\* **Note:** To be confirmed.





# ANSI Class 150 (PN 20)

## Full Jacketed - Full Bore

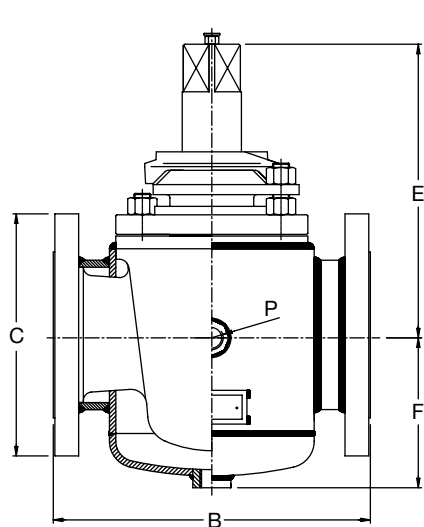

**ZFC 01R - Full with Wrench**

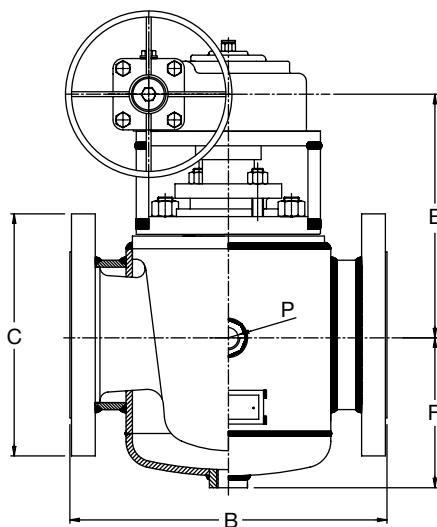

**ZFR 01R - Full with Gear**

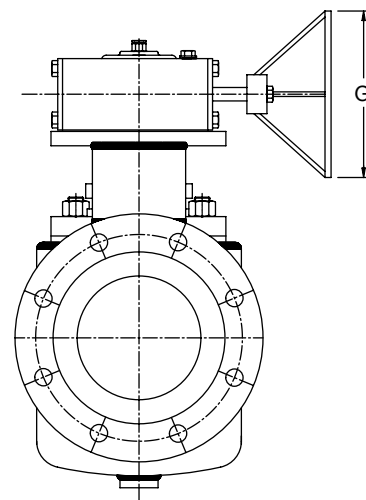

| Size                                  | NPS<br>DN                     | Full Bore    |              |               |                |                |                 |                  |
|---------------------------------------|-------------------------------|--------------|--------------|---------------|----------------|----------------|-----------------|------------------|
|                                       |                               | 1x2<br>25x50 | 2x3<br>50x80 | 3x4<br>80x100 | 4x6<br>100x150 | 6x8<br>150x200 | 8x10<br>200x250 | 10x12<br>250x300 |
| FACE TO FACE                          | <b>B</b> mm                   | 178          | 267          | 343           | 432            | 546            | 622             | 826              |
| FLANGE DIAMETER<br>DIN PN 16          | <b>C</b> mm                   | 165          | 200          | 220           | 285            | 340            | 405             | 460              |
| FLANGE DIAMETER<br>ANSI 150           | <b>C</b> mm                   | 153          | 191          | 229           | 280            | 343            | 406             | 483              |
| CENTER LINE<br>TO TOP OF STEM         | <b>E</b> mm                   | 110          | 185          | 205           | 240            | -              | -               | -                |
| CENTER LINE<br>TO BOTTOM OF BODY      | <b>F</b> mm                   | 70           | 120          | 140           | 178            | 220            | 235             | 526              |
| CENTER LINE TO CENTER<br>OF HANDWHEEL | <b>E</b> mm                   | -            | -            | -             | -              | 340            | 390             | 504              |
| HANDWHEEL<br>DIAMETER                 | mm                            | -            | -            | -             | -              | -              | 800             | 800              |
| STEAM/INLET<br>N. 2 HOLES N.P.T.      | <b>P<sub>1</sub> or P</b> in. | 1/2 - 3/4    | 3/4 - 1      | 3/4 - 1       | 3/4 - 1        | 3/4 - 1        | 3/4 - 1         | 3/4 - 1          |
| CONDENSATE OUTLET<br>N. 1 HOLE N.P.T. | <b>P<sub>2</sub></b> in.      | 3/4          | 1            | 1             | 1              | 1              | 1               | 1                |
| WRENCH - LENGHT                       | mm                            | 300          | 500          | 500           | 550            | -              | -               | -                |



# ANSI Class 300 (PN 50)

## Full Jacketed - Full Bore

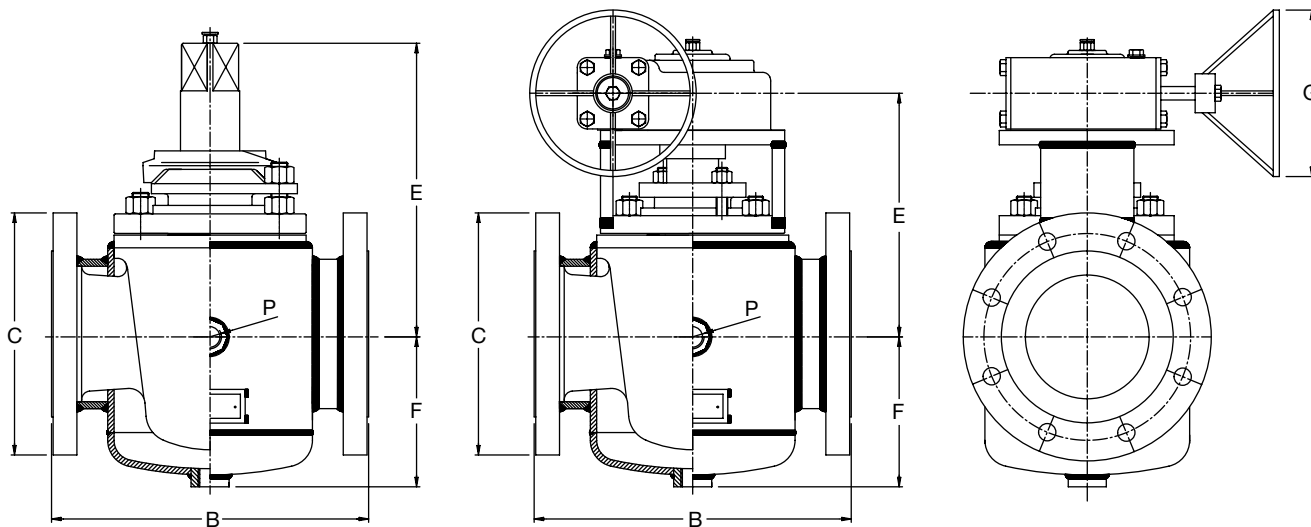

**ZFC 03R - Full with Wrench**

**ZFR 03R - Full with Gear**

| Size                                  | NPS<br>DN                     | Full Bore    |              |               |                |                |                 |                  |
|---------------------------------------|-------------------------------|--------------|--------------|---------------|----------------|----------------|-----------------|------------------|
|                                       |                               | 1x2<br>25x50 | 2x3<br>50x80 | 3x4<br>80x100 | 4x6<br>100x150 | 6x8<br>150x200 | 8x10<br>200x250 | 10x12<br>250x300 |
| FACE TO FACE                          | <b>B</b> mm                   | 191          | 283          | 387           | 457            | 559            | 686             | 826              |
| FLANGE DIAMETER<br>DIN PN 40          | <b>C</b> mm                   | 165          | 200          | 235           | 300            | 375            | 450             | 515              |
| FLANGE DIAMETER<br>ANSI 300           | <b>C</b> mm                   | 165          | 210          | 254           | 318            | 381            | 445             | 521              |
| CENTER LINE<br>TO TOP OF STEM         | <b>E</b> mm                   | 110          | 185          | 205           | 240            | -              | -               | -                |
| CENTER LINE<br>TO BOTTOM OF BODY      | <b>F</b> mm                   | 70           | 120          | 140           | 178            | 220            | 235             | 526              |
| CENTER LINE TO CENTER<br>OF HANDWHEEL | <b>E</b> mm                   | -            | -            | -             | -              | 340            | 390             | 504              |
| HANDWHEEL<br>DIAMETER                 | mm                            | -            | -            | -             | -              | -              | 800             | 800              |
| STEAM/INLET<br>N. 2 HOLES N.P.T.      | <b>P<sub>1</sub> or P</b> in. | 1/2 - 3/4    | 3/4 - 1      | 3/4 - 1       | 3/4 - 1        | 3/4 - 1        | 3/4 - 1         | 3/4 - 1          |
| CONDENSATE OUTLET<br>N. 1 HOLE N.P.T. | <b>P<sub>2</sub></b> in.      | 3/4          | 1            | 1             | 1              | 1              | 1               | 1                |
| WRENCH - LENGHT                       | mm                            | 300          | 500          | 500           | 550            | -              | -               | -                |



## Section 3 - Multiport Three-Four Way Valves

*Multiport plug valves are built with the same characteristics such as the two way standard valves or inverted*

*plug valves. Application of multiport plug valve gives more advantages than two way valves.*

*In fact it can simplify the loop in diverting or mixing flow systems, reducing the cost of other components in the plant*

*such as flanges, pipes and fittings. Three way plug valves can be made regular and transflow pattern.*

### Regular Pattern

This design avoids mixture of the fluids in the body, in fact when the plug is turned from one position A to another B, the fluid in B starts to open as soon as the first fluid A is insulated.

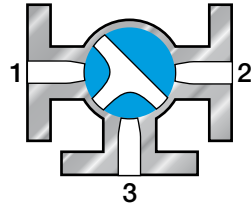

### Transflow Pattern

This design is the right solution when temporary shutt off of the flow is not allowed. Therefore when the plug is turned from one position A to another B, the fluid in B starts to open before the first one is completely insulated.

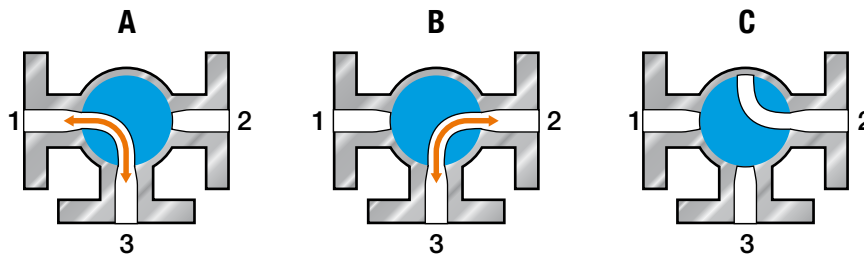
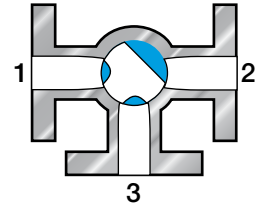

3 Way - L Ported Valves

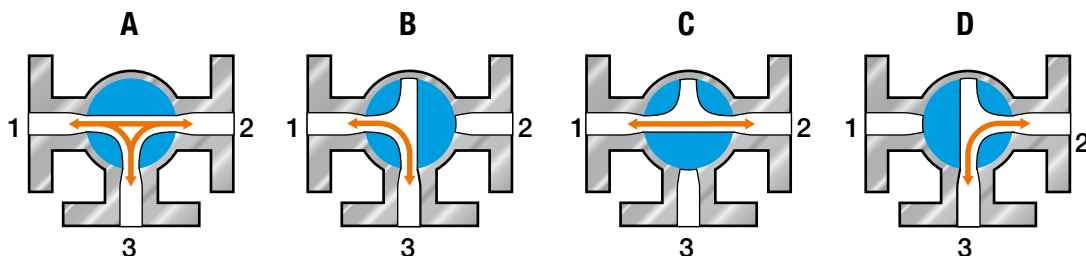

3 Way - T Ported Valves

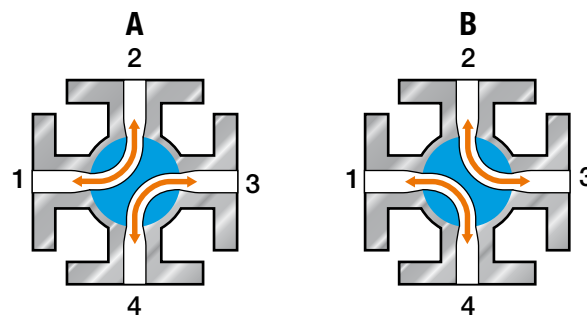

4 Way - Double Ported Valves

Four way valves can only be used as distributor,

they cannot be expected to guarantee tightness under

high differential pressure without some leakage from

one side of the valve to the other.



# ANSI Class 150 (PN 20)

## 3 and 4 Way - Type - (Transflow/Regular)

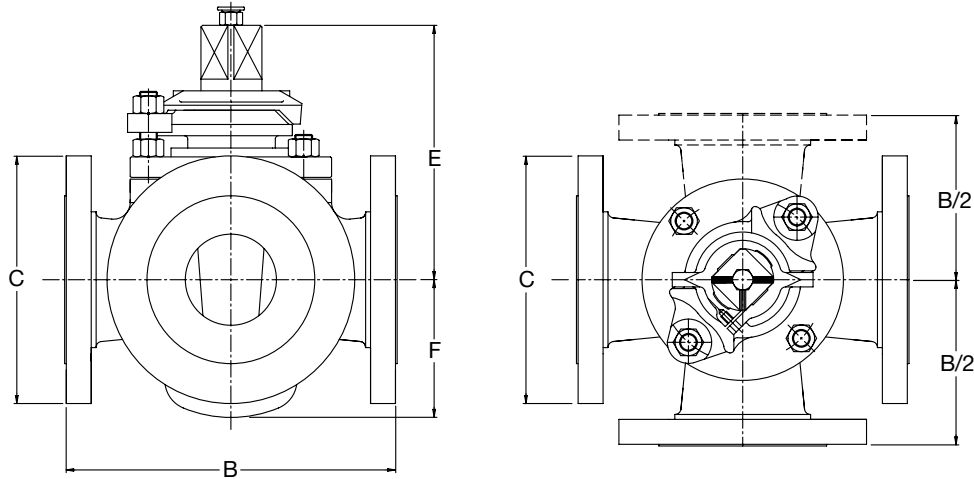

**MRC 01R - 3 way T port with Wrench**  
**LRC 01R - 3 way L port with Wrench**  
**URC 01R - 4 way with Wrench**

| Size                             | NPS<br>DN   | Long Pattern |          |          |         |          |         |          |          |
|----------------------------------|-------------|--------------|----------|----------|---------|----------|---------|----------|----------|
|                                  |             | 1<br>25      | 1¼<br>32 | 1½<br>40 | 2<br>50 | 2½<br>65 | 3<br>80 | 4<br>100 | 5<br>125 |
| FACE TO FACE                     | <b>B</b> mm | 165          | 200      | 220      | 267     | 267      | 300     | 350      | 390      |
| FLANGE DIAMETER<br>DIN PN 16     | <b>C</b> mm | 115          | 140      | 150      | 165     | 185      | 200     | 220      | 250      |
| FLANGE DIAMETER<br>ANSI 150      | <b>C</b> mm | 108          | 117      | 127      | 152     | 178      | 191     | 229      | 254      |
| CENTER LINE<br>TO TOP OF STEM    | <b>E</b> mm | 140          | 157      | 177      | 200     | 230      | 250     | 265      | 305      |
| CENTER LINE<br>TO BOTTOM OF BODY | <b>F</b> mm | 60           | 65       | 76       | 92      | 108      | 136     | 147      | 165      |
| WEIGHT THREE WAY                 | kg          | 10           | 16       | 18       | 25      | 36       | 55      | 80       | 100      |
| WEIGHT FOUR WAY                  | kg          | 14           | 20       | 22       | 30      | 42       | 65      | 95       | 120      |
| WRENCH - LENGHT                  | mm          | 320          | 320      | 400      | 500     | 570      | 720     | 1010     | 1030     |





# ANSI Class 150 (PN 20)

## 3 and 4 Way - Type - (Transflow)

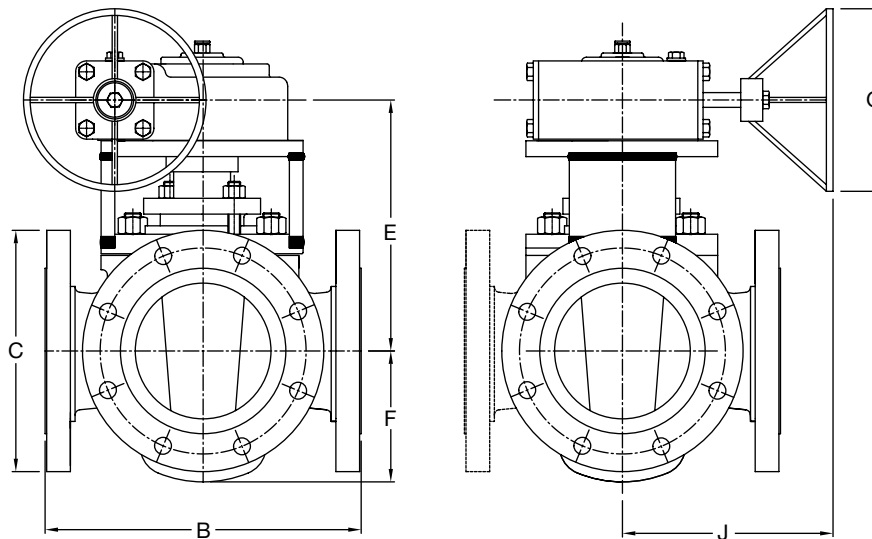

**MRR 01R - 3 way T port with Wrench**  
**LRR 01R - 3 way L port with Wrench**  
**URR 01R - 4 way with Gear (Not Shown)**

| Size  | NPS<br>DN   | Long Pattern |          |          |          |
|---|-------------|--------------|----------|----------|----------|
|   |             | 4<br>100     | 5<br>125 | 6<br>150 | 8<br>200 |
| FACE TO FACE  | <b>B</b> mm | 350          | 413      | 457      | 508      |
| FLANGE DIAMETER<br>DIN PN 16                        | <b>C</b> mm | 220          | 250      | 285      | 340      |
| FLANGE DIAMETER<br>ANSI 150                         | <b>C</b> mm | 229          | 254      | 279      | 343      |
| CENTER LINE TO CENTER<br>OF HANDWHEEL               | <b>E</b> mm | 550          | 586      | 656      | 686      |
| CENTER LINE<br>TO BOTTOM OF BODY                    | <b>F</b> mm | 147          | 165      | 215      | 270      |
| HANDWHEEL<br>DIAMETER                               | <b>G</b> mm | 560          | 560      | 700      | 700      |
| LONGITUDINAL<br>CENTER LINE<br>TO FACE OF HANDWHEEL | <b>J</b>    | 260          | 330      | 330      | 450      |
| WEIGHT THREE WAY                                    | kg          | 110          | 140      | 220      | 290      |
| WEIGHT FOUR WAY                                     | kg          | 125          | 160      | 260      | 320      |



# ANSI Class 300 (PN 50)

## 3 and 4 Way (Regular)

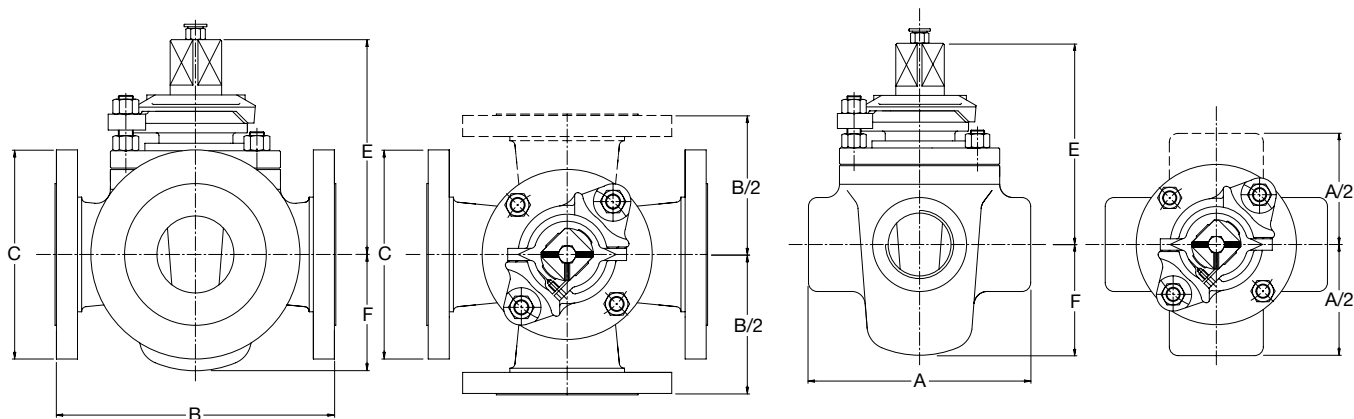

**MRC 03T - 3 way T port with Wrench**  
**LRC 03T - 3 way L port with Wrench**  
**URC 03T - 4 way with Wrench**

**MRC 03R - 3 way T port with Wrench**  
**LRC 03R - 3 way L port with Wrench**  
**URC 03R - 4 way with Wrench**

| Size                             | NPS<br>DN | Long Pattern |           |         |             |         |         |          |      |
|----------------------------------|-----------|--------------|-----------|---------|-------------|---------|---------|----------|------|
|                                  |           | 1/2<br>15    | 3/4<br>20 | 1<br>25 | 1 1/2<br>40 | 2<br>50 | 3<br>80 | 4<br>100 |      |
| FACE TO END                      | <b>A</b>  | mm           | 110       | 110     | 135         | 145     | 170     | -        | -    |
| FACE TO FACE                     | <b>B</b>  | mm           | 150       | 170     | 190         | 240     | 283     | 335      | 410  |
| FLANGE DIAMETER<br>DIN PN 40     | <b>C</b>  | mm           | 95        | 105     | 115         | 150     | 165     | 200      | 235  |
| FLANGE DIAMETER<br>ANSI 300      | <b>C</b>  | mm           | 95        | 117     | 124         | 156     | 165     | 210      | 254  |
| CENTER LINE<br>TO TOP OF STEM    | <b>E</b>  | mm           | 107       | 107     | 140         | 177     | 200     | 243      | 292  |
| CENTER LINE<br>TO BOTTOM OF BODY | <b>F</b>  | mm           | 42        | 42      | 60          | 77      | 92      | 128      | 150  |
| WEIGHT 3 WAY<br>THREADED ENDS    | kg        |              | 4         | 4       | 6           | 15      | 20      | -        | -    |
| WEIGHT 4 WAY<br>THREADED ENDS    | kg        |              | 4,5       | 5       | 7,5         | 16      | 22      | -        | -    |
| WEIGHT 3 WAY<br>FLANGED          | kg        |              | 6,5       | 6       | 10          | 20      | 28      | 67       | 103  |
| WEIGHT 4 WAY<br>FLANGED          | kg        |              | -         | 8,5     | 12          | 24      | 35      | 82       | 120  |
| WRENCH - LENGTH                  | mm        |              | 235       | 235     | 320         | 400     | 500     | 720      | 1010 |



# ANSI Class 300 (PN 50)

## 3 and 4 Way - Type - (Transflow)

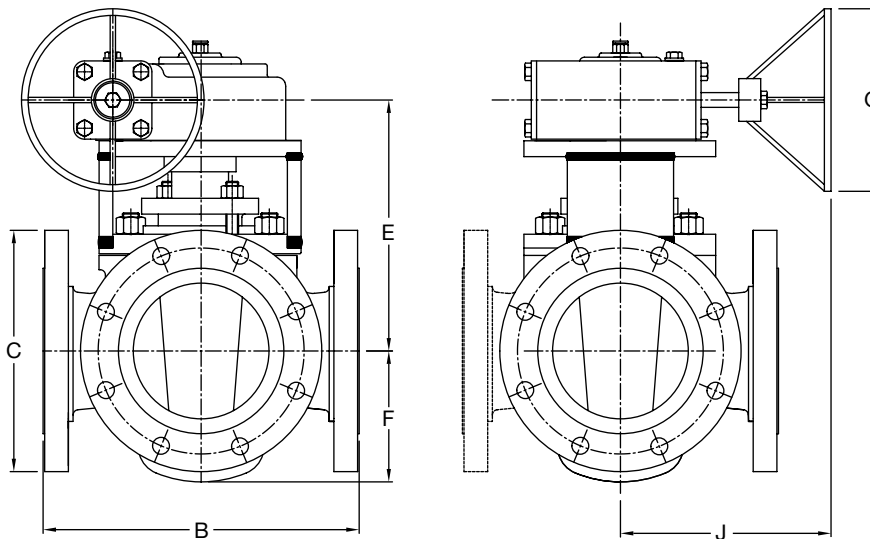

**MRR 03R - 3 way T port with Gear**  
**LRR 03R - 3 way L port with Gear**  
**URR 03R - 4 way with Gear (Not Shown)**

| Size  | NPS<br>DN   | Long Pattern |          |          |          |
|---|-------------|--------------|----------|----------|----------|
|   |             | 4<br>100     | 5<br>125 | 6<br>150 | 8<br>200 |
| FACE TO FACE  | <b>B</b> mm | 410          | 450      | 502      | 568      |
| FLANGE DIAMETER<br>DIN PN 40                        | <b>C</b> mm | 235          | 270      | 300      | 375      |
| FLANGE DIAMETER<br>ANSI 300                         | <b>C</b> mm | 254          | 279      | 318      | 381      |
| CENTER LINE TO CENTER<br>OF HANDWHEEL               | <b>E</b> mm | 550          | 586      | 656      | 686      |
| CENTER LINE<br>TO BOTTOM OF BODY                    | <b>F</b> mm | 147          | 165      | 215      | 270      |
| HANDWHEEL<br>DIAMETER                               | <b>G</b> mm | 560          | 560      | 700      | 700      |
| LONGITUDINAL<br>CENTER LINE<br>TO FACE OF HANDWHEEL | <b>J</b>    | 260          | 330      | 330      | 450      |
| WEIGHT THREE WAY                                    | kg          | 132          | 168      | 260      | 350      |
| WEIGHT FOUR WAY                                     | kg          | 150          | 190      | 312      | 385      |



# Engineering Data





## Hydrostatic-Test

| Valve Rating    | M.O.P. |                     | Body Test (minimum) |                     | Seat Test (minimum) |                     |
|-----------------|--------|---------------------|---------------------|---------------------|---------------------|---------------------|
|                 | bar    | lbf/in <sup>2</sup> | bar                 | lbf/in <sup>2</sup> | bar                 | lbf/in <sup>2</sup> |
| CLASS 125 PN 10 | 12,0   | 175                 | 24                  | 350                 | 12.0                | 175                 |
| CLASS 150 PN 20 | 19.0   | 275                 | 29                  | 425                 | 21                  | 300                 |
| CLASS 300 PN 50 | 49.6   | 720                 | 76                  | 1100                | 55                  | 800                 |

## Duration of Hydrostatic Test in Minutes (minimum)

| Valve Size       | API 598      |           | API 6 D    |                |
|------------------|--------------|-----------|------------|----------------|
|                  | Shell Test   | Seat Test | Shell Test | Seat Test      |
| ≤ 50 mm          | ≤ 2"         | 1/4       | 1/4        | not applicable |
| 50 mm to 100 mm  | 2" to 4"     | -         | -          | 2              |
| 65 mm to 150 mm  | 2 1/2" to 6" | 1         | 1          | 2              |
| 150 mm to 250 mm | -            | -         | 5          | 5              |
| 200 mm to 300 mm | 8" to 12"    | 2         | 2          | 5              |

API 6D also requires a 5.5 bar (80 PSI) air test on the seat for same duration





# Pressure/Temperature Rating According to Asme B16.34 - 2013

**Material: ASTM A 105, ASTM A 2016 Gr.WCB, ASTM A 350 Gr. LF (Table VII - 2-1.1)**

| Temperature<br>°F (°C) | Working Pressures by Classes, psig (Bar) |          |             |             |             |             |
|------------------------|--|----------|-------------|-------------|-------------|-------------|
|                        | 150                                      | 300      | 600         | 900         | 1500        | 2500        |
| -20 TO 100 (-29 to 38) | 285 (20)                                 | 740 (51) | 1.480 (102) | 2.220 (153) | 3.705 (255) | 6.170 (425) |
| 200 (93)               | 260 (18)                                 | 680 (47) | 1.360 (94)  | 2.035 (140) | 3.395 (234) | 5.655 (390) |
| 300 (149)              | 230 (16)                                 | 655 (45) | 1.310 (90)  | 1.965 (135) | 3.270 (225) | 5.450 (376) |
| 400 (204)              | 200 (14)                                 | 635 (44) | 1.265 (87)  | 1.900 (131) | 3.170 (219) | 5.280 (364) |
| 500 (260)              | 170 (12)                                 | 605 (42) | 1.205 (83)  | 1.810 (125) | 3.015 (208) | 5.025 (346) |
| 600 (316)              | 140 (10)                                 | 570 (39) | 1.135 (78)  | 1.705 (118) | 2.840 (196) | 4.730 (326) |
| 650 (343)              | 125 (9)                                  | 550 (38) | 1.100 (76)  | 1.650 (114) | 2.745 (189) | 4.575 (315) |
| 700 (371)              | 110 (8)                                  | 530 (37) | 1.060 (73)  | 1.590 (110) | 2.665 (184) | 4.425 (305) |

**Material: ASTM A 216 Gr. WCC, ASTM A 352 Gr.LCC/LC2/LC3 (Table VII - 2-1.2)**

| Temperature<br>°F (°C) | Working Pressures by Classes, psig (Bar) |          |             |             |             |             |
|------------------------|--|----------|-------------|-------------|-------------|-------------|
|                        | 150                                      | 300      | 600         | 900         | 1500        | 2500        |
| -20 TO 100 (-29 to 38) | 290 (20)                                 | 750 (52) | 1.500 (103) | 2.250 (155) | 3.750 (259) | 6.250 (431) |
| 200 (93)               | 260 (18)                                 | 750 (52) | 1.500 (103) | 2.250 (155) | 3.750 (259) | 6.250 (431) |
| 300 (149)              | 230 (16)                                 | 730 (50) | 1.455 (100) | 2.185 (151) | 3.640 (251) | 6.070 (416) |
| 400 (204)              | 200 (14)                                 | 705 (49) | 1.405 (97)  | 2.110 (145) | 3.520 (243) | 5.865 (404) |
| 500 (260)              | 170 (12)                                 | 665 (46) | 1.330 (92)  | 1.995 (138) | 3.325 (229) | 5.540 (382) |
| 600 (316)              | 140 (10)                                 | 570 (42) | 1.210 (83)  | 1.815 (125) | 3.025 (209) | 5.040 (348) |
| 650 (343)              | 125 (9)                                  | 590 (41) | 1.175 (81)  | 1.765 (122) | 2.940 (203) | 4.905 (338) |
| 700 (371)              | 110 (8)                                  | 555 (38) | 1.110 (77)  | 1.705 (118) | 2.775 (191) | 4.630 (305) |



## Engineering Data

# Galli&Cassina Production

### Design

Galli&Cassina Plug Valves have been designed in accordance with International STD. norms. ASME B16.34 - API 599 - API 6D - API 6A - BS 5353. The stem is anti-blow-out design and incorporates three sealing system (two o-rings and one stem packing). Graphite gasket is provided to guarantee full accordance with Fire Safe API 6FA and BS 6755-Part 2 specification. Fire Safe Test Certificate is available upon request.



### Machining

Galli&Cassina's workshop machining is fully of CNC machines tools, to guarantee the maximum reliability of each designed component. Every component is designed and manufactured to conform to uniformity high standards. Coordinate measurement equipment certifies the precision of valve component to required finish tolerance.



### Assembling

Particular care is always applied at the assembling stage, to guarantee the finish product is in fully compliance with valve design.



### Testing

Valve performance are then tested in accordance with international STD norms. Every valve is pressure tested to assure the integrity of its construction before being delivered to the customer. Special testing can be designed and applied in accordance with customer's request.



### Packing

All the finished product is safely protected against any risk for damaging during the transportation by track, sea or airfreight in accordance with customer's specification.



### Shipping

Galli&Cassina shipping department is always available to deliver the goods all over the world by international forwarders (containers).





# Temperature Conversion Table

$$^{\circ}\text{C} = \frac{5}{9} (^{\circ}\text{F} - 32)$$

$$^{\circ}\text{F} = \frac{9}{5} ^{\circ}\text{C} + 32$$

| $^{\circ}\text{C}$ |        | $^{\circ}\text{F}$ | $^{\circ}\text{C}$ |      | $^{\circ}\text{F}$ |
|--------------------|--------|--------------------|--------------------|------|--------------------|
| -273.0             | -459.4 |                    | 43.3               | 110  | 230.0              |
| -268.0             | -450   |                    | 46.1               | 115  | 239.0              |
| -240.0             | -400   |                    | 48.9               | 120  | 248.0              |
| -212.0             | -350   |                    | 54.4               | 130  | 266.0              |
| -184.0             | -300   |                    | 60.0               | 140  | 284.0              |
| -157.0             | -250   | -418.0             | 65.6               | 150  | 302.0              |
| -129.0             | -200   | -328.0             | 71.1               | 160  | 320.0              |
| -101.0             | -150   | -238.0             | 76.7               | 170  | 338.0              |
| -73.0              | -100   | -148.0             | 82.2               | 180  | 356.0              |
| -45.6              | -50    | -58.0              | 87.8               | 190  | 374.0              |
| -42.8              | -45    | -49.0              | 93.3               | 200  | 392.0              |
| -40.0              | -40    | -40.0              | 98.9               | 210  | 410.0              |
| -37.2              | -35    | -31.0              | 104.4              | 220  | 428.0              |
| -34.4              | -30    | 22.0               | 110.0              | 230  | 446.0              |
| -31.7              | -25    | -13.0              | 115.6              | 240  | 464.0              |
| -28.9              | -20    | -4.0               | 121.0              | 250  | 482.0              |
| -26.1              | -15    | 5.0                | 149.0              | 300  | 572.0              |
| -23.2              | -10    | 14.0               | 177.0              | 350  | 662.0              |
| -20.6              | -5     | 23.0               | 204.0              | 400  | 752.0              |
| -17.8              | 0      | 32.0               | 232.0              | 450  | 842.0              |
| -15.0              | 5      | 41.0               | 260.0              | 500  | 932.0              |
| -12.2              | 10     | 50.0               | 288.0              | 550  | 1022.0             |
| -9.4               | 15     | 59.0               | 316.0              | 600  | 1112.0             |
| -6.7               | 20     | 68.0               | 343.0              | 650  | 1202.0             |
| -3.9               | 25     | 77.0               | 371.0              | 700  | 1292.0             |
| -1.1               | 30     | 86.0               | 399.0              | 750  | 1382.0             |
| 0                  | 32     | 89.6               | 427.0              | 800  | 1472.0             |
| 7.7                | 35     | 95.0               | 454.0              | 850  | 1562.0             |
| 4.4                | 40     | 104.0              | 482.0              | 900  | 1652.0             |
| 7.2                | 45     | 113.0              | 510.0              | 950  | 1742.0             |
| 10.0               | 50     | 122.0              | 538.0              | 1000 | 1832.0             |
| 12.8               | 55     | 131.0              | 566.0              | 1050 | 1922.0             |
| 15.6               | 60     | 140.0              | 593.0              | 1100 | 2012.0             |
| 18.3               | 65     | 149.0              | 621.0              | 1150 | 2102.0             |
| 21.1               | 70     | 158.0              | 649.0              | 1200 | 2192.0             |
| 23.9               | 75     | 167.0              | 677.0              | 1250 | 2282.0             |
| 26.7               | 80     | 176.0              | 704.0              | 1300 | 2372.0             |
| 29.4               | 85     | 185.0              | 732.0              | 1350 | 2462.0             |
| 32.2               | 90     | 194.0              | 762.0              | 1400 | 2552.0             |
| 35.0               | 95     | 203.0              | 788.0              | 1450 | 2642.0             |
| 37.8               | 100    | 212.0              | 816.0              | 1500 | 2732.0             |
| 40.6               | 105    | 221.0              |                    |      |                    |

**Note:** The temperature to be converted is the figure in the blue column.  
To obtain a reading in  $^{\circ}\text{C}$  use left column; for conversion to  $^{\circ}\text{F}$  use the right column.



# Chemical and Mechanical Requirements - Cast Materials

Composition % (Maximum Percent Unless Range is Given)

|   | ASTM Standard<br>(UNS designation) | Nominal<br>Composition | C         | Mn        | P     | S     | Si   |
|---|------------------------------------|------------------------|-----------|-----------|-------|-------|------|
| Carbon<br>Steel   | A 216 WCB (2)                      |                        | 0,30      | 1,00      | 0,035 | 0,035 | 0,60 |
|   | A 216 WCC (2)                      |                        | 0,25      | 1,20      | 0,035 | 0,035 | 0,60 |
|   | A 352 LCB (UNS J03003) (2)         |                        | 0,30      | 1,00      | 0,040 | 0,045 | 0,60 |
|   | A 352 LCC (UNS J02505) (2)         |                        | 0,25      | 1,20      | 0,040 | 0,045 | 0,60 |
|   | A 352 LC3 (UNS J31550)             | 3,5Ni                  | 0,15      | 0,50-0,80 | 0,040 | 0,045 | 0,60 |
|   | A 487 Gr4Q 4-C                     | Ni-Cr-Mo               | 0,030     | 1,00      | 0,040 | 0,045 | 0,80 |
| Low Alloy   | A 217 WC1                          | C-Mo                   | 0,25      | 0,50-0,80 | 0,040 | 0,045 | 0,60 |
|   | A 217 WC6                          | Cr-Mo                  | 0,05-0,20 | 0,50-0,80 | 0,035 | 0,035 | 0,60 |
|   | A 217 WC9                          | Cr-Mo                  | 0,05-0,18 | 0,40-0,70 | 0,035 | 0,035 | 0,60 |
|   | A 217 C5                           | Cr-Mo                  | 0,20      | 0,40-0,70 | 0,040 | 0,045 | 0,75 |
|   | A 217 C12                          | Cr-Mo                  | 0,20      | 0,35-0,65 | 0,035 | 0,035 | 1,00 |
| Martensitic   | A 217 CA15 (UNS J91150)            | 13Cr                   | 0,15      | 1,00      | 0,040 | 0,025 | 1,50 |
|   | A 487 CA6NM (UNS J91540)           | 13Cr-4Ni               | 0,060     | 1,00      | 0,040 | 0,030 | 1,00 |
| Austenitic<br>Stainless Steel                           | A 351 CF3 (UNS J92500)             | 18Cr-8Ni               | 0,030     | 1,50      | 0,040 | 0,040 | 2,00 |
|   | A 351 CF3M (UNS J92800)            | 16Cr-12Ni-2Mo          | 0,030     | 1,50      | 0,040 | 0,040 | 1,50 |
|   | A 351 CF8 (UNS J92600)             | 18Cr-8Ni               | 0,080     | 1,50      | 0,040 | 0,040 | 2,00 |
|   | A 351 CF8C (UNS 92710) (1)         | 18Cr-10Ni-2Co          | 0,080     | 1,50      | 0,040 | 0,040 | 2,00 |
|   | A 351 CF8M (UNS J92900)            | 16Cr-12Ni-2Mo          | 0,080     | 1,50      | 0,040 | 0,040 | 1,50 |
|   | A 351 CN7M (UNS N08007)            | 29Ni-20Cr-3Cu-2Mo      | 0,070     | 1,50      | 0,040 | 0,040 | 1,50 |
|   | A 351 CK3MCuN (UNS J93254) (3)     | 20Cr-18Ni-6Mo-N        | 0,025     | 1,20      | 0,045 | 0,010 | 1,00 |
| Cast Austenitic<br>Ferritic (Duplex)<br>Stainless Steel | A 890 CD3MN (UNS J92205)           | 22Cr-5Ni-Mo-N          | 0,030     | 1,50      | 0,040 | 0,020 | 1,00 |
|   | A 890 CE3MN (UNS J93404) (3)       | 25Cr-7Ni-Mo-N          | 0,030     | 1,50      | 0,040 | 0,040 | 1,00 |
|   | A 890 CD3MWCuN (UNS J93380)(3)     | 25Cr-7Ni-Mo-N          | 0,030     | 1,00      | 0,030 | 0,025 | 1,00 |

# Chemical and Mechanical Requirements Bolting Materials

|      |                      |               |           |           |       |       |           |
|------|----------------------|---------------|-----------|-----------|-------|-------|-----------|
| Stud | A 193 B7 and B7M (5) | Cr-Mo         | 0,38-0,48 | 0,75-1,0  | 0,035 | 0,040 | 0,15-0,35 |
|      | A 193 B16            | Cr-Mo-V       | 0,36-0,47 | 0,45-0,70 | 0,035 | 0,040 | 0,15-0,35 |
|      | A 193 B8M CL.2       | 18Cr-10Ni-2Mo | 0,080     | 2,00      | 0,045 | 0,030 | 1,00      |
|      | A 320 L43            | Ni-Cr-Mo      | 0,38-0,43 | 0,60-0,85 | 0,035 | 0,040 | 0,15-0,35 |
|      | A 320 L7 and L7M (5) | Cr-Mo         | 0,38-0,48 | 0,75-1,00 | 0,035 | 0,040 | 0,15-0,35 |
|      | A 453 Gr 660A        |               | 0,080     | 2,00      | 0,040 | 0,030 | 1,00      |
| Nut  | A 194 2H/2HM         | C             | min 0,40  | 1,00      | 0,040 | 0,050 | 0,40      |
|      | A 194 4              | C-Mo          | 0,40-0,50 | 0,70-0,90 | 0,035 | 0,040 | 0,15-0,35 |
|      | A 194 7/7M           | Cr-Mo         | 0,38-0,48 | 0,75-1,10 | 0,035 | 0,040 | 0,15-0,35 |
|      | A 194 8M             | 18Cr-10Ni-2Mo | 0,080     | 2,00      | 0,045 | 0,030 | 1,00      |

(1) Grade CF8C shall have a columbium content of not less than 8 times the carbon content but not over 1,00%

(2) For each reduction of 0,01% below the specified maximum carbon content, and increase of 0,04% Mn above the specified maximum will be permitted up to a maximum of: 1,28% for WCB and LCB; 1,40% for WCC and LCC.



# for Body, Plug and Cover Components

## Mechanical Properties

| Cr          | Mo        | Ni         | Cu        | V           | W                            | Tensile Strength<br>min, ksi (MPa) | Yield Strength<br>min, ksi (MPa) | Elongation<br>min% | Reduction<br>of area<br>min% |
|-------------|-----------|------------|-----------|-------------|------------------------------|------------------------------------|----------------------------------|--------------------|------------------------------|
| 0,50        | 0,20      | 0,50       | 0,30      | 0,030       | -                            | 70 (485)                           | 36 (250)                         | 22                 | 35                           |
| 0,50        | 0,20      | 0,50       | 0,30      | 0,030       | -                            | 70 (485)                           | 40 (275)                         | 22                 | 35                           |
| 0,50        | 0,20      | 0,50       | 0,30      | 0,030       | -                            | 65 (450)                           | 35 (240)                         | 24                 | 35                           |
| 0,50        | 0,20      | 0,50       | -         | 0,030       | -                            | 70 (485)                           | 40 (275)                         | 22                 | 35                           |
| -           | -         | 3,00-4,00  | -         | -           | -                            | 70 (485)                           | 40 (275)                         | 24                 | 35                           |
| 0,40-0,80   | 0,15-0,30 | 0,40-0,80  | 0,50      | 0,030       | 0,10                         | 90 (620)                           | 60 (415)                         | 18                 | 35                           |
| -           | 0,45-0,65 | 0,50       | 0,50      | -           | 0,10                         | 65 (450)                           | 35 (240)                         | 24                 | 35                           |
| 1,00-1,50   | 0,45-0,65 | 0,50       | 0,50      | -           | 0,10                         | 70 (485)                           | 40 (275)                         | 20                 | 35                           |
| 2,00-2,75   | 0,90-1,20 | 0,50       | 0,50      | -           | 0,10                         | 70 (485)                           | 40 (275)                         | 20                 | 35                           |
| 4,00-6,50   | 0,45-0,65 | 0,50       | 0,50      | -           | 0,10                         | 90 (620)                           | 60 (415)                         | 18                 | 35                           |
| 8,00-10,00  | 0,90-1,20 | 0,50       | 0,50      | -           | 0,10                         | 90 (620)                           | 60 (415)                         | 18                 | 35                           |
| 11,50-14,00 | 0,50      | 1,00       | -         | -           | -                            | 90 (620)                           | 65 (450)                         | 18                 | 30                           |
| 11,50-14,00 | 0,40-1,00 | 3,5-4,5    | 0,50      | 0,05        | 0,10                         | 100 (690)                          | 75 (515)                         | 17                 | 35                           |
| 17,00-21,00 | 0,50      | 8,00-12,00 | -         | -           | -                            | 70 (485)                           | 30 (206)                         | 35                 | -                            |
| 17,00-21,00 | 2,00-3,00 | 9,00-13,00 | -         | -           | -                            | 70 (485)                           | 30 (206)                         | 30                 | -                            |
| 18,00-21,00 | 0,50      | 8,00-11,00 | -         | -           | -                            | 70 (485)                           | 30 (206)                         | 35                 | -                            |
| 18,00-21,00 | 0,50      | 9,00-12,00 | -         | -           | -                            | 70 (485)                           | 30 (206)                         | 30                 | -                            |
| 18,00-21,00 | 2,00-3,00 | 9,00-12,00 | -         | -           | -                            | 70 (485)                           | 30 (206)                         | 30                 | -                            |
| 19,0-22,0   | 2,00-3,00 | 27,5-30,5  | 3,0-4,0   | -           | -                            | 62 (425)                           | 25 (170)                         | 35                 | -                            |
| 19,5-20,5   | 6,0-7,0   | 17,5-19,5  | 0,50-1,00 | -           | N=0,18-0,24                  | 80 (550)                           | 38 (260)                         | 35                 | -                            |
| 21,0-23,5   | 2,5-3,5   | 4,5-6,5    | 1,00      | -           | N=0,10-0,30                  | 90 (620)                           | 60 (415)                         | 25                 | -                            |
| 24,0-26,0   | 4,0-5,0   | 6,0-8,0    | -         | -           | N=0,10-0,30                  | 100 (690)                          | 75 (515)                         | 18                 | -                            |
| 24,0-26,0   | 3,0-4,0   | 6,5-8,5    | 0,5-1,0   | N=0,20-0,30 | 0,5-1,0                      | 100 (690)                          | 65 (450)                         | 25                 | -                            |
| 0,75-1,20   | 0,15-0,25 | -          | -         | -           | -                            | 125/100 (860/690)                  | 105/80 (720/550)                 | 16/18              | 50                           |
| 0,80-1,15   | 0,50-0,65 | -          | -         | 0,25-0,35   | Al=0,015                     | 125 (860)                          | 105 (725)                        | 18                 | 50                           |
| 16,0-18,0   | 2,00-3,00 | 10,0-14,0  | -         | -           | -                            | 100 (690)                          | 80 (550)                         | (4)                | 45                           |
| 0,70-0,90   | 0,20-0,30 | 1,65-2,00  | -         | -           | -                            | 125 (860)                          | 105 (725)                        | 16                 | 50                           |
| 0,80-1,10   | 0,15-0,25 | -          | -         | -           | -                            | 125/100 (860/690)                  | 105/80 (725/550)                 | 16                 | 50                           |
| 13,5-16,0   | 1,00-1,50 | 24,0-27,0  | -         | 0,10-0,50   | B=0,001-0,01<br>Ti=1,90-2,35 | 130 (895)                          | 85 (585)                         | 15                 | 18                           |
| -           | -         | -          | -         | -           | -                            | --                                 | --                               | -                  | -                            |
| -           | 0,20-0,30 | -          | -         | -           | -                            | --                                 | --                               | -                  | -                            |
| 0,75-1,20   | 0,15-0,25 | -          | -         | -           | -                            | --                                 | --                               | -                  | -                            |
| 16,0-18,0   | 2,00-3,00 | 10,0-14,0  | -         | -           | -                            | --                                 | --                               | -                  | -                            |

(3) Pitting Resistance Equivalent Number (PREN) = Cr + 3,3Mo + 16N ≤ 40.

(4) For 3/4" (M20) and under: 110/(760), 95/(655) 15; over 3/4" (M20) up to 1" (M24): 100/(690), 80/(550), 20 over 1" M24 up to 1.25" (M30) 95/(655), 65/(450), 25 over 1.25" (M30) up to 1.5" (M36): 90/(620), 50/(345), 30.

(5) For B7M and L7M grades, a minimum carbon content of 0,28% is permitted, provided that the required tensile properties are met in the section size involved.





# Flanged-End and Welding-End Plug Valves (API 6D)

Face to Face (A) and End to End (B-C) Dimension. All Dimension in Inches.

| 1<br>Inches      | Short Pattern     |                   |                   | 5<br>A            | Regular     |                   |                   | Venturi           |                   |                   | Round-Port, Full Bore |                   |                 |
|------------------|-------------------|-------------------|-------------------|-------------------|-------------|-------------------|-------------------|-------------------|-------------------|-------------------|-----------------------|-------------------|-----------------|
|                  | Raised Face       | Welding End       | Ring and Groove   |                   | Raised Face | Welding End       | Ring and Groove   | Raised Face       | Welding End       | Ring and Groove   | Raised Face           | Welding End       | Ring and Groove |
|                  | 2<br>A            | 3<br>B            | 4<br>C            | 6<br>B            | 7<br>C      | 8<br>A            | 9<br>B            | 10<br>C           | 11<br>A           | 12<br>B           | 13<br>C               |                   |                 |
| <b>CLASS 150</b> |                   |                   |                   |                   |             |                   |                   |                   |                   |                   |                       |                   |                 |
| 2                | 7                 | 10 <sup>1/2</sup> | 7 <sup>1/2</sup>  | -                 | -           | -                 | -                 | -                 | 10 <sup>1/2</sup> | -                 | 11                    |                   |                 |
| 2 <sup>1/2</sup> | 7 <sup>1/2</sup>  | 12                | 8                 | -                 | -           | -                 | -                 | -                 | 11 <sup>3/4</sup> | -                 | 12 <sup>1/4</sup>     |                   |                 |
| 3                | 8                 | 13                | 8 <sup>1/2</sup>  | -                 | -           | -                 | -                 | -                 | 13 <sup>1/2</sup> | -                 | 14                    |                   |                 |
| 4                | 9                 | 14                | 9 <sup>1/2</sup>  | -                 | -           | -                 | -                 | -                 | 17                | -                 | 17 <sup>1/2</sup>     |                   |                 |
| 6                | 10 <sup>1/2</sup> | 18                | 11                | 15 <sup>1/2</sup> | -           | 16                | -                 | -                 | 21 <sup>1/2</sup> | -                 | 22                    |                   |                 |
| 8                | 11 <sup>1/2</sup> | 20 <sup>1/2</sup> | 12                | 18                | -           | 18 <sup>1/2</sup> | -                 | -                 | 24 <sup>1/2</sup> | -                 | 25                    |                   |                 |
| 10               | 13                | 22                | 13 <sup>1/2</sup> | 21                | -           | 21 <sup>1/2</sup> | 21                | 22                | 21 <sup>1/2</sup> | 26                | -                     | 26 <sup>1/2</sup> |                 |
| 12               | 14                | 25                | 14 <sup>1/2</sup> | 24                | -           | 24 <sup>1/2</sup> | 24                | 25                | 24 <sup>1/2</sup> | 30                | -                     | 30 <sup>1/2</sup> |                 |
| 14               | -                 | -                 | -                 | -                 | -           | -                 | 27                | 27                | 27 <sup>1/2</sup> | -                 | -                     | -                 |                 |
| 16               | -                 | -                 | -                 | -                 | -           | -                 | 30                | 30                | 30 <sup>1/2</sup> | -                 | -                     | -                 |                 |
| 18               | -                 | -                 | -                 | -                 | -           | -                 | 34                | 34                | 34 <sup>1/2</sup> | -                 | -                     | -                 |                 |
| 20               | -                 | -                 | -                 | -                 | -           | -                 | 36                | 36                | 36 <sup>1/2</sup> | -                 | -                     | -                 |                 |
| 24               | -                 | -                 | -                 | -                 | -           | -                 | 42                | 42                | 42 <sup>1/2</sup> | -                 | -                     | -                 |                 |
| <b>CLASS 300</b> |                   |                   |                   |                   |             |                   |                   |                   |                   |                   |                       |                   |                 |
| 2                | 8 <sup>1/2</sup>  | 10 <sup>1/2</sup> | 9 <sup>1/8</sup>  | -                 | -           | -                 | -                 | -                 | 11 <sup>1/8</sup> | 11 <sup>1/8</sup> | 11 <sup>3/4</sup>     |                   |                 |
| 2 <sup>1/2</sup> | 9 <sup>1/2</sup>  | 12                | 10 <sup>1/8</sup> | -                 | -           | -                 | -                 | -                 | 13                | 13                | 13 <sup>5/8</sup>     |                   |                 |
| 3                | 11 <sup>1/8</sup> | 13                | 11 <sup>3/4</sup> | -                 | -           | -                 | -                 | -                 | 15 <sup>1/4</sup> | 15 <sup>1/4</sup> | 15 <sup>7/8</sup>     |                   |                 |
| 4                | 12                | 14                | 12 <sup>5/8</sup> | -                 | -           | -                 | -                 | -                 | 18                | 18                | 18 <sup>5/8</sup>     |                   |                 |
| 6                | 15 <sup>7/8</sup> | 18                | 16 <sup>1/2</sup> | 15 <sup>7/8</sup> | -           | 16 <sup>1/2</sup> | 15 <sup>7/8</sup> | 18                | 16 <sup>1/2</sup> | 22                | 22                    | 22 <sup>5/8</sup> |                 |
| 8                | 16 <sup>1/2</sup> | 20 <sup>1/2</sup> | 17 <sup>1/8</sup> | 19 <sup>3/4</sup> | -           | 20 <sup>3/8</sup> | 16 <sup>1/2</sup> | 20 <sup>1/2</sup> | 17 <sup>1/8</sup> | 27                | 27                    | 27 <sup>5/8</sup> |                 |
| 10               | 18                | 22                | 18 <sup>5/8</sup> | 22 <sup>3/8</sup> | -           | 23                | 18                | 22                | 18 <sup>5/8</sup> | 32 <sup>1/2</sup> | 32 <sup>1/2</sup>     | 33 <sup>1/8</sup> |                 |
| 12               | 19 <sup>3/4</sup> | 25                | 20 <sup>3/8</sup> | -                 | -           | -                 | 19 <sup>3/4</sup> | 25                | 20 <sup>3/8</sup> | 38                | 38                    | 38 <sup>5/8</sup> |                 |
| 14               | -                 | -                 | -                 | -                 | -           | -                 | 30                | 30                | 30 <sup>5/8</sup> | -                 | -                     | -                 |                 |
| 16               | -                 | -                 | -                 | -                 | -           | -                 | 33                | 33                | 33 <sup>5/8</sup> | -                 | -                     | -                 |                 |
| 18               | -                 | -                 | -                 | 36                | -           | 36 <sup>5/8</sup> | 36                | 36                | 36 <sup>5/8</sup> | -                 | -                     | -                 |                 |
| 20               | -                 | -                 | -                 | 39                | -           | 39 <sup>3/4</sup> | 39                | 39                | 39 <sup>3/4</sup> | -                 | -                     | -                 |                 |
| 22               | -                 | -                 | -                 | 43                | -           | 43 <sup>7/8</sup> | 43                | 43                | 43 <sup>7/8</sup> | -                 | -                     | -                 |                 |
| 24               | -                 | -                 | -                 | 45                | -           | 45 <sup>7/8</sup> | 45                | 45                | 45 <sup>7/8</sup> | -                 | -                     | -                 |                 |
| 26               | -                 | -                 | -                 | 49                | -           | 50                | 49                | 49                | 50                | -                 | -                     | -                 |                 |
| 28               | -                 | -                 | -                 | 53                | -           | 54                | 53                | 53                | 54                | -                 | -                     | -                 |                 |
| 30               | -                 | -                 | -                 | 55                | -           | 56                | 55                | 55                | 56                | -                 | -                     | -                 |                 |
| 32               | -                 | -                 | -                 | 60                | -           | 61 <sup>1/8</sup> | 60                | 60                | 61 <sup>1/8</sup> | -                 | -                     | -                 |                 |
| 34               | -                 | -                 | -                 | 64                | -           | 65 <sup>1/8</sup> | 64                | 64                | 65 <sup>1/8</sup> | -                 | -                     | -                 |                 |
| 36               | -                 | -                 | -                 | 68                | -           | 69 <sup>1/8</sup> | 68                | 68                | 69 <sup>1/8</sup> | -                 | -                     | -                 |                 |



## Qualification of other Size Valves - API 6FA

### Size of Test Valve

| NPS   | DN  | NPS   | DN                           |
|---|-----|---|------------------------------|
| 2 API 6D<br>1 <sup>13</sup> / <sub>16</sub> - 2 <sup>1</sup> / <sub>16</sub> API 6A | 50  | 2 - 2 1/2 - 3 - 4 API 6D<br>1 <sup>13</sup> / <sub>16</sub> - 2 <sup>1</sup> / <sub>16</sub> - 2 <sup>9</sup> / <sub>16</sub> - 3 <sup>1</sup> / <sub>8</sub> - 4 <sup>1</sup> / <sub>16</sub> API 6A | 50 - 65<br>80 - 100          |
| 2 <sup>9</sup> / <sub>16</sub> API 6A<br>2 1/2 API 6D                               | 65  | 2 <sup>9</sup> / <sub>16</sub> - 3 <sup>1</sup> / <sub>8</sub> - 4 <sup>1</sup> / <sub>16</sub> - 5 <sup>1</sup> / <sub>8</sub> API 6A<br>2 1/2 - 3 - 4 API 6D  | 65 - 80<br>100 - 125         |
| 3 API 6D<br>3 <sup>1</sup> / <sub>8</sub> API 6A                                    | 80  | 3 - 4 - 6 API 6D<br>3 <sup>1</sup> / <sub>8</sub> - 4 <sup>1</sup> / <sub>16</sub> - 5 <sup>1</sup> / <sub>8</sub> - 7 <sup>1</sup> / <sub>16</sub> API 6A  | 80 - 100<br>125 - 150        |
| 4 API 6D<br>4 <sup>1</sup> / <sub>16</sub> API 6A                                   | 100 | 4 - 6 - 8 API 6D<br>4 <sup>1</sup> / <sub>16</sub> - 5 <sup>1</sup> / <sub>8</sub> - 7 <sup>1</sup> / <sub>16</sub> API 6A  | 100 - 125<br>150 - 200       |
| 6 API 6D<br>7 <sup>1</sup> / <sub>16</sub> API 6A                                   | 150 | 6 - 8 - 10 - 12 API 6D<br>7 <sup>1</sup> / <sub>16</sub> - 9 - 11 API 6A  | 150 - 200<br>250 - 300       |
| 8 API 6D  | 200 | 8 - 10 - 12 - 14 - 16 API 6D<br>9 - 11 API 6A   | 200 - 250<br>300 - 350 - 400 |
| 10 API 6D   | 250 | 10 through 20 API 6D<br>11 API 6A   | 250 through<br>500           |
| 12 API 6D   | 300 | 12 through 24 API 6D  | 300 through 600              |
| 14 API 6D   | 350 | 14 through 28 API 6D  | 350 through 700              |
| 16 API 6D   | 400 | 16 and larger 24 API 6D   | 400 and larger               |

## Qualification of other Pressure Rating Valves

### Rating of Test Valve

| Class        | PN  | Bar | Class                                  | PN               | Bar                |
|--------------|-----|-----|--|------------------|--------------------|
| 150 API 6D   | 20  | N/A | 150 - 300 API 6D                       | 20 - 50          | N/A                |
| 300 API 6D   | 50  | N/A | 300 - 400 - 600 API 6D                 | 50 - 64 - 110    | N/A                |
| 400 API 6D   | 64  | N/A | 400 - 600 API 6D                       | 64 - 110         | N/A                |
| 600 API 6D   | 110 | N/A | 600 - 900 API 6D<br>2000 - 3000 API 6A | 110 - 150<br>N/A | N/A<br>138 - 207   |
| 900 API 6D   | 150 | N/A | 900 - 1500 API 6D<br>3000 API 6A       | 150 - 260<br>N/A | N/A<br>207         |
| 1500 API 6D  | 260 | N/A | 1500 - 2500 API 6D<br>5000 API 6A      | 260 - 420<br>N/A | N/A<br>345         |
| 2500 API 6D  | 420 | N/A | 2500 API 6D<br>10000 API 6A            | 420<br>N/A       | N/A<br>690         |
| 2000 API 6A  |     | 138 | 2000, 3000 API 6A<br>900, 1500 API 6D  | N/A<br>150, 260  | 138, 207<br>N/A    |
| 3000 API 6A  |     | 207 | 3000, 5000 API 6A<br>1500, 2500 API 6D | N/A<br>260, 420  | 207, 345<br>N/A    |
| 5000 API 6A  |     | 345 | 5000, 10000 API 6A<br>2500 API 6D      | N/A<br>420       | 345, 690<br>N/A    |
| 10000 API 6A |     | 690 | 10000, 15000<br>20000 API 6A           | N/A              | 690, 1034,<br>1379 |



## Lubricants

**Galli&Cassina Plug Valves can use different types of Climax lubricant grease suitable for various services.**

**The operating conditions must be specified at enquiry stage enabling us to advise which type of sealant is suitable. The lubricant grease is available as a spare part item and can be ordered as:**



- **Cartridges (suitable for hydraulic gun pump).**
  - **Drums (suitable for pneumatic pump).**
- For the selection of the correct lubricant, Galli&Cassina staff is always available at the customer's request to recommend the suitable lubricant.**

## Climax Hydraulic Gun No.1699



This specially designed, high pressure handgun, light in weight (appr. 16lbs.) is more rugged than conventional types and meets exacting demands of plug valve sealants. Built for servicing plug valves, all parts are machined with minutye accuracy.

The polished hardened steel piston is perfectly fitted in the high pressure barrel to provide absolute smoothness of operation. The CLIMAX 1699 is self-priming and can be used in any position. Because of its hydraulic principle, this gun exerts more pressure than any other portable gun.

This gun is equipped with a CLIMAX 1699 Button Head Coupler for connection to the button head sealant fitting in the shank of the valve. This coupler has a built-in feature which locks it to fitting when the gun is under positive pressure.

The coupler cannot be connected to or separated from the fitting with the gun under pressure. This pressure may be relieved by a turn of the by-pass valve on the gun. The by-pass valve should not be closed to a point where it is jammed into its seat, nor should it be opened tight against the stop.



The valve should be closed firmly, but no tightly. It is not necessary to open the valve past one full turn. Due to "built-in" safety features, the CLIMAX 1699

provides the maximum safety to both the valve and the gun itself. The hydraulic system of the gun is equipped with a relief fitting to protect

the gun from injury if the operator were to continue to pump after the gun had been depleted of valve sealant.

Also, to prevent damage to the valve and sealant gun, in the event of sealant clogging the system or the operator pumping too fast, a CLIMAX 15000 psi gauge is optional equipment.

This accessory indicates the point at which sufficient sealant pressure has been developed within the valve. The gauge also indicates valve adjustment and other services required. The CLIMAX 0-15000 psi gauge is the highest quality, most reliable glycerin filled gauge available.

The one piece die cast brass case and heavy duty bourdon tube and movement enable the gauge to stand up to the shock and vibration encountered on the most demanding applications. The CLIMAX gauge also features a rubber gauge protector.

A carrying case for the CLIMAX Model 1699 is optional. Refer to the part list for available options.

**Note:** Gun shown is a 1699-S model complete with hose assembly, gauge, tee and "Z" swivel.

## Automatic Lubrication

**Galli&Cassina Plug Valves can be provided with a special automatic lubricant pump to facilitate lubrication maintenance service. The automatic pump model depends on the size of valve and its number of open/closed cycles enables**

**us to calculate the consumption of the lubricant grease during the operating service. The automatic pumps are available either electric or pneumatic motor type at the following operating temperature range: -20 to 40°C.**



# Climax Lubricants

| Lubricant and No. | Type Available | Color      | Temp. Range From To            | Principal Services   | Unsuitable For               |
|-------------------|----------------|------------|--------------------------------|--|------------------------------|
| 220               | Stick Bulk     | Clear      | -75 to 250 °F<br>-59 to 121 °C | Very cold service for pipe lines, compressor stations, gasoline plants and crude oil production fields.<br>For Liquid Service. | Aromatic, Solvents           |
| 262               | Stick          |            | -85 to 250 °F<br>-65 to 121 °C | Same as above-Gas Service.   | LPG                          |
| 400               | Stick Bulk     | Red        | -20 to 450 °F<br>-29 to 232 °C | Acids and Caustics.  | Liquid Hydrocarbons.         |
| 600               | Stick Bulk     | Tan Brown  | -20 to 500 °F<br>-29 to 260 °C | General gas and general Hydrocarbons service.  | LPG                          |
| 650               | Stick Bulk     | Blue-Green | -40 to 500 °F<br>-40 to 260 °C | Hydrocarbon and L.P.G. service   | Aromatic, Alkalies Solvents. |
| 711               | Stick Bulk     | White      | 32 to 400 °F<br>0 to 204 °C    | Aviation gasoline, Jet fuel, fuel blends of Alkylate.  | 100% Benzine                 |
| 750               | Stick Bulk     | Black      | 0 to 600 °F<br>-18 to 316 °C   | Asphalt hot oil service Salt brine, high temperature steam.  | Aromatic, Alkalies Solvents. |
| 800               | Stick Bulk     | White      | -20 to 450 °F<br>-29 to 232 °C | Butane, Butadiene, Carbon Tetrachloride, Ethane, Propane.  | Alkalies                     |
| 900               | Stick Bulk     | Black      | -20 to 650 °F<br>-29 to 343 °C | Natural gas, petrochemical plants, rubber plants, and hot Hydrocarbons service.  | Alkalies                     |
| 901               | Stick Bulk     | Black      | -30 to 300 °F<br>-34 to 149 °C | Cold weather, Hydrocarbon lubricant.   | Alkalies                     |
| 950               | Stick Bulk     | Amber      | -40 to 300 °F<br>-40 to 149 °C | Propylenes, Benzenes Toulene, Butadiene, Xylenes, Styrene, Cumenes   | Alkalies                     |
| 1034-MT           | Stick Bulk     | Cream      | -20 to 400 °F<br>-29 to 204 °C | Liquid and gaseous. Aliphatic hydrocarbon service.<br>(Wet or dry natural gas)   | Alkalies                     |



# Quality Assurance Program

## CERTIFICATE OF APPROVAL

This is to certify that the Occupational Health & Safety Management System of:

**Galli & Cassina S.p.A.**  
Via Drizza, 30/32  
20020 Solaro (Milano) - Italy

has been approved by Lloyd's Register Quality Assurance to the following standard:

**OHSAS 18001:2007**

The Occupational Health & Safety Management System is applicable to:

**Design & manufacturing of plug valves of the after sales services, in carbon steel and exotic special alloys with DN from 1/4" up to 36" (i.e. from DN 6 to DN 900), up to class ANSI 2500 (PN 4200) and with DN from 1" 3/16 to 11" up to class API 10000 P and flow indicators and gear operators.**

Approval Certificate  
No: LRC 6017612/OHS/U/EN



## CERTIFICATE OF APPROVAL

This is to certify that the Environmental Management System of:

**Galli & Cassina S.p.A.**  
Via Drizza, 30/32  
20020 Solaro (Milano) - Italia

has been approved by Lloyd's Register Quality Assurance to the following Environmental Management System Standard:

**ISO 14001:2004**

The Environmental Management System is applicable to:

**Design & manufacturing of plug valves, including the after sales services, in carbon steel, alloy steel and exotic special alloys with DN from 1/4" up to 36" (i.e. from DN 6 to DN 900), up to class ANSI 2500 (PN 4200) and with DN from 1" 3/16 to 11" up to class API 10000 P and flow indicators and gear operators.**

Approval Certificate  
No: LRC 6017612/EMS/U/EN

Original Approval: 18<sup>th</sup> March 2014

## Certificate of Authority to use the Official API Monogram

License Number: 6A-0520

The American Petroleum Institute hereby grants to:

**GALLI & CASSINA S.P.A.**  
Via Drizza, 30/32  
Solaro, Milan  
Italy

## Certificate of Authority to use the Official API Monogram

License Number: 6D-0049.1

The American Petroleum Institute hereby grants to:

**GALLI & CASSINA S.P.A.**  
Via Drizza, 30/32  
Solaro, Milan  
Italy

the right to use the Official API Monogram<sup>®</sup> on manufactured products under the conditions in the official publications of the American Petroleum Institute entitled API Spec Q1<sup>®</sup> and API Spec 6D and in accordance with the provisions of the License Agreement.

In all cases where the Official API Monogram is applied, the API Monogram should be used in conjunction with this certificate number: 6D-0049.1

The American Petroleum Institute reserves the right to revoke this authorization to use the Official API Monogram for any reason satisfactory to the Board of Directors of the American Petroleum Institute.

The scope of this license includes the following product: Plug Valves  
QMS Exclusions: No Exclusions Identified as Applicable

manufactured products under the conditions in the official publications of the American Petroleum Institute entitled API Spec Q1<sup>®</sup> and API Spec 6A and in accordance with the provisions of the License Agreement.

the API Monogram should be used in conjunction with this authorization to use the Official API Monogram and in accordance with the provisions of the License Agreement.

Valves at PSL 1 through 4

American Petroleum Institute  
*John Madala*  
Director of Training and Certification Programs



## Quality Assurance System

After 95 years of manufacturing experience and latest technology, **Galli&Cassina** Quality Assurance System has been assessed, approved and certified against the following quality assurance standards: ISO 9001-2008 and API Q1. Rigorous procedures and internal audits guarantee that the Quality System is implemented at all stages, starting from incoming raw materials, production, inspection, assembly, final test, packing and shipping.

Every product is designed and manufactured to conform to uniformly high standards. These standards are assured by a quality management system which includes ISO 9001 certification and testing of all products prior to shipment. Advanced design, durable construction materials and rigid manufacturing standard provide valves you can rely on for years of trouble-free performance. Since its beginning in

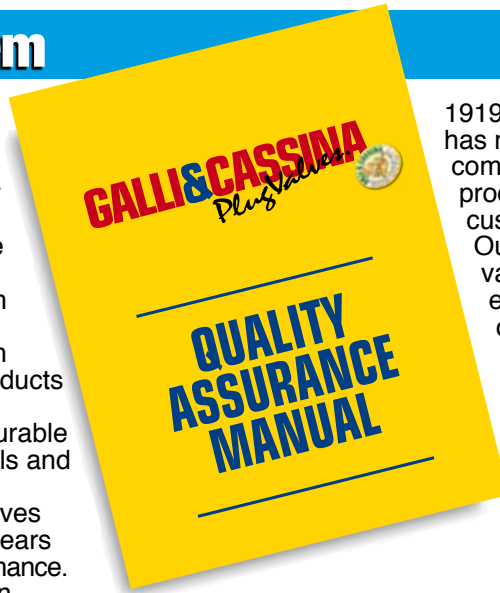

1919, **Galli&Cassina** has maintained its commitment to quality product and satisfied customers. Our focus on product variety, technical expertise and company support remains constant, from drawing board to user satisfaction, our commitment is continuous.

## Quality Assurance Development

**Galli&Cassina's** Quality Assurance System ISO 9001-2008 - HSE ISO 14001 & ISO 18001 have been assessed, approved and certified by Lloyd's Register, while the API 6D and API 6A monograms have been certified by API (American Petroleum Institute): all the certificates are the result of **Galli&Cassina's** dedication towards the aim of good reputation in the world-wide valve market, since 95 years.

In addition **Galli&Cassina** Plug Valves are in compliance with CE Pressure Equipment Directive PED N. 97/23/EC and ATEX (N. 94/9/EC) for products intended for use in potentially explosive atmospheres.



## Customer Service

**Galli&Cassina's** Customer Service is always willing to assist the customer with a prompt response to "service" requests. Full after sales services assistance can be offered either at our workshop or on site, spare parts supply. Training programs, on operation and safety.

**Cina - UAE - Kuwait  
Saudi Arabia - Europe  
India - U.S.A - Canada  
Venezuela - Colombia  
Brasil.**







## The Production Range



**Jacketed Body**

**Two Way  
Standard Type**

**Multiport Three-Four Way**

## Actuators Availability



**Electric**

**Pneumatic**

**Electro Hydraulic**

**Gas Overoil**





# History

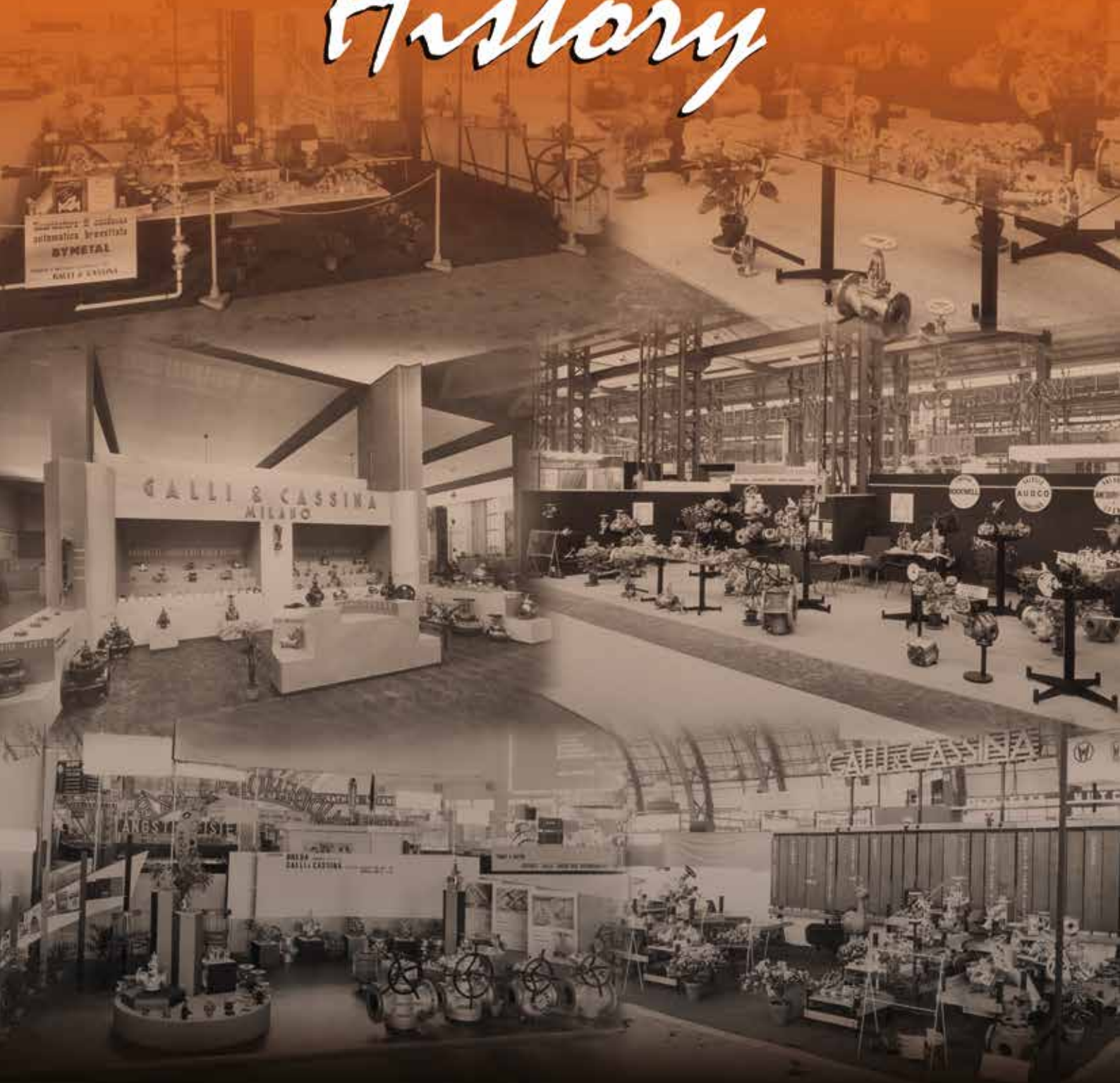

**GALLI & CASSINA**  
*Plus Valves*  
**SINCE 1919**









## **GALLI&CASSINA in the World:**

**Our products are being used in the most important Plants and Gas Pipelines all over the world.**

*Galli&Cassina Plug Valves are used in the most important hydrocarbon plants and gas pipelines all over the world.*

*For over 70 years Galli&Cassina has been committed to provide service to the end-users with a full range of products ensuring total customer's satisfaction.*

*Galli&Cassina is represented by sales offices worldwide and you are requested to contact our main office in Italy for more details.*





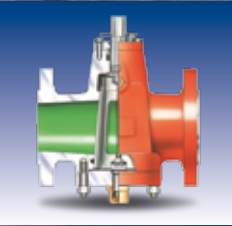
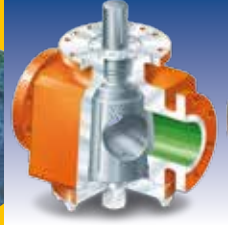
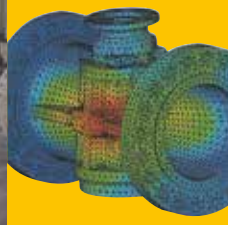

AdverTime-MI

G&C B10-2014



Global Supply Line - Australian stockist,  
distributing Worldwide.

Contact us: [sales@globalsupplyline.com.au](mailto:sales@globalsupplyline.com.au)  
Website: [www.globalsupplyline.com.au](http://www.globalsupplyline.com.au)



**Office and Workshop:**

**GALLI&CASSINA S.p.A.**  
Via Drizza, 30/32 • 20020 SOLARO (MILANO) Italy  
Phone: + 39.02.96799632/3 • Telefax: + 39.02.96799699  
<http://www.gallicassina.it> • E-mail: [valves@gallicassina.it](mailto:valves@gallicassina.it)

