

"Y"-PATTERN GLOBE VALVES



Low operation torque design.

Rising and rotating stem for the most API 602 design simplicity.

Outside Screw and Yoke (OS&Y).

Flanged valves are provided with flanges integral with the body forgings.

Standard construction of body-bonnet connections is welded bonnet type. Bolted bonnet is available as alternative construction.

Full die forged structure for all pressure containing parts.

Pattern designed to reduce the flow resistance of the valve to a minimum.

Self aligning two piece packing gland.

The connection wire secures the disc to the stem, the disc can swivel in order to guarantee the complete contact between the disc and seats surfaces.

High quality packing for reliable tightness and low emission performance.

Back-seat design.

High flow capacity port sizes and disc retraction to minimize flow velocities and maximize valve service life.

Body-guided disc for perfect seat and disc alignment. Disc is machined to the tightest tolerances to ensure trouble free shutoff and cycling.

Standard seat design is integral type, screwed-in type is available as alternative construction or in case of bolted bonnet design. Extra thickness of the seat ring provides sufficient material to renew the seating surface over and over again.

GLOBE "Y"-PATTERN VALVE DESCRIPTION

Globe valves are used for flow regulation, frequent operation, increased flow resistance or for positive shutoff when closed. Globe valves are closing-down valves in which the closure member is moved squarely on and off the seat. By this mode of disc travel, the seat opening varies in direct proportion to the travel of the disc. This proportional relationship between valve opening and disc travel is ideally suited for duties involving regulation of flow rate. Globe valves can also be used for on-off duty, the seating load can be positively controlled with high sealing capacity. The change in direction of fluid flow through these valves produces increased resistance and pressure drop. The oblique pattern globe-valve body is designed to reduce the flow resistance of the valve to a minimum. This valve combines low flow resistance for on-off duty with the robustness of globe-valve seatings. Globe valves are used in many industrial applications including the oil and gas industry, pharmaceutical, manufacturing, automotive, and marine. Globe valves are also recommended for services requiring frequent operation and positive shutoff.

P&ID SYMBOL

















STANDARD CONFIGURATIONS



Global Supply Line Australia are a major Bonney Forge distributor & stockist, supplying worldwide. Full stock list on line www.globalsupplyline.com.au Contact email: sales@globalsupplyline.com.au

SECTION INDEX OF "Y"-PATTERN GLOBE VALVES

PAGE	DESCRIPTION	SYM
D-3	BOLTED BONNET GLOBE VALVES BASIC CONFIGURATION	
	THREADED AND SOCKET WELD ENDS	
D-4	BOLTED BONNET GLOBE VALVES BASIC CONFIGURATION	
	ASME INTEGRAL FLANGED ENDS	
D-5	BOLTED BONNET GLOBE VALVES CRYOGENIC CONFIGURATION	
	THREADED AND SOCKET WELD ENDS	
D-6	BOLTED BONNET GLOBE VALVES CRYOGENIC CONFIGURATION	
	ASME INTEGRAL FLANGED ENDS	
D-7	BOLTED BONNET GLOBE VALVES BELLOW SEAL CONFIGURATION	
	THREADED AND SOCKET WELD ENDS	
D-8	BOLTED BONNET GLOBE VALVES BELLOW SEAL CONFIGURATION	
	ASME INTEGRAL FLANGED ENDS	

PAGE	DESCRIPTION	SYM
D-9	WELDED BONNET GLOBE VALVES BASIC CONFIGURATION	
	THREADED AND SOCKET WELD ENDS	
D-10	WELDED BONNET GLOBE VALVES BASIC CONFIGURATION	
	ASME INTEGRAL FLANGED ENDS	
D-11	WELDED BONNET GLOBE VALVES CRYOGENIC CONFIGURATION	
	THREADED AND SOCKET WELD ENDS	
D-12	WELDED BONNET GLOBE VALVES CRYOGENIC CONFIGURATION	
	ASME INTEGRAL FLANGED ENDS	
D-13	WELDED BONNET GLOBE VALVES BELLOW SEAL CONFIGURATION	
	THREADED AND SOCKET WELD ENDS	
D-14	WELDED BONNET GLOBE VALVES BELLOW SEAL CONFIGURATION	
	ASME INTEGRAL FLANGED ENDS	
D-15	AVAILABLE OPTIONS FOR "Y" PATTERN GLOBE VALVES	



Global Supply Line Australia major Bonney Forge distributor & stockist, supplying world wide.
Full stock list online www.globalsupplyline.com.au

Contact email: sales@globalsupplyline.com.au

APPLICABLE STANDARDS	
DESIGN	API 602 - ISO 15761 - ASME B16.34
INSPECTION & TESTING	API 598
MARKING	MSS SP-25
RATING	ASME B16.34
FUGITIVE EMISSION	API 624 - ISO 15848

"Y"-PATTERN GLOBE VALVES

BOLTED BONNET GLOBE VALVES BASIC CONFIGURATION THREADED AND SOCKET WELD ENDS



WORKING PRESSURE RATING	SIZE		STANDARD DESIGN TYPE	A		B		C		H		WEIGHT		FIGURE
	NPS	DN		mm	in	mm	in	mm	in	mm	in	kg	lb	
ASME 800	1/4"	6	S1	85	3.35	7	0.28	88	3.5	191	7.5	2.1	4.6	YH 301
	3/8"	10	S1	85	3.35	9	0.35	88	3.5	191	7.5	2.1	4.6	YH 302
	1/2"	15	S1	152.5	6.00	13	0.51	88	3.5	191	7.5	2.1	4.6	YH 303
	3/4"	20	S1	115	4.53	17	0.67	97	3.8	237	9.3	3.5	7.6	YH 304
	1"	25	S1	135	5.31	22	0.87	138	5.4	281	11.0	5.3	11.6	YH 305
	1-1/4"	32	S1	165	6.50	29	1.14	172	6.8	281	11.0	11.6	25.5	YH 306
	1-1/2"	40	S1	229	9.02	35	1.38	172	6.8	350	13.8	11.6	25.5	YH 307
	2"	50	S1	190	7.50	45	1.77	172	6.8	413	16.2	15.8	34.7	YH 308
ASME 1500	1/4"	6	S1	85	3.35	7	0.28	88	3.5	193	7.6	2.1	4.6	9YH 301
	3/8"	10	S1	85	3.35	9	0.35	88	3.5	193	7.6	2.1	4.6	9YH 302
	1/2"	15	S1	115	4.53	12	0.47	97	3.8	237	9.3	3.7	8.1	9YH 303
	3/4"	20	S1	135	5.31	15	0.59	138	5.4	281	11.0	5.6	12.3	9YH 304
	1"	25	S1	220	8.66	20	0.79	138	5.4	308	12.1	11.6	25.5	9YH 305
	1-1/4"	32	S1	165	6.50	27	1.06	172	6.8	347	13.6	11.6	25.5	9YH 306
	1-1/2"	40	S1	245	9.65	32	1.26	172	6.8	418	16.5	17.3	38.2	9YH 307
	2"	50	S1	230	9.06	40	1.57	234	9.2	495	19.5	27.3	60.2	9YH 308
ASME 2500	1/4"	6	S2	85	3.35	7	0.28	88	3.5	242	9.5	3.7	8.1	25YHR 301
	3/8"	10	S2	85	3.35	9	0.35	88	3.5	242	9.5	3.7	8.1	25YHR 302
	1/2"	15	S2	115	4.53	11	0.43	138	5.4	264	10.4	5.3	11.6	25YHR 303
	3/4"	20	S2	145	5.71	15	0.59	138	5.4	303	11.9	12.1	26.6	25YHR 304
	1"	25	S2	210	8.27	19	0.75	172	6.8	341	13.4	13.1	28.9	25YHR 305
	1-1/4"	32	S2	165	6.50	26	1.02	172	6.8	341	13.4	13.1	28.9	25YHR 306
	1-1/2"	40	S2	230	9.06	29	1.14	234	9.2	396	15.6	17.9	39.4	25YHR 307
	2"	50	S2	220	8.66	38	1.50	320	12.6	484	19.1	27.3	60.2	25YHR 308

FULL BORE

BFE reserves the right to change designs, dimensions or specifications without notice.

PRODUCT FEATURES:

- Outside Screw and Yoke (OS&Y).
- Self aligning two piece packing gland.
- Integral backseat.

DESIGN TYPE S1 SPIRAL WOUND GASKET BODY-BONNET CONNECTION

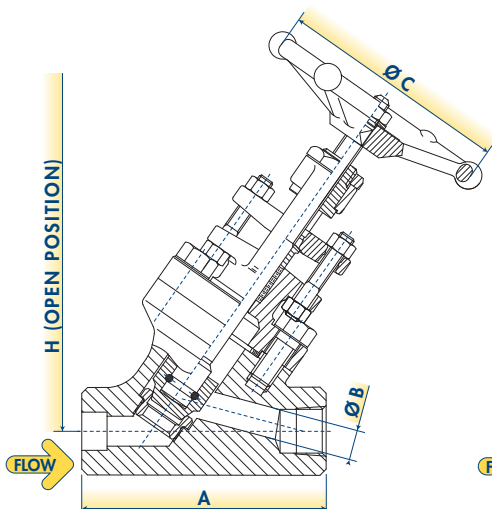

DESIGN TYPE S2 RING JOINT BODY-BONNET CONNECTION

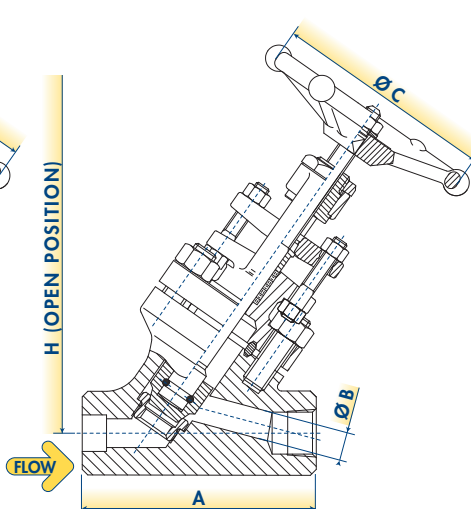

OTHER END CONNECTION TYPES AVAILABLE

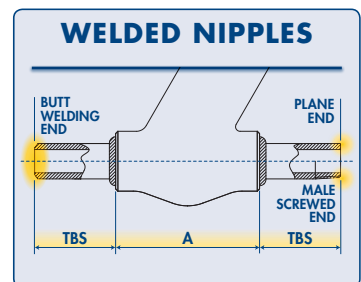
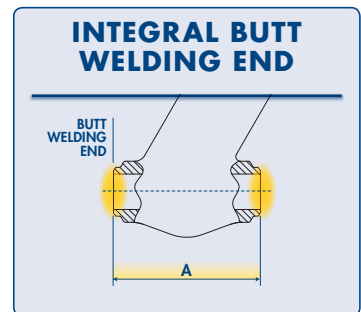

"Y"-PATTERN GLOBE VALVES

BOLTED BONNET GLOBE VALVES BASIC CONFIGURATION ASME INTEGRAL FLANGED ENDS



WORKING PRESSURE RATING	SIZE		STANDARD DESIGN TYPE	A-RF		A-RJ		B		C		H		WEIGHT		FIGURE
	NPS	DN		mm	in	mm	in	mm	in	mm	in	mm	in	kg	lb	
ASME 150 (SEE NOTE 1)	1/2"	15	S1	152.5 ⁽¹⁾	6.00	N.A.	N.A.	13	0.51	88	3.5	216	8.5	4.0	8.8	1YH 303
	3/4"	20	S1	178 ⁽¹⁾	7.01	N.A.	N.A.	17.5	0.69	97	3.8	253	10.0	6.7	14.8	1YH 304
	1"	25	S1	203 ⁽¹⁾	7.99	216 ⁽¹⁾	8.49	22.5	0.89	138	5.4	295	11.6	9.1	20.1	1YH 305
	1-1/2"	40	S1	229 ⁽¹⁾	9.02	241 ⁽¹⁾	9.52	35	1.38	172	6.8	347	13.6	17.3	38.2	1YH 307
	2"	50	S1	267 ⁽¹⁾	10.51	282.5 ⁽¹⁾	11.13	45	1.77	172	6.8	369	14.5	26.3	57.9	1YH 308
ASME 300	1/2"	15	S1	152.5	6.00	163.5	6.44	13	0.51	88	3.5	216	8.5	4.3	9.5	3YH 303
	3/4"	20	S1	178	7.01	190.5	7.51	17.5	0.69	97	3.8	253	10.0	7.4	16.2	3YH 304
	1"	25	S1	203	7.99	216	8.49	22.5	0.89	138	5.4	295	11.6	10.2	22.5	3YH 305
	1-1/2"	40	S1	229	9.02	241	9.52	35	1.38	172	6.8	347	13.6	19.4	42.8	3YH 307
	2"	50	S1	267	10.51	282.5	11.13	45	1.77	172	6.8	369	14.5	29.4	64.8	3YH 308
ASME 600	1/2"	15	S1	165	6.50	163.5	6.44	13	0.51	88	3.5	216	8.5	6.2	13.7	6YH 303
	3/4"	20	S1	191	7.52	190.5	7.52	17.5	0.69	97	3.8	253	10.0	8.4	18.5	6YH 304
	1"	25	S1	216	8.50	216	8.50	22.5	0.89	138	5.4	295	11.6	11.0	24.3	6YH 305
	1-1/2"	40	S1	241	9.49	241	9.49	35	1.38	172	6.8	347	13.6	20.5	45.1	6YH 307
	2"	50	S1	292	11.50	295	11.62	45	1.77	172	6.8	407	16.0	29.9	66.0	6YH 308
ASME 1500	1/2"	15	S1	216	8.50	216	8.50	12	0.47	97	3.8	264	10.4	8.9	19.7	15YHF 303
	3/4"	20	S1	229	9.02	229	9.02	14.5	0.57	138	5.4	308	12.1	13.5	29.9	15YHF 304
	1"	25	S1	254	10.00	254	10.00	19	0.75	172	6.8	325	12.8	17.9	39.4	15YHF 305
	1-1/2"	40	S1	305	12.01	305	12.01	31	1.22	172	6.8	407	16.0	31.5	69.4	15YHF 307
	2"	50	S1	368	14.49	371.5	14.61	38	1.50	234	9.2	512	20.1	60.9	134.3	15YHF 308
ASME 2500	1/2"	15	S2	264	10.39	264	10.39	11	0.43	138	5.4	341	13.4	17.3	38.2	25YRF 303
	3/4"	20	S2	273	10.75	273	10.75	14.5	0.57	138	5.4	347	13.6	19.4	42.8	25YRF 304
	1"	25	S2	308	12.13	308	12.13	19	0.75	172	6.8	385	15.2	31.5	69.4	25YRF 305
	1-1/2"	40	S2	384	15.12	387	15.24	28	1.10	234	9.2	495	19.5	64.6	142.4	25YRF 307
	2"	50	S2	451	17.76	454	17.88	38	1.50	320	12.6	506	19.9	70.4	155.1	25YRF 308

FULL BORE

BFE reserves the right to change designs, dimensions or specifications without notice.

PRODUCT FEATURES:

- Outside Screw and Yoke (OS&Y).
 - Self aligning two piece packing gland.
 - Integral backseat.
 - Integral body flanges.
- NOTE 1: Face-to-Face acc. to ASME B16.10 related to class 300.

DESIGN TYPE S1

SPIRAL WOUND GASKET BODY-BONNET CONNECTION

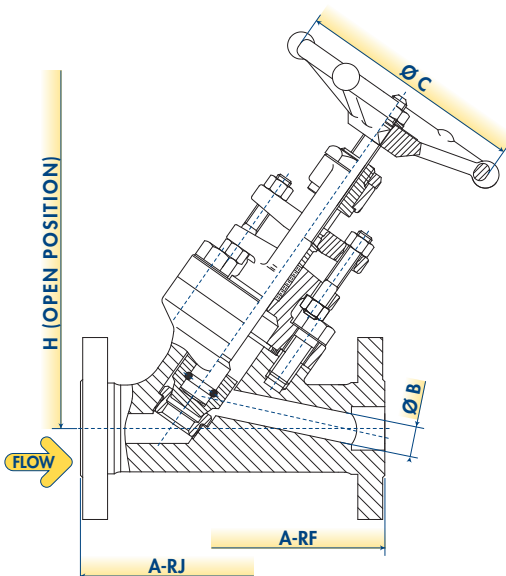

DESIGN TYPE S2

RING JOINT BODY-BONNET CONNECTION

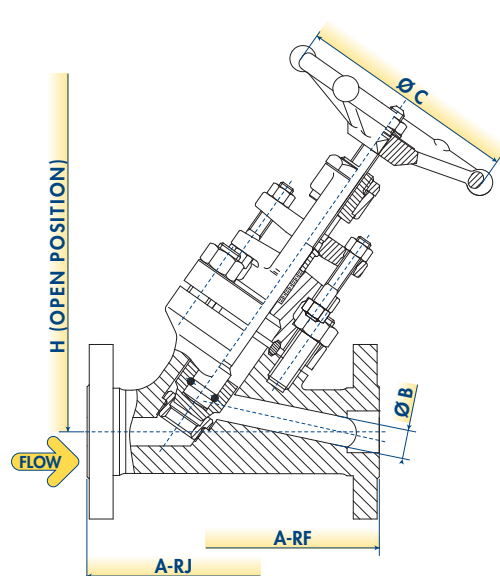

"Y"-PATTERN GLOBE VALVES

BOLTED BONNET GLOBE VALVES CRYOGENIC CONFIGURATION THREADED AND SOCKET WELD ENDS



WORKING PRESSURE RATING	SIZE		STANDARD DESIGN TYPE	A		B		C		H		WEIGHT		FIGURE
	NPS	DN		mm	in	mm	in	mm	in	mm	in	kg	lb	
ASME 800	1/4"	6	S1	85	3.35	7	0.28	88	3.5	466	18.4	3.7	8.1	CYH 301
	3/8"	10	S1	85	3.35	9	0.35	88	3.5	466	18.4	3.7	8.1	CYH 302
	1/2"	15	S1	152.5	6.00	13	0.51	88	3.5	466	18.4	3.8	8.3	CYH 303
	3/4"	20	S1	115	4.53	17	0.67	97	3.8	512	20.1	5.4	11.8	CYH 304
	1"	25	S1	135	5.31	22	0.87	138	5.4	556	21.9	8.8	19.4	CYH 305
	1-1/4"	32	S1	165	6.50	29	1.14	172	6.8	556	21.9	13.2	29.2	CYH 306
	1-1/2"	40	S1	229	9.02	35	1.38	172	6.8	625	24.6	17.3	38.2	CYH 307
	2"	50	S1	190	7.50	45	1.77	172	6.8	688	27.1	25.2	55.6	CYH 308
ASME 1500	1/4"	6	S1	85	3.35	7	0.28	88	3.5	468	18.4	4.2	9.3	9CYH 301
	3/8"	10	S1	85	3.35	9	0.35	88	3.5	468	18.4	4.2	9.3	9CYH 302
	1/2"	15	S1	115	4.53	12	0.47	97	3.8	512	20.1	5.8	12.7	9CYH 303
	3/4"	20	S1	135	5.31	15	0.59	138	5.4	556	21.9	8.4	18.5	9CYH 304
	1"	25	S1	220	8.66	20	0.79	138	5.4	583	23.0	11.6	25.5	9CYH 305
	1-1/4"	32	S1	165	6.50	27	1.06	172	6.8	622	24.5	16.3	35.9	9CYH 306
	1-1/2"	40	S1	245	9.65	32	1.26	172	6.8	693	27.3	26.3	57.9	9CYH 307
	2"	50	S1	230	9.06	40	1.57	234	9.2	770	30.3	43.1	94.9	9CYH 308
ASME 2500	1/4"	6	S2	85	3.35	7	0.28	88	3.5	517	20.4	5.8	12.7	25CYHR 301
	3/8"	10	S2	85	3.35	9	0.35	88	3.5	517	20.4	8.4	18.5	25CYHR 302
	1/2"	15	S2	115	4.53	11	0.43	138	5.4	539	21.2	13.1	28.9	25CYHR 303
	3/4"	20	S2	145	5.71	15	0.59	138	5.4	578	22.7	13.1	28.9	25CYHR 304
	1"	25	S2	210	8.27	19	0.75	172	6.8	616	24.3	27.3	60.2	25CYHR 305
	1-1/4"	32	S2	165	6.50	26	1.02	172	6.8	616	24.3	33.6	74.1	25CYHR 306
	1-1/2"	40	S2	230	9.06	29	1.14	234	9.2	671	26.4	46.2	101.9	25CYHR 307
	2"	50	S2	220	8.66	38	1.50	320	12.6	759	29.9	46.2	101.9	25CYHR 308

FULL BORE

BFE reserves the right to change designs, dimensions or specifications without notice.

PRODUCT FEATURES:

- Outside Screw and Yoke (OS&Y).
- Self aligning two piece packing gland.
- Integral backseat.

DESIGN TYPE S1 SPIRAL WOUND GASKET BODY-BONNET CONNECTION

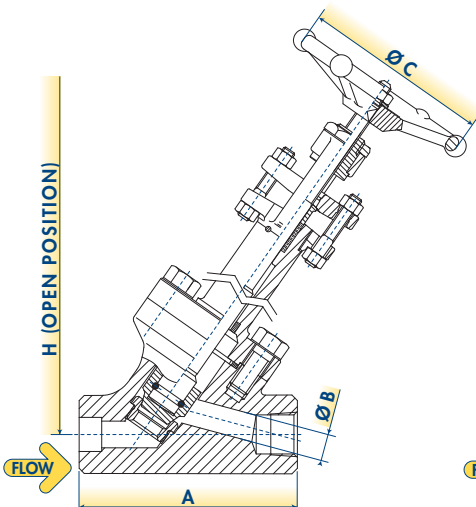

DESIGN TYPE S2 RING JOINT BODY-BONNET CONNECTION

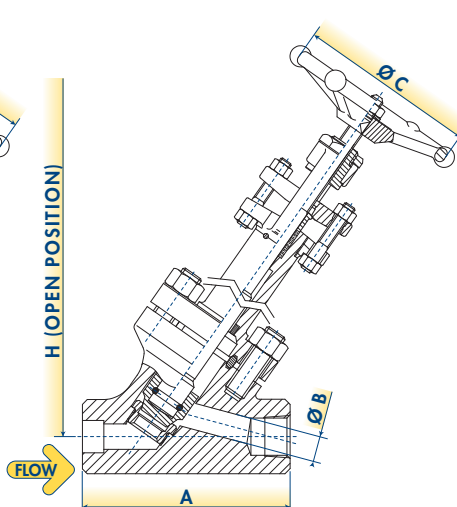

OTHER END CONNECTION TYPES AVAILABLE

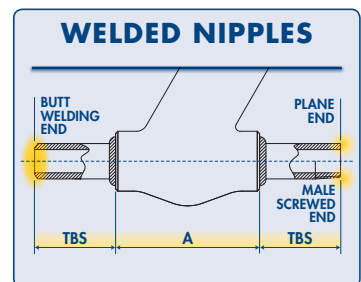
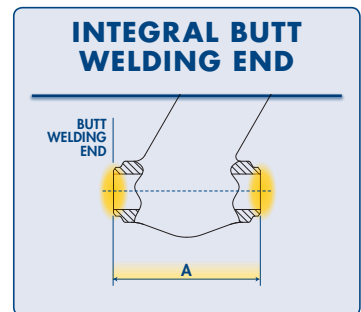

"Y"-PATTERN GLOBE VALVES

BOLTED BONNET GLOBE VALVES CRYOGENIC CONFIGURATION ASME INTEGRAL FLANGED ENDS



WORKING PRESSURE RATING	SIZE		STANDARD DESIGN TYPE	A-RF		A-RJ		B		C		H		WEIGHT		FIGURE
	NPS	DN		mm	in	mm	in	mm	in	mm	in	mm	in	kg	lb	
ASME 150 (SEE NOTE 1)	1/2"	15	S1	152.5 ⁽¹⁾	6.00	N.A.	N.A.	13	0.51	88	3.5	495	19.5	5.0	11.1	1CYH 303
	3/4"	20	S1	178 ⁽¹⁾	7.01	N.A.	N.A.	17.5	0.69	97	3.8	532	21.0	7.4	16.2	1CYH-304
	1"	25	S1	203 ⁽¹⁾	7.99	216 ⁽¹⁾	8.49	22.5	0.89	138	5.4	574	22.6	10.0	22.0	1CYH-305
	1-1/2"	40	S1	229 ⁽¹⁾	9.02	241 ⁽¹⁾	9.52	35	1.38	172	6.8	626	24.6	18.9	41.7	1CYH-307
	2"	50	S1	267 ⁽¹⁾	10.51	282.5 ⁽¹⁾	11.13	45	1.77	172	6.8	648	25.5	28.4	62.5	1CYH-308
ASME 300	1/2"	15	S1	152.5	6.00	163.5	6.44	13	0.51	88	3.5	495	19.5	6.5	14.4	3CYH-303
	3/4"	20	S1	178	7.01	190.5	7.51	17.5	0.69	97	3.8	532	21.0	8.3	18.3	3CYH-304
	1"	25	S1	203	7.99	216	8.49	22.5	0.89	138	5.4	574	22.6	12.6	27.8	3CYH-305
	1-1/2"	40	S1	229	9.02	241	9.52	35	1.38	172	6.8	626	24.6	22.1	48.6	3CYH-307
	2"	50	S1	267	10.51	282.5	11.13	45	1.77	172	6.8	648	25.5	32.6	71.8	3CYH-308
ASME 600	1/2"	15	S1	165	6.50	163.5	6.44	13	0.51	88	3.5	495	19.5	6.8	15.0	6CYH-303
	3/4"	20	S1	191	7.52	190.5	7.52	17.5	0.69	97	3.8	532	21.0	9.1	20.1	6CYH-304
	1"	25	S1	216	8.50	216	8.50	22.5	0.89	138	5.4	574	22.6	13.2	29.2	6CYH-305
	1-1/2"	40	S1	241	9.49	241	9.49	35	1.38	172	6.8	626	24.6	23.1	50.9	6CYH-307
	2"	50	S1	292	11.50	295	11.62	45	1.77	172	6.8	686	27.0	35.7	78.7	6CYH-308
ASME 1500	1/2"	15	S1	216	8.50	216	8.50	12	0.47	97	3.8	543	21.4	12.6	27.8	15CYHF 303
	3/4"	20	S1	229	9.02	229	9.02	14.5	0.57	138	5.4	587	23.1	15.2	33.6	15CYHF 304
	1"	25	S1	254	10.00	254	10.00	19	0.75	172	6.8	604	23.8	20.0	44.0	15CYHF 305
	1-1/2"	40	S1	305	12.01	305	12.01	31	1.22	172	6.8	686	27.0	32.6	71.8	15CYHF 307
	2"	50	S1	368	14.49	371.5	14.61	38	1.50	234	9.2	791	31.1	63.0	138.9	15CYHF 308
ASME 2500	1/2"	15	S2	264	10.39	264	10.39	11	0.43	138	5.4	620	24.4	18.9	41.7	25CYRF 303
	3/4"	20	S2	273	10.75	273	10.75	14.5	0.57	138	5.4	626	24.6	22.4	49.3	25CYRF 304
	1"	25	S2	308	12.13	308	12.13	19	0.75	172	6.8	664	26.2	34.7	76.4	25CYRF 305
	1-1/2"	40	S2	384	15.12	387	15.24	28	1.10	234	9.2	774	30.5	67.7	149.3	25CYRF 307
	2"	50	S2	451	17.76	454	17.88	38	1.50	320	12.6	785	30.9	74.6	164.4	25CYRF 308

FULL BORE

BFE reserves the right to change designs, dimensions or specifications without notice.

PRODUCT FEATURES:

- Outside Screw and Yoke (OS&Y).
- Self aligning two piece packing gland.
- Integral backseat.
- Integral body flanges.
- Bonnet Extension.

NOTE 1: Face-to-Face acc.to ASME B16.10 related to class 300.

DESIGN TYPE S1

**SPIRAL WOUND GASKET
BODY-BONNET CONNECTION**

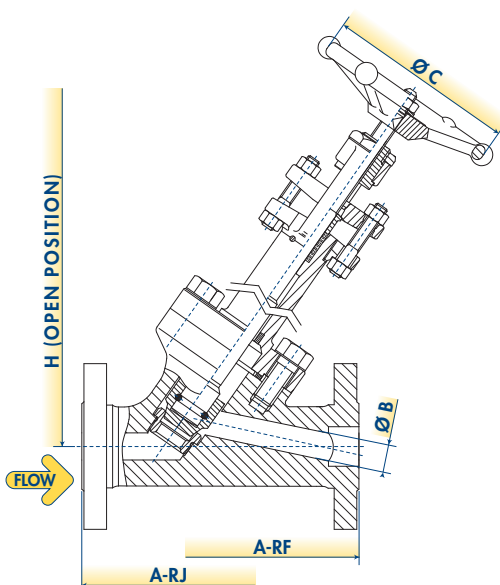

DESIGN TYPE S2

**RING JOINT
BODY-BONNET CONNECTION**

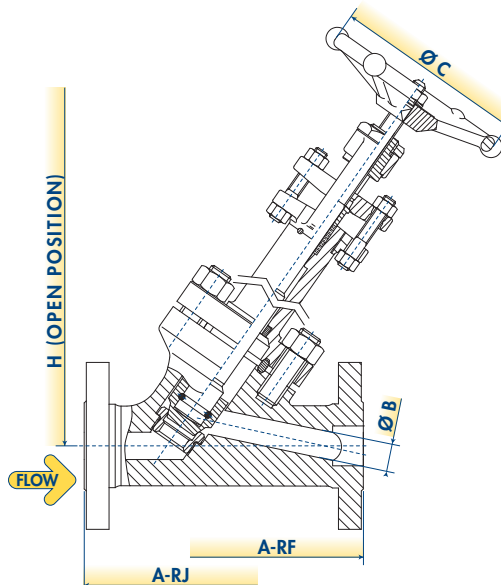

"Y"-PATTERN GLOBE VALVES

BOLTED BONNET GLOBE VALVES BELLOW SEAL CONFIGURATION THREADED AND SOCKET WELD ENDS



WORKING PRESSURE RATING	SIZE		STANDARD DESIGN TYPE	A		B		C		H		WEIGHT		FIGURE
	NPS	DN		mm	in	mm	in	mm	in	mm	in	kg	lb	
ASME 800	1/4"	6	P4	85	3.35	7	0.28	88	3.5	209	8.2	2.6	5.8	SYH 301
	3/8"	10	P4	85	3.35	9	0.35	88	3.5	209	8.2	2.6	5.8	SYH 302
	1/2"	15	P4	152.5	6.00	13	0.51	88	3.5	215	8.4	3.7	8.1	SYH 303
	3/4"	20	P4	115	4.53	17	0.67	97	3.8	248	9.7	5.5	12.0	SYH 304
	1"	25	P4	135	5.31	22	0.87	138	5.4	298	11.7	9.1	20.1	SYH 305
	1-1/4"	32	P4	165	6.50	29	1.14	138	5.4	347	13.6	10.5	23.1	SYH 306
	1-1/2"	40	P4	229	9.02	35	1.38	172	6.8	392	15.4	19.4	42.8	SYH 307
2"	50	P4	190	7.50	45	1.77	172	6.8	472	18.6	32.0	70.6	SYH 308	
ASME 1500	1/4"	6	P4	85	3.54	7	0.28	88	3.5	253	10.0	3.7	5.7	9SYH 301
	3/8"	10	P4	85	3.54	9	0.35	88	3.5	253	10.0	3.7	5.7	9SYH 302
	1/2"	15	P4	115	4.53	12	0.47	138	5.4	267	10.5	4.7	10.4	9SYH 303
	3/4"	20	P4	135	5.31	15	0.59	172	6.8	315	12.4	7.4	16.2	9SYH 304
	1"	25	P4	220	8.66	20	0.79	234	9.2	342	13.5	9.5	20.8	9SYH 305
	1-1/4"	32	P4	165	7.09	27	1.06	234	6.8	440	17.3	14.2	27.6	9SYH 306
	1-1/2"	40	P4	245	9.65	32	1.26	320	12.6	490	19.3	24.2	53.2	9SYH 307
2"	50	P4	230	9.06	40	1.57	320	12.6	561	22.1	39.9	88.0	9SYH 308	
ASME 2500	1/4"	6	P5	85	3.35	7	0.28	138	5.4	275	10.8	4.2	9.3	25SYR 301
	3/8"	10	P5	85	3.35	9	0.35	138	5.4	341	13.4	7.4	16.2	25SYR 302
	1/2"	15	P5	115	4.53	11	0.43	172	6.8	407	16.0	12.6	27.8	25SYR 303
	3/4"	20	P5	145	5.71	15	0.59	234	9.2	440	17.3	12.6	27.8	25SYR 304
	1"	25	P5	210	8.27	19	0.75	320	12.6	484	19.1	28.4	62.5	25SYR 305
	1-1/4"	32	P5	165	6.50	26	1.02	320	12.6	517	20.4	36.8	81.0	25SYR 306
	1-1/2"	40	P5	230	9.06	29	1.14	320	12.6	539	21.2	44.1	97.2	25SYR 307
	2"	50	P6	220	8.66	38	1.50	400	15.7	616	24.3	46.2	101.9	25SYR 308

FULL BORE

BFE reserves the right to change designs, dimensions or specifications without notice.

PRODUCT FEATURES:

- Outside Screw and Yoke (OS&Y).
- Self aligning two piece packing gland.
- Integral backseat.

DESIGN TYPE P4
HANDWHEEL OPERATED
& SPIRAL WOUND
GASKET BODY-BONNET
CONNECTION

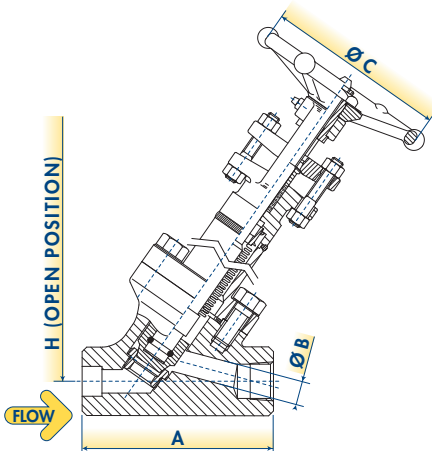

DESIGN TYPE P5
HANDWHEEL OPERATED
WITH THRUST BEARINGS
& RING JOINT GASKET
BODY-BONNET
CONNECTION

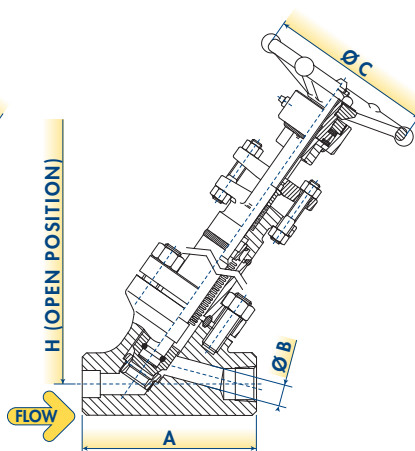

DESIGN TYPE P6
GEAR OPERATED
& RING JOINT GASKET
BODY-BONNET
CONNECTION

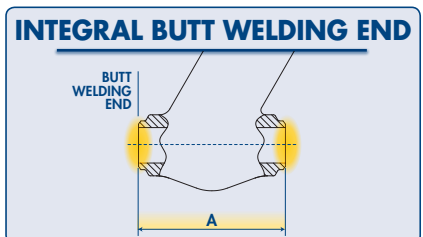
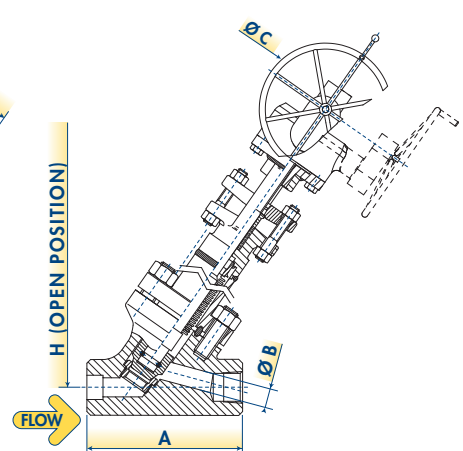

OTHER END CONNECTION TYPES AVAILABLE

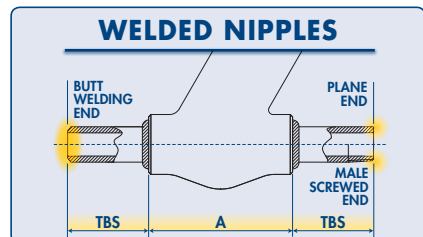

"Y"-PATTERN GLOBE VALVES

BOLTED BONNET GLOBE VALVES BELLOW SEAL CONFIGURATION ASME INTEGRAL FLANGED ENDS



WORKING PRESSURE RATING	SIZE		STANDARD DESIGN TYPE	A-RF		A-RJ		B		C		H		WEIGHT		FIGURE
	NPS	DN		mm	in	mm	in	mm	in	mm	in	mm	in	kg	lb	
ASME 150 (SEE NOTE 1)	1/2"	15	P4	152.5 ⁽¹⁾	6.00	N.A.	N.A.	13	0.51	88	3.5	259	10.2	5.0	11.0	1SYH 303
	3/4"	20	P4	178 ⁽¹⁾	7.01	N.A.	N.A.	17.5	0.69	97	3.8	304	12.0	8.4	18.5	1SYH 304
	1"	25	P4	203 ⁽¹⁾	7.99	216 ⁽¹⁾	8.49	22.5	0.89	138	5.4	354	13.9	11.4	25.2	1SYH 305
	1-1/2"	40	P4	229 ⁽¹⁾	9.02	241 ⁽¹⁾	9.52	35	1.38	138	5.4	416	16.4	21.7	47.7	1SYH 307
	2"	50	P4	267 ⁽¹⁾	10.51	282.5 ⁽¹⁾	11.13	45	1.77	172	6.8	442	17.4	32.8	72.3	1SYH 308
ASME 300	1/2"	15	P4	152.5	6.00	163.5	6.44	13	0.51	88	3.5	259	10.2	5.4	11.9	3SYH 303
	3/4"	20	P4	178	7.01	190.5	7.51	17.5	0.69	97	3.8	304	12.0	9.2	20.3	3SYH 304
	1"	25	P4	203	7.99	216	8.49	22.5	0.89	138	5.4	354	13.9	12.7	28.1	3SYH 305
	1-1/2"	40	P4	229	9.02	241	9.52	35	1.38	138	5.4	416	16.4	24.3	53.5	3SYH 307
	2"	50	P4	267	10.51	282.5	11.13	45	1.77	172	6.8	442	17.4	36.8	81.0	3SYH 308
ASME 600	1/2"	15	P4	165	6.50	163.5	6.44	13	0.51	88	3.5	259	10.2	7.7	17.1	6SYH 303
	3/4"	20	P4	191	7.52	190.5	7.52	17.5	0.69	97	3.8	304	12.0	10.5	23.1	6SYH 304
	1"	25	P4	216	8.50	216	8.50	22.5	0.89	138	5.4	354	13.9	13.8	30.4	6SYH 305
	1-1/2"	40	P4	241	9.49	241	9.49	35	1.38	138	5.4	416	16.4	25.6	56.4	6SYH 307
	2"	50	P4	292	11.50	295	11.62	45	1.77	172	6.8	488	19.2	37.4	82.5	6SYH 308
ASME 1500	1/2"	15	P4	216	8.50	216	8.50	12	0.47	138	5.4	317	12.5	11.2	24.6	15SYHF 303
	3/4"	20	P4	229	9.02	229	9.02	14.5	0.57	138	5.4	370	14.6	16.9	37.3	15SYHF 304
	1"	25	P4	254	10.00	254	10.00	19	0.75	138	5.4	389	15.3	22.3	49.2	15SYHF 305
	1-1/2"	40	P4	305	12.01	305	12.01	31	1.22	172	6.8	488	19.2	39.4	86.8	15SYHF 307
	2"	50	P4	368	14.49	371.5	14.61	38	1.50	234	9.2	614	24.2	76.1	167.8	15SYHF 308
ASME 2500	1/2"	15	P5	264	10.39	264	10.39	11	0.43	138	5.4	409	16.1	21.7	47.7	25SYRF 303
	3/4"	20	P5	273	10.75	273	10.75	14.5	0.57	138	5.4	416	16.4	24.3	53.5	25SYRF 304
	1"	25	P5	308	12.13	308	12.13	19	0.75	172	6.8	462	18.2	39.4	86.8	25SYRF 305
	1-1/2"	40	P5	384	15.12	387	15.24	28	1.10	234	9.2	594	23.4	80.7	178.0	25SYRF 307
	2"	50	P6	451	17.76	454	17.88	38	1.50	400	15.7	607	23.9	87.9	193.9	25SYRF 308

FULL BORE

BPF reserves the right to change designs, dimensions or specifications without notice.

PRODUCT FEATURES:

- Outside Screw and Yoke (OS&Y).
 - Self aligning two piece packing gland.
 - Integral backseat.
 - Integral body flanges.
- NOTE 1: Face-to-Face acc. to ASME B16.10 related to class 300.

DESIGN TYPE P4

**HANDWHEEL OPERATED
& SPIRAL WOUND
GASKET BODY-BONNET
CONNECTION**

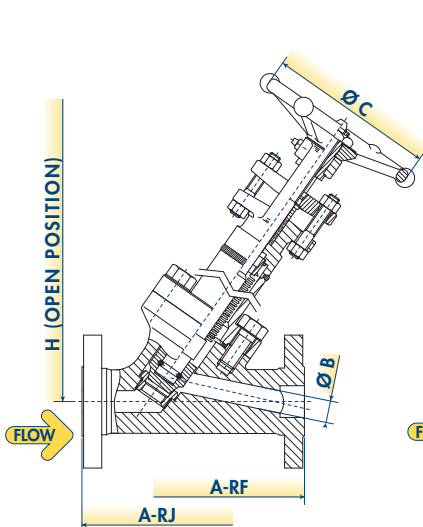

DESIGN TYPE P5

**HANDWHEEL OPERATED
WITH THRUST BEARINGS &
RING JOINT GASKET
BODY-BONNET CONNECTION**

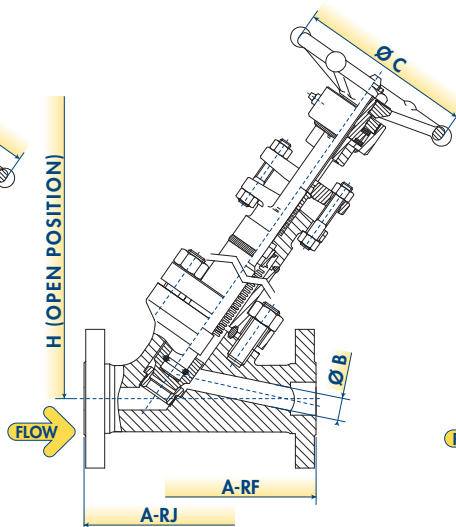

DESIGN TYPE P6

**GEAR OPERATED & RING
JOINT GASKET
BODY-BONNET
CONNECTION**

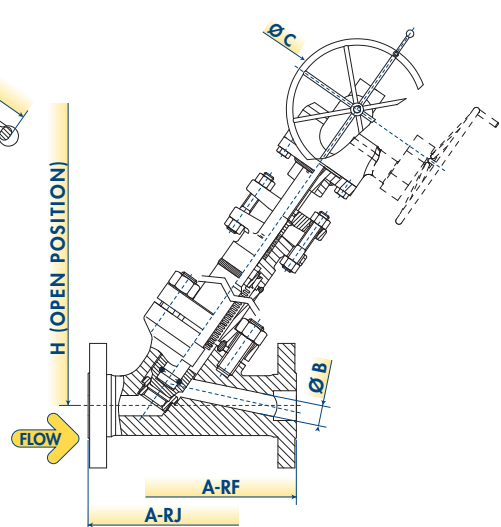

"Y"-PATTERN GLOBE VALVES

WELDED BONNET GLOBE VALVES BASIC CONFIGURATION THREADED AND SOCKET WELD ENDS



WORKING PRESSURE RATING	SIZE		STANDARD DESIGN TYPE	A		B		C		H		WEIGHT		FIGURE
	NPS	DN		mm	in	mm	in	mm	in	mm	in	kg	lb	
ASME 800	1/4"	6	W1	85	3.35	7	0.28	88	3.5	174	6.9	2	4.4	Y 301
	3/8"	10	W1	85	3.35	9	0.35	88	3.5	174	6.9	2	4.4	Y 302
	1/2"	15	W1	85	3.35	13	0.51	88	3.5	174	6.9	2	4.4	Y 303
	3/4"	20	W1	105	4.13	17	0.67	97	3.8	215	8.5	3.3	7.3	Y 304
	1"	25	W1	120	4.72	22	0.87	138	5.4	255	10.0	5	11.0	Y 305
	1-1/4"	32	W1	165	6.50	29	1.14	172	6.8	255	10.0	11	24.3	Y 306
	1-1/2"	40	W1	165	6.50	35	1.38	172	6.8	318	12.5	11	24.3	Y 307
2"	50	W1	190	7.48	45	1.77	172	6.8	375	14.8	15	33.1	Y 308	
ASME 1500	1/4"	6	W1	85	3.35	7	0.28	88	3.5	175	6.9	2	4.4	9Y 301
	3/8"	10	W1	85	3.35	9	0.35	88	3.5	175	6.9	2	4.4	9Y 302
	1/2"	15	W1	85	3.35	10	0.39	97	3.8	215	8.5	3.5	7.7	9Y 303
	3/4"	20	W1	105	4.13	15	0.59	138	5.4	255	10.0	5.3	11.7	9Y 304
	1"	25	W1	120	4.72	22	0.87	138	5.4	280	11.0	11	24.3	9Y 305
	1-1/4"	32	W1	165	6.50	27	1.06	172	6.8	315	12.4	11	24.3	9Y 306
	1-1/2"	40	W1	165	6.50	32	1.26	172	6.8	380	15.0	16.5	36.4	9Y 307
2"	50	W1	190	7.48	43	1.69	234	9.2	450	17.7	26	57.3	9Y 308	
ASME 2500	1/4"	6	W2	85	3.35	7	0.28	88	3.5	220	8.7	3.5	7.7	25Y 301
	3/8"	10	W2	85	3.35	9	0.35	88	3.5	220	8.7	3.5	7.7	25Y 302
	1/2"	15	W2	105	4.13	11	0.43	138	5.4	240	9.4	5	11.0	25Y 303
	3/4"	20	W2	120	4.72	14.5	0.57	138	5.4	275	10.8	11.5	25.4	25Y 304
	1"	25	W2	165	6.50	19	0.75	138	5.4	310	12.2	12.5	27.6	25Y 305
	1-1/4"	32	W2	165	6.50	26	1.02	172	6.8	310	12.2	12.5	27.6	25Y 306
	1-1/2"	40	W2	190	7.48	29	1.14	172	6.8	360	14.2	17	37.5	25Y 307
2"	50	W2	220	8.66	38	1.50	234	9.2	440	17.3	26	57.3	25Y 308	
ASME 4500	1/4"	6	W2	120	4.72	7	0.28	138	5.4	240	9.4	5.5	12.1	45Y 301
	3/8"	10	W2	120	4.72	7	0.28	138	5.4	240	9.4	5.5	12.1	45Y 302
	1/2"	15	W2	120	4.72	8	0.31	138	5.4	245	9.6	5.6	12.3	45Y 303
	3/4"	20	W2	165	6.50	11	0.43	172	6.8	305	12.0	14	30.9	45Y 304
	1"	25	W2	165	6.50	14	0.55	172	6.8	310	12.2	14	30.9	45Y 305
	1-1/2"	40	W2	220	8.66	25	0.98	234	9.2	420	16.5	28	61.7	45Y 307
	2"	50	W4	224	8.82	32	1.26	400	15.7	450	17.7	32	70.5	45Y 308

FULL BORE

BFE reserves the right to change designs, dimensions or specifications without notice.

PRODUCT FEATURES:

- Outside Screw and Yoke (OS&Y).
- Self aligning two piece packing gland.
- Integral backseat.
- Body-Bonnet weld to ASME IX.

DESIGN TYPE W1

HANDWHEEL OPERATED AND V-GROOVE SEAL WELD BODY-BONNET CONNECTION

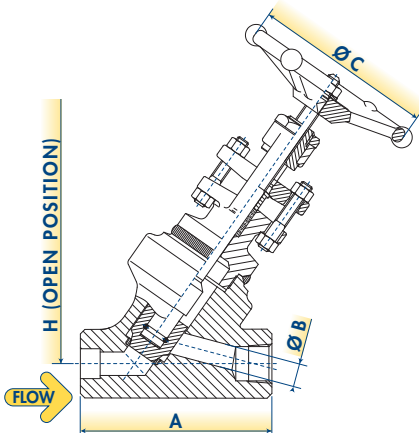

DESIGN TYPE W2

HANDWHEEL OPERATED AND TEE JOINT FILLED WELD BODY-BONNET CONNECTION

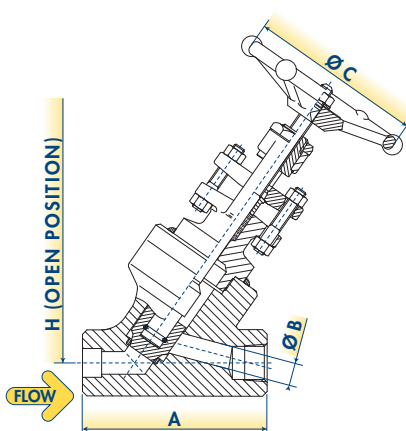

DESIGN TYPE W4

GEAR OPERATED AND TEE JOINT FILLED WELD BODY-BONNET CONNECTION

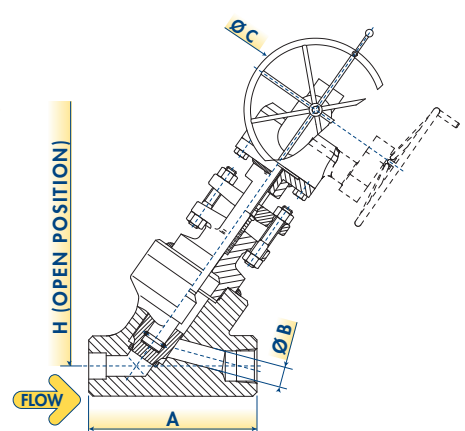

INTEGRAL BUTT WELDING END

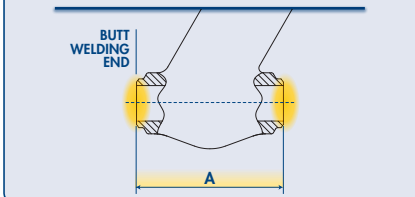

OTHER END CONNECTION TYPES AVAILABLE

WELDED NIPPLES

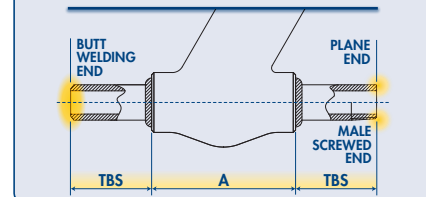

"Y"-PATTERN GLOBE VALVES

WELDED BONNET GLOBE VALVES BASIC CONFIGURATION ASME INTEGRAL FLANGED ENDS



WORKING PRESSURE RATING	SIZE		STANDARD DESIGN TYPE	A-RF		A-RJ		B		C		H		WEIGHT		FIGURE
	NPS	DN		mm	in	mm	in	mm	in	mm	in	mm	in	kg	lb	
ASME 150 (SEE NOTE 1)	1/2"	15	W3	152.5 ⁽¹⁾	6.00	N.A.	N.A.	13	0.51	88	3.5	216	8.5	3.3	7.3	1YHW 303
	3/4"	20	W3	178 ⁽¹⁾	7.01	N.A.	N.A.	17.5	0.69	97	3.8	253	10.0	5.6	12.3	1YHW 304
	1"	25	W3	203 ⁽¹⁾	7.99	216 ⁽¹⁾	8.49	22.5	0.89	138	5.4	295	11.6	7.6	16.8	1YHW 305
	1-1/2"	40	W3	229 ⁽¹⁾	9.02	241 ⁽¹⁾	9.52	35	1.38	172	6.8	347	13.6	14.4	31.8	1YHW 307
	2"	50	W3	267 ⁽¹⁾	10.51	282.5 ⁽¹⁾	11.13	45	1.77	172	6.8	369	14.5	21.9	48.2	1YHW 308
ASME 300	1/2"	15	W3	152.5	6.00	163.5	6.44	13	0.51	88	3.5	216	8.5	3.6	7.9	3YHW 303
	3/4"	20	W3	178	7.01	190.5	7.51	17.5	0.69	97	3.8	253	10.0	6.1	13.5	3YHW 304
	1"	25	W3	203	7.99	216	8.49	22.5	0.89	138	5.4	295	11.6	8.5	18.7	3YHW 305
	1-1/2"	40	W3	229	9.02	241	9.52	35	1.38	172	6.8	347	13.6	16.2	35.7	3YHW 307
	2"	50	W3	267	10.51	282.5	11.13	45	1.77	172	6.8	369	14.5	24.5	54.0	3YHW 308
ASME 600	1/2"	15	W3	165	6.50	163.5	6.44	13	0.51	88	3.5	216	8.5	5.2	11.4	6YHW 303
	3/4"	20	W3	191	7.52	190.5	7.52	17.5	0.69	97	3.8	253	10.0	7.0	15.4	6YHW 304
	1"	25	W3	216	8.50	216	8.50	22.5	0.89	138	5.4	295	11.6	9.2	20.3	6YHW 305
	1-1/2"	40	W3	241	9.49	241	9.49	35	1.38	172	6.8	347	13.6	17.1	37.6	6YHW 307
	2"	50	W3	292	11.50	295	11.62	45	1.77	172	6.8	407	16.0	24.9	55.0	6YHW 308
ASME 1500	1/2"	15	W3	216	8.50	216	8.50	12	0.47	97	3.8	264	10.4	7.4	16.4	15YHWF 303
	3/4"	20	W3	229	9.02	229	9.02	14.5	0.57	138	5.4	308	12.1	11.3	24.9	15YHWF 304
	1"	25	W3	254	10.00	254	10.00	19	0.75	172	6.8	325	12.8	14.9	32.8	15YHWF 305
	1-1/2"	40	W3	305	12.01	305	12.01	31	1.22	172	6.8	407	16.0	26.3	57.9	15YHWF 307
	2"	50	W3	368	14.49	371.5	14.61	38	1.50	234	9.2	512	20.1	50.8	111.9	15YHWF 308
ASME 2500	1/2"	15	W3	264	10.39	264	10.39	11	0.43	138	5.4	341	13.4	14.4	31.8	25YHWF 303
	3/4"	20	W3	273	10.75	273	10.75	14.5	0.57	138	5.4	347	13.6	16.2	35.7	25YHWF 304
	1"	25	W3	308	12.13	308	12.13	19	0.75	172	6.8	385	15.2	26.3	57.9	25YHWF 305
	1-1/2"	40	W3	384	15.12	387	15.24	28	1.10	234	9.2	495	19.5	53.8	118.6	25YHWF 307
	2"	50	W3	451	17.76	454	17.88	38	1.50	320	12.6	506	19.9	58.6	129.2	25YHWF 308

FULL BORE

BFE reserves the right to change designs, dimensions or specifications without notice.

PRODUCT FEATURES:

- Outside Screw and Yoke (OS&Y).
 - Self aligning two piece packing gland.
 - Integral backseat.
 - Integral body flanges
 - Body-Bonnet weld to ASME IX.
- NOTE 1: Face-to-Face acc.to ASME B16.10 related to class 300.

DESIGN TYPE W3

FULL PENETRATION WELD BODY-BONNET CONNECTION

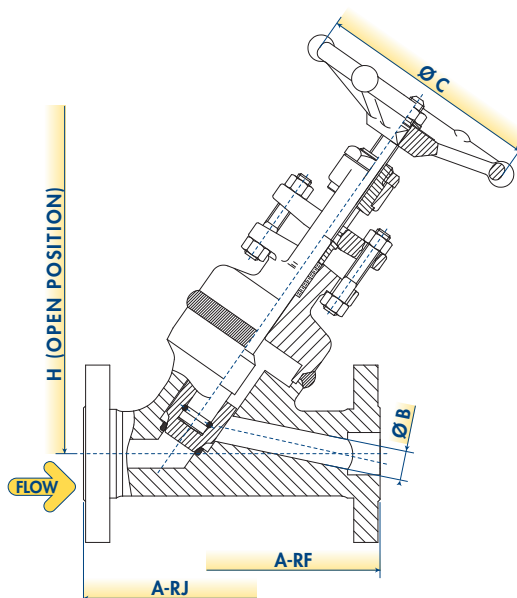

"Y"-PATTERN GLOBE VALVES

WELDED BONNET GLOBE VALVES CRYOGENIC CONFIGURATION THREADED AND SOCKET WELD ENDS



WORKING PRESSURE RATING	SIZE		STANDARD DESIGN TYPE	A		B		C		H		WEIGHT		FIGURE
	NPS	DN		mm	in	mm	in	mm	in	mm	in	kg	lb	
ASME 800	1/4"	6	W1	85	3.35	7	0.28	88	3.5	471	18.5	3.4	7.4	CY 301
	3/8"	10	W1	85	3.35	9	0.35	88	3.5	471	18.5	3.4	7.4	CY 302
	1/2"	15	W1	85	3.35	13	0.51	88	3.5	471	18.5	3.4	7.4	CY 303
	3/4"	20	W1	105	4.13	17	0.67	97	3.8	516	20.3	5.5	12.2	CY 304
	1"	25	W1	120	4.72	22	0.87	138	5.4	560	22.0	8.4	18.5	CY 305
	1-1/4"	32	W1	165	6.50	29	1.14	172	6.8	560	22.0	18.5	40.7	CY 306
	1-1/2"	40	W1	165	6.50	35	1.38	172	6.8	629	24.8	18.5	40.7	CY 307
	2"	50	W1	190	7.48	45	1.77	172	6.8	692	27.2	25.2	55.6	CY 308
ASME 1500	1/4"	6	W1	85	3.35	7	0.28	88	3.5	472	18.6	3.4	7.4	9CY 301
	3/8"	10	W1	85	3.35	9	0.35	88	3.5	472	18.6	3.4	7.4	9CY 302
	1/2"	15	W1	85	3.35	10	0.39	97	3.8	516	20.3	5.9	13.0	9CY 303
	3/4"	20	W1	105	4.13	15	0.59	138	5.4	560	22.0	8.9	19.6	9CY 304
	1"	25	W1	120	4.72	22	0.87	138	5.4	587	23.1	18.5	40.7	9CY 305
	1-1/4"	32	W1	165	6.50	27	1.06	172	6.8	626	24.6	18.5	40.7	9CY 306
	1-1/2"	40	W1	165	6.50	32	1.26	172	6.8	697	27.5	27.7	61.1	9CY 307
	2"	50	W1	190	7.48	43	1.69	234	9.2	774	30.5	43.7	96.3	9CY 308
ASME 2500	1/4"	6	W2	85	3.35	7	0.28	88	3.5	521	20.5	5.9	13.0	25CY 301
	3/8"	10	W2	85	3.35	9	0.35	88	3.5	521	20.5	5.9	13.0	25CY 302
	1/2"	15	W2	105	4.13	11	0.43	138	5.4	543	21.4	8.4	18.5	25CY 303
	3/4"	20	W2	120	4.72	14.5	0.57	138	5.4	582	22.9	19.3	42.6	25CY 304
	1"	25	W2	165	6.50	19	0.75	138	5.4	620	24.4	21.0	46.3	25CY 305
	1-1/4"	32	W2	165	6.50	26	1.02	172	6.8	620	24.4	21.0	46.3	25CY 306
	1-1/2"	40	W2	190	7.48	29	1.14	172	6.8	675	26.6	28.6	63.0	25CY 307
	2"	50	W2	220	8.66	38	1.50	234	9.2	763	30.1	43.7	96.3	25CY 308
ASME 4500	1/4"	6	W2	120	4.72	7	0.28	138	5.4	543	21.4	9.2	20.4	45CY 301
	3/8"	10	W2	120	4.72	7	0.28	138	5.4	543	21.4	9.2	20.4	45CY 302
	1/2"	15	W2	120	4.72	8	0.31	138	5.4	549	21.6	9.4	20.7	45CY 303
	3/4"	20	W2	165	6.50	11	0.43	172	6.8	615	24.2	23.5	51.9	45CY 304
	1"	25	W2	165	6.50	14	0.55	172	6.8	620	24.4	23.5	51.9	45CY 305
	1-1/2"	40	W2	220	8.66	25	0.98	234	9.2	741	29.2	47.0	103.7	45CY 307
	2"	50	W4	224	8.82	32	1.26	400	15.7	774	30.5	53.8	118.5	45CY 308

FULL BORE

BPE reserves the right to change designs, dimensions or specifications without notice.

PRODUCT FEATURES:

- Outside Screw and Yoke (OS&Y).
- Self aligning two piece packing gland.
- Integral backseat.
- Body-Bonnet weld to ASME IX.

**DESIGN TYPE W1
V-GROOVE SEAL
WELD BODY-BONNET
CONNECTION**

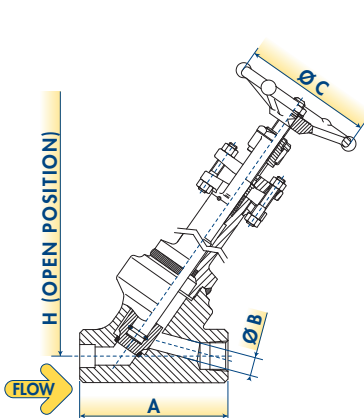

**DESIGN TYPE W2
TEE JOINT FILLET
WELD BODY-BONNET
CONNECTION**

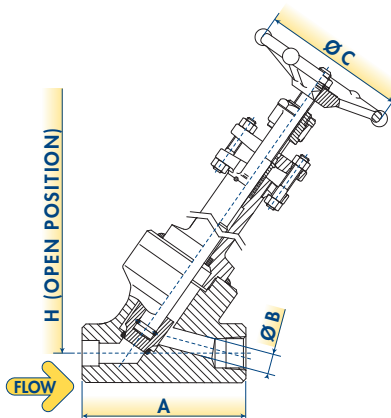

**DESIGN TYPE W4
GEAR OPERATED & TEE
JOINT FILLET WELD
BODY-BONNET CONNECTION**

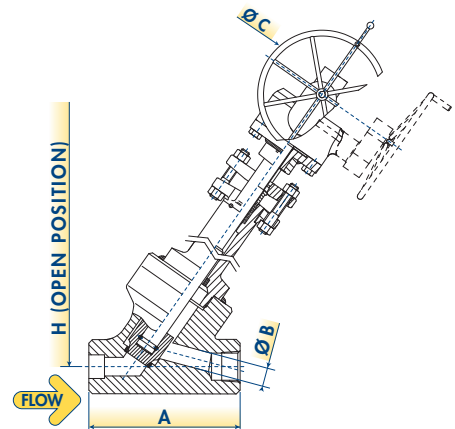

INTEGRAL BUTT WELDING END

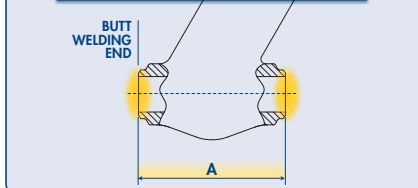

OTHER END CONNECTION TYPES AVAILABLE

WELDED NIPPLES

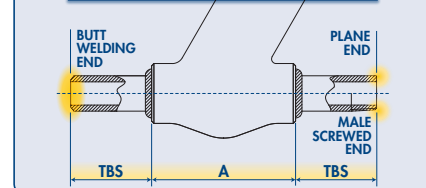

"Y"-PATTERN GLOBE VALVES

WELDED BONNET GLOBE VALVES CRYOGENIC CONFIGURATION ASME INTEGRAL FLANGED ENDS



WORKING PRESSURE RATING	SIZE		STANDARD DESIGN TYPE	A-RF		A-RJ		B		C		H		WEIGHT		FIGURE
	NPS	DN		mm	in	mm	in	mm	in	mm	in	mm	in	kg	lb	
ASME 150 (SEE NOTE 1)	1/2"	15	W3	152.5 ⁽¹⁾	6.00	N.A.	N.A.	13	0.51	88	3.5	495	19.5	5.0	11.0	1CYHW 303
	3/4"	20	W3	178 ⁽¹⁾	7.01	N.A.	N.A.	17.5	0.69	97	3.8	532	21.0	8.4	18.5	1CYHW 304
	1"	25	W3	203 ⁽¹⁾	7.99	216 ⁽¹⁾	5.50	22.5	0.89	138	5.4	574	22.6	11.4	25.2	1CYHW 305
	1-1/2"	40	W3	229 ⁽¹⁾	9.02	241 ⁽¹⁾	7.00	35	1.38	172	6.8	626	24.6	21.7	47.7	1CYHW 307
	2"	50	W3	267 ⁽¹⁾	10.51	282.5 ⁽¹⁾	8.49	45	1.77	172	6.8	648	25.5	32.8	72.3	1CYHW 308
ASME 300	1/2"	15	W3	152.5	6.00	163.5	6.44	13	0.51	88	3.5	495	19.5	5.4	11.9	3CYHW 303
	3/4"	20	W3	178	7.01	190.5	7.51	17.5	0.69	97	3.8	532	21.0	9.2	20.3	3CYHW 304
	1"	25	W3	203	7.99	216	8.49	22.5	0.89	138	5.4	574	22.6	12.7	28.1	3CYHW 305
	1-1/2"	40	W3	229	9.02	241	9.52	35	1.38	172	6.8	626	24.6	24.3	53.5	3CYHW 307
	2"	50	W3	267	10.51	282.5	11.13	45	1.77	172	6.8	648	25.5	36.8	81.0	3CYHW 308
ASME 600	1/2"	15	W3	165	6.50	163.5	6.44	13	0.51	88	3.5	495	19.5	7.7	17.1	6CYHW 303
	3/4"	20	W3	191	7.52	190.5	7.52	17.5	0.69	97	3.8	532	21.0	10.5	23.1	6CYHW 304
	1"	25	W3	216	8.50	216	8.50	22.5	0.89	138	5.4	574	22.6	13.8	30.4	6CYHW 305
	1-1/2"	40	W3	241	9.49	241	9.49	35	1.38	172	6.8	626	24.6	25.6	56.4	6CYHW 307
	2"	50	W3	292	11.50	295	11.62	45	1.77	172	6.8	686	27.0	37.4	82.5	6CYHW 308
ASME 1500	1/2"	15	W3	216	8.50	216	8.50	12	0.47	97	3.8	543	21.4	11.2	24.6	15CYHWF 303
	3/4"	20	W3	229	9.02	229	9.02	14.5	0.57	138	5.4	587	23.1	16.9	37.3	15CYHWF 304
	1"	25	W3	254	10.00	254	10.00	19	0.75	172	6.8	604	23.8	22.3	49.2	15CYHWF 305
	1-1/2"	40	W3	305	12.01	305	12.01	31	1.22	172	6.8	686	27.0	39.4	86.8	15CYHWF 307
	2"	50	W3	368	14.49	371.5	14.61	38	1.50	234	9.2	791	31.1	76.1	167.8	15CYHWF 308
ASME 2500	1/2"	15	W3	264	10.39	264	10.39	11	0.43	138	5.4	620	24.4	21.7	47.7	25CYHWF 303
	3/4"	20	W3	273	10.75	273	10.75	14.5	0.57	138	5.4	626	24.6	24.3	53.5	25CYHWF 304
	1"	25	W3	308	12.13	308	12.13	19	0.75	172	6.8	664	26.2	39.4	86.8	25CYHWF 305
	1-1/2"	40	W3	384	15.12	387	15.24	28	1.10	234	9.2	774	30.5	80.7	178.0	25CYHWF 307
	2"	50	W3	451	17.76	454	17.88	38	1.50	320	12.6	785	30.9	87.9	193.9	25CYHWF 308

FULL BORE

BFE reserves the right to change designs, dimensions or specifications without notice.

PRODUCT FEATURES:

- Outside Screw and Yoke (OS&Y).
- Self aligning two piece packing gland.
- Integral backseat.
- Integral body flanges.
- Body-Bonnet weld to ASME IX.

NOTE 1: Face-to-Face acc.to ASME B16.10 related to class 300.

DESIGN TYPE W3

FULL PENETRATION WELD BODY-BONNET CONNECTION

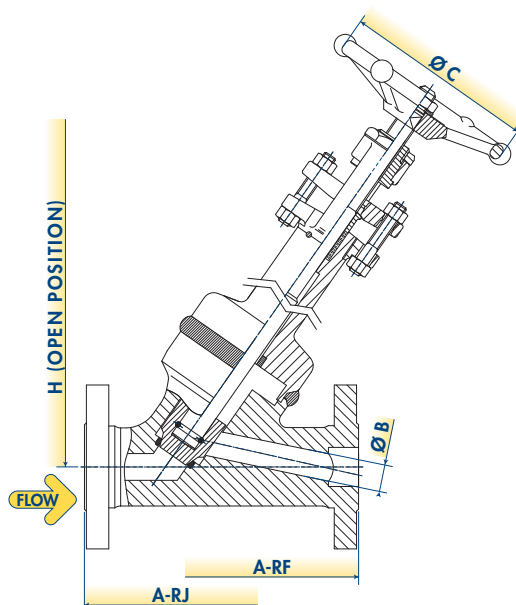

"Y"-PATTERN GLOBE VALVES

WELDED BONNET GLOBE VALVES BELLOW SEAL CONFIGURATION THREADED AND SOCKET WELD ENDS



WORKING PRESSURE RATING	SIZE		STANDARD DESIGN TYPE	A		B		C		H		WEIGHT		FIGURE
	NPS	DN		mm	in	mm	in	mm	in	mm	in	kg	lb	
ASME 800	1/4"	6	P1	85	3.35	7	0.28	88	3.5	209	8.2	2.4	5.3	SYHW 301
	3/8"	10	P1	85	3.35	9	0.35	88	3.5	209	8.2	2.4	5.3	SYHW 302
	1/2"	15	P1	85	3.35	13	0.51	88	3.5	215	8.4	3.4	7.4	SYHW 303
	3/4"	20	P1	105	4.13	17	0.67	97	3.8	248	9.7	5.3	11.6	SYHW 304
	1"	25	P1	120	4.72	22	0.87	138	5.4	298	11.7	8.4	18.5	SYHW 305
	1-1/4"	32	P1	165	6.50	29	1.14	138	5.4	347	13.6	9.5	20.8	SYHW 306
	1-1/2"	40	P1	165	6.50	35	1.38	172	6.8	392	15.4	17.9	39.4	SYHW 307
2"	50	P1	190	7.48	45	1.77	172	6.8	472	18.6	29.4	64.8	SYHW 308	
ASME 1500	1/4"	6	P1	85	3.35	7	0.28	97	3.8	209	8.2	3.4	7.4	9SYHW 301
	3/8"	10	P1	85	3.35	9	0.35	97	3.8	209	8.2	3.4	7.4	9SYHW 302
	1/2"	15	P1	85	3.35	10	0.39	138	5.4	267	10.5	4.2	9.3	9SYHW 303
	3/4"	20	P1	105	4.13	15	0.59	172	6.8	315	12.4	6.8	15.0	9SYHW 304
	1"	25	P1	120	4.72	22	0.87	234	9.2	342	13.5	8.7	19.2	9SYHW 305
	1-1/4"	32	P1	165	6.50	27	1.06	234	9.2	385	15.2	12.6	27.8	9SYHW 306
	1-1/2"	40	P1	165	6.50	32	1.26	320	12.6	490	19.3	23.1	50.9	9SYHW 307
2"	50	P1	190	7.48	43	1.69	320	12.6	561	22.1	38.3	84.5	9SYHW 308	
ASME 2500	1/4"	6	P2	85	3.35	7	0.28	97	3.8	297	11.7	5.3	11.6	25SYHW 301
	3/8"	10	P2	85	3.35	9	0.35	138	5.4	330	13.0	6.8	15.0	25SYHW 302
	1/2"	15	P2	105	4.13	11	0.43	172	6.8	385	15.2	7.4	16.2	25SYHW 303
	3/4"	20	P2	120	4.72	14.5	0.57	234	9.2	440	17.3	11.0	24.3	25SYHW 304
	1"	25	P2	165	6.50	19	0.75	320	12.6	517	20.4	17.9	39.4	25SYHW 305
	1-1/4"	32	P2	165	6.50	26	1.02	320	12.6	550	21.7	21.0	46.3	25SYHW 306
	1-1/2"	40	P2	190	7.48	29	1.14	320	12.6	583	23.0	24.2	53.2	25SYHW 307
2"	50	P3	220	8.66	38	1.50	400	15.7	715	28.1	47.3	104.2	25SYHW 308	

FULL BORE

BFE reserves the right to change designs, dimensions or specifications without notice.

PRODUCT FEATURES:

- Outside Screw and Yoke (OS&Y).
- Self aligning two piece packing gland.
- Integral backseat.
- Body-Bonnet weld to ASME IX.

DESIGN TYPE P1 HANDWHEEL OPERATED

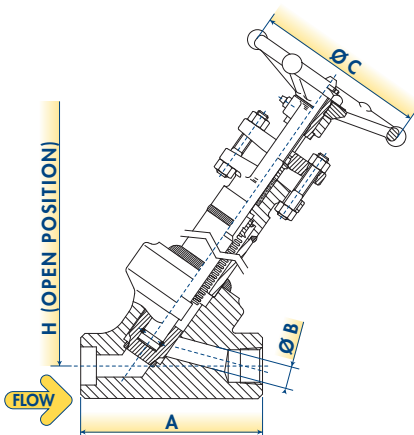

DESIGN TYPE P2 HANDWHEEL OPERATED WITH THRUST BEARINGS

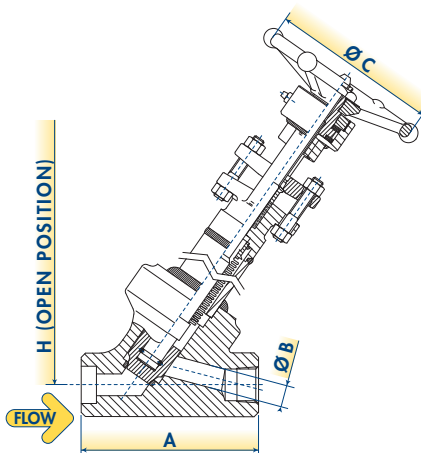

DESIGN TYPE P3 GEAR OPERATED

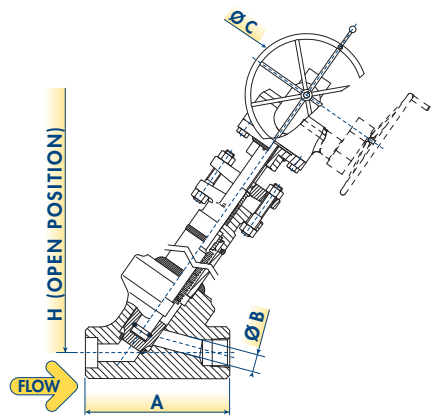

INTEGRAL BUTT WELDING END

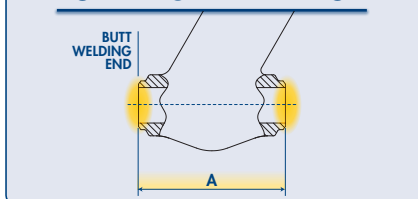

OTHER END CONNECTION TYPES AVAILABLE

WELDED NIPPLES

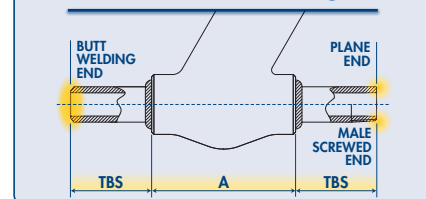

"Y"-PATTERN GLOBE VALVES

WELDED BONNET GLOBE VALVES BELLOW SEAL CONFIGURATION ASME INTEGRAL FLANGED ENDS



WORKING PRESSURE RATING	SIZE		STANDARD DESIGN TYPE	A-RF		A-RJ		B		C		H		WEIGHT		FIGURE
	NPS	DN		mm	in	mm	in	mm	in	mm	in	mm	in	kg	lb	
ASME 150 (SEE NOTE 1)	1/2"	15	P1	152.5 ⁽¹⁾	6.00	N.A.	N.A.	13	0.51	88	3.5	241	9.5	4.1	8.9	1SYHW 303
	3/4"	20	P1	178 ⁽¹⁾	7.01	N.A.	N.A.	17.5	0.69	97	3.8	283	11.2	6.8	15.1	1SYHW 304
	1"	25	P1	203 ⁽¹⁾	7.99	216 ⁽¹⁾	5.50	22.5	0.89	138	5.4	330	13.0	9.3	20.5	1SYHW 305
	1-1/2"	40	P1	229 ⁽¹⁾	9.02	241 ⁽¹⁾	7.00	35	1.38	172	6.8	388	15.3	17.6	38.8	1SYHW 307
	2"	50	P1	267 ⁽¹⁾	10.51	282.5 ⁽¹⁾	8.49	45	1.77	172	6.8	413	16.2	26.7	58.8	1SYHW 308
ASME 300	1/2"	15	P1	152.5	6.00	163.5	6.44	13	0.51	88	3.5	241	9.5	4.4	9.6	3SYHW 303
	3/4"	20	P1	178	7.01	190.5	7.51	17.5	0.69	97	3.8	283	11.2	7.5	16.5	3SYHW 304
	1"	25	P1	203	7.99	216	8.49	22.5	0.89	138	5.4	330	13.0	10.4	22.8	3SYHW 305
	1-1/2"	40	P1	229	9.02	241	9.52	35	1.38	172	6.8	388	15.3	19.7	43.5	3SYHW 307
	2"	50	P1	267	10.51	282.5	11.13	45	1.77	172	6.8	413	16.2	29.9	65.9	3SYHW 308
ASME 600	1/2"	15	P1	165	6.50	163.5	6.44	13	0.51	88	3.5	241	9.5	6.3	13.9	3SYHW 303
	3/4"	20	P1	191	7.52	190.5	7.52	17.5	0.69	97	3.8	283	11.2	8.5	18.8	6SYHW 304
	1"	25	P1	216	8.50	216	8.50	22.5	0.89	138	5.4	330	13.0	11.2	24.7	6SYHW 305
	1-1/2"	40	P1	241	9.49	241	9.49	35	1.38	172	6.8	388	15.3	20.8	45.9	6SYHW 307
	2"	50	P1	292	11.50	295	11.62	45	1.77	172	6.8	456	17.9	30.4	67.1	6SYHW 308
ASME 1500	1/2"	15	P1	216	8.50	216	8.50	12	0.47	97	3.8	296	11.6	9.1	20.0	15SYHWF 303
	3/4"	20	P1	229	9.02	229	9.02	14.5	0.57	138	5.4	345	13.6	13.8	30.4	15SYHWF 304
	1"	25	P1	254	10.00	254	10.00	19	0.75	172	6.8	363	14.3	18.1	40.0	15SYHWF 305
	1-1/2"	40	P1	305	12.01	305	12.01	31	1.22	172	6.8	456	17.9	32.0	70.6	15SYHWF 307
	2"	50	P1	368	14.49	371.5	14.61	38	1.50	234	9.2	573	22.6	61.9	136.5	15SYHWF 308
ASME 2500	1/2"	15	P2	264	10.39	264	10.39	11	0.43	138	5.4	382	15.0	17.6	38.8	25SYHWF 303
	3/4"	20	P2	273	10.75	273	10.75	14.5	0.57	138	5.4	388	15.3	19.7	43.5	25SYHWF 304
	1"	25	P2	308	12.13	308	12.13	19	0.75	172	6.8	431	17.0	32.0	70.6	25SYHWF 305
	1-1/2"	40	P2	384	15.12	387	15.24	28	1.10	234	9.2	554	21.8	65.7	144.7	25SYHWF 307
	2"	50	P3	451	17.76	454	17.88	38	1.50	320	12.6	567	22.3	71.5	157.7	25SYHWF 308

FULL BORE

B/E reserves the right to change designs, dimensions or specifications without notice.

PRODUCT FEATURES:

- Outside Screw and Yoke (OS&Y).
- Self aligning two piece packing gland.
- Integral backseat.
- Integral body flanges.

NOTE 1: Face-to-Face acc.to ASME B16.10 related to class 300.

DESIGN TYPE P1
HANDWHEEL OPERATED

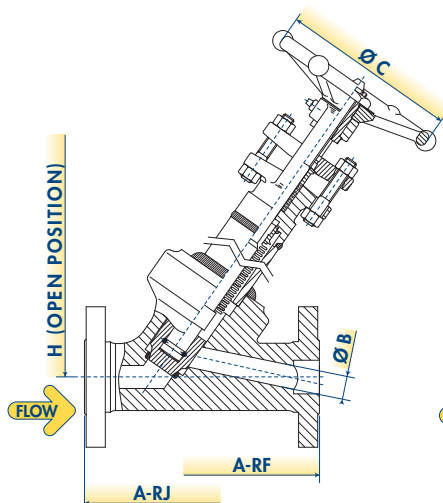

DESIGN TYPE P2

HANDWHEEL OPERATED WITH THRUST BEARINGS

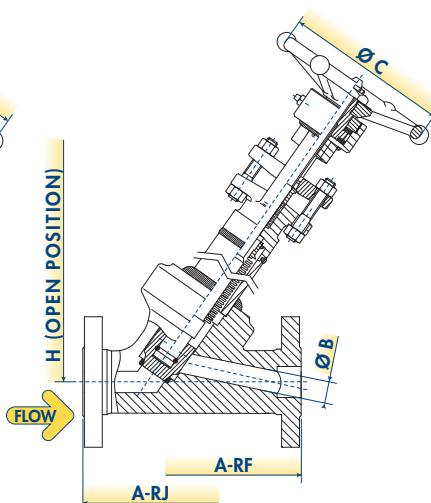

DESIGN TYPE P3

GEAR OPERATED

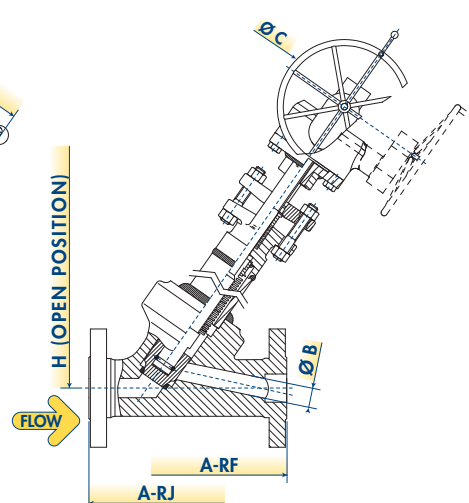

"Y"-PATTERN GLOBE VALVES

AVAILABLE OPTIONS FOR "Y"-PATTERN GLOBE VALVES OTHER VALVE OPTIONS OR CUSTOMISED VERSIONS ARE AVAILABLE ON REQUEST, CONTACT BFE FOR SPECIAL REQUIREMENTS.

STEM EXTENSION

Valve handle can be extended to allow for panel mount and pipe insulation.

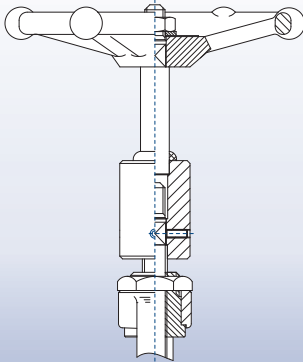

BEVEL GEAR OPERATOR

Gearing can be applied to valves instead of the standard handwheel to make operation easier.

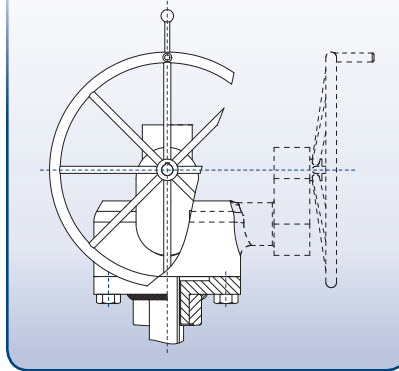

POSITION INDICATOR

Valves can be supplied with standard visual-mechanical indicating device that act as stem cover also.

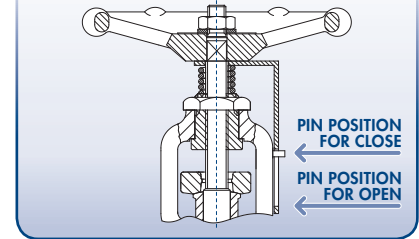

STOP CHECK

Globe valves with stop check option have a guided loose disc allowing the valve to act as a combination globe and check valve. There is the manual control to regulate the opening and closing, and can be completely stopped or shut off. This type of valve will generally be used as a globe valve to start or stop the flow of the media, but will automatically close should pressure be lost in the line, preventing backflow.

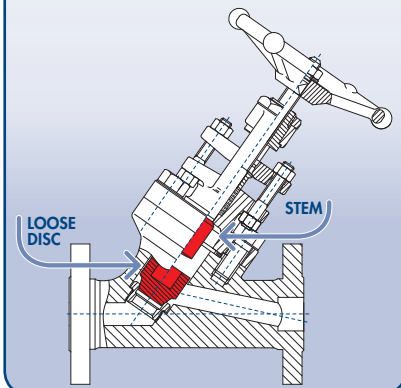

DEAD MAN OPERATOR

Dead Man Handle automatically closes the valve when operator Releases Handle. This means the operator must hold the handle in the open position for the product to flow. The operator can't walk away or the valve will shut off. Locking handle option for our spring return deadman handle is available.

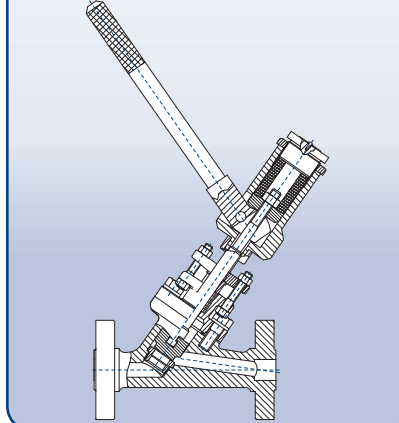

ACTUATOR-READY

Valves can be supplied ready for actuation without the handwheel or gear box. The mounting connection can be BFE Standard or can suit the choice or type of actuator.

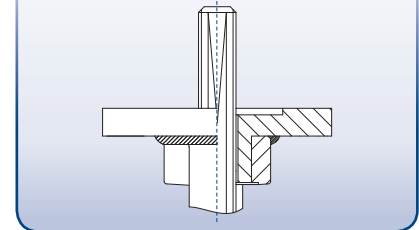

ELECTRIC, PNEUMATIC OR HYDRAULIC ACTUATORS

Motorized controls may be applied to valves of any size for operation in any position or location.

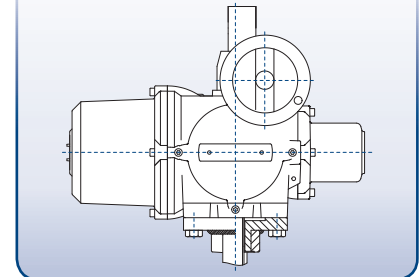

LOCKING DEVICE

Locking devices designed to help prevent accidental or unwanted operation by being built to resist excessive force or unusual abuse. All BFE locking device option are simple but secure. Chain and Padlock available on request.

LOCKING FACILITY

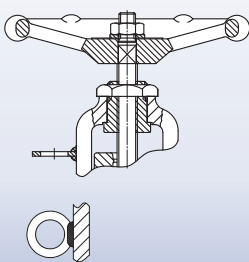

LOCKING FACILITY WITH C&P

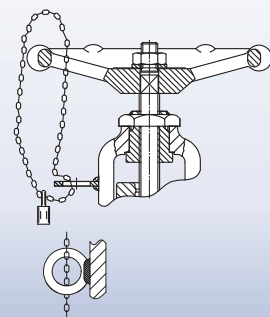

LOCKING DEVICE

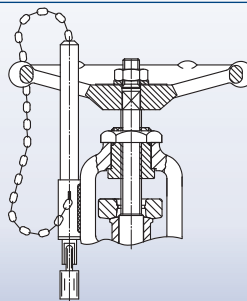

THERMAL EXPANSION STEM COMPENSATOR

Valves which endure large thermal transients have the basic problem that the valve stem and closure member will expand and contract with the danger that a closed valve could become jammed in its seat and in extreme cases this can cause the valve stem to distort. High Temperature Valve configuration is equipped with a spring loaded stem sleeve that will absorb any expansion or contraction caused by temperature fluctuations without affecting the position of the closed valve stem.

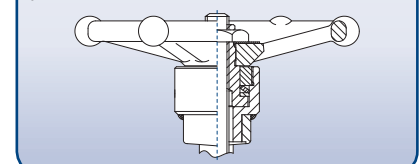

"Y"-PATTERN GLOBE VALVES

AVAILABLE OPTIONS FOR "Y"-PATTERN GLOBE VALVES OTHER VALVE OPTIONS OR CUSTOMISED VERSIONS ARE AVAILABLE ON REQUEST, CONTACT BFE FOR SPECIAL REQUIREMENTS.

DISC AND TRIM TYPE

BFE standard plug is the has a quick opening characteristic, this plug provides maximum flow with minimum pressure drop and is ideal when large flows are required just after opening. All BFE standard plugs require a flow direction FTO type. BFE trim variations can offer maximum versatility in flow control application within the capability of globe valve design.

PARABOLIC DISC TRIM TYPE

Characteristic: Linear. This plug covers all Cv ranges and is especially suitable for low differential pressures.

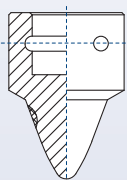

NEEDLE TRIM TYPE

Needle trim design is suitable for use where low valve CV values or low flows are required.

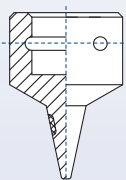

BLOW DOWN TRIM STANDARD TYPE

Blow Down trim design is suitable for use where high differential pressures are present. The high pressure drop causes erosion and cavitation which can destroy conventional globe valves.

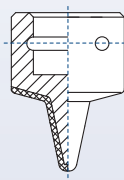

BLOW DOWN TRIM MULTI-STEP TYPE

Improved blow-down trim developed to provide a high number of pressure letdown steps to minimise the potential for excessive noise, cavitation, vibration and erosion. Multi-Step trim has been designed for all fluid combinations, both clean and dirty service. This range of trims is normally customized and designed on the customer design data.

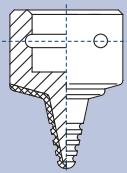

BALL DISC TRIM TYPE

The ball disc is used where the applications involve low pressure and low temperature systems. Though the ball disc can be used for throttling purpose, the efficiency might not be as expected.

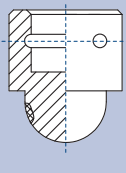

SOFT SEATED PLUG

Soft seated trim provides improved seat tightness at low differential pressures. This design feature includes a plastic sealing member on the valve closure element to supplement the basic metal-to-metal seating function. The design and material selection for these sealing members are based on customer pressure, temperature and compatibility with the line fluid.

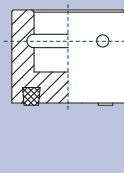

STEM DOUBLE SEAL

Stem double seal are fitted to valves when hazardous fluids are handled or when external lubrication is used. Valves operating under vacuum or with high temperature liquid may have a flowing liquid quench between the seals. The most usual form of double seal is two sets of packing, the lantern ring can provide extra stem guidance. BFE can supply the lantern ring version with standard plug or with injector (double ball check type). Other special configuration are available on request.

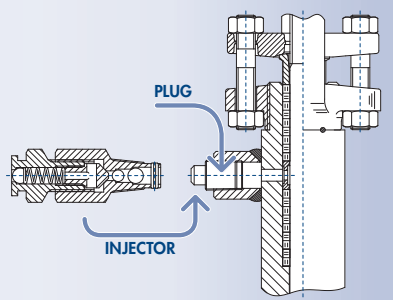

BODY-BONNET FULL PENETRATION WELD

BFE standard welded bonnet valves have as standard a seal weld on the body-bonnet connection. Seal weld is a weld that does not contribute anything to the mechanical integrity of an assembly, but is made purely to seal or prevent leakage from, for instance, a threaded joint. When High-End quality is required for body-bonnet weld joint a weld with full penetration can be performed. Full penetration weld is one in which there is a complete penetration and fusion of weld and parent metal throughout the thickness of the joint. A full penetration weld ensures a fully welded interface between the two parts and is generally the strongest joint.

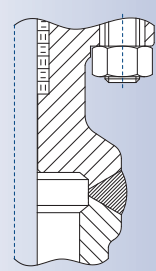

SPECIAL END FINISH

The choice of end connections for connecting a valve to its associated pipe is performed by customers. Common end finish steated in the catalogue are socket, threaded, flanged (RF or RJ) and butt-weld ends. BFE is basically able to perform any end finish as per customer request, special end finish Other end finish as follows: hub, compact flange, any ASME B16.5 end finish other than RF and RJ, etc.

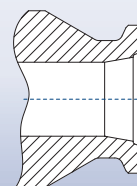

LIMIT SWITCH ASSEMBLIES

Position Limit Switch assemblies enables a remote signaling of the control system the opening of the valve. It can be equipped with one or two switches actuated by closing or opening of the valve. Limit swich can be selected by customer, bracket is designed by BFE.

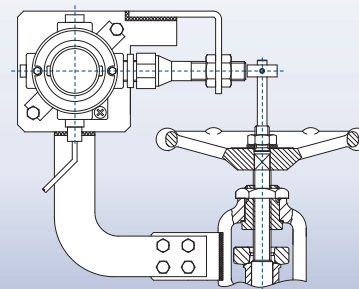

LIVE LOADING

Live Loading System consists of a spring system installed on packing stud to warrant a continuous load on valve packing. Spring are specially designed to allow appropriate load in case of packing settling by minimizing initial load and friction. Mechanical visual indicator of the spring compression is included.

