

# SWING CHECK VALVES

Full die forged structure for all pressure containing parts.

Flanged valves are provided with flanges integral with the body forgings.

Standard construction of body-bonnet connections is bolted bonnet type. Welded bonnet is available as alternative construction.

Standard gasket design for bolted-bonnet valves is spiral wound type up to class ASME 1500. Ring Joint gaskets are standard for ASME 2500 and above. SPW/RJ are available on request for all pressure classes as option.

Center-of-gravity location of the disc and swing arm assembly designed in order to minimize pressure drop and suitable for vertical installation as standard: the valve will return to the closed position should flow become interrupted or reversed even with vertical installation (flow must be in an up-flow direction).

Internal hinge pin design eliminates additional leakage points.

High flow capacity port sizes and disc retraction to minimize flow velocities and maximize valve service life.

Design of disc and hinge assembly to generate a closing moment to provide adequate closure and sealing at low pressures.

## SWING CHECK VALVE DESCRIPTION

Swing check valves, like all check valves, are used to prevent back flow in the line. The pressure of the fluid passing through a system opens the valve, while any reversal of flow will close the valve. The swing check valve functions by allowing flow forces to move the closure element, it is a hinged clapper which swings or rotates around a supporting shaft.

The disk swings away from the valve-seat to allow flow in the forward direction, and returns to the valve-seat when upstream flow is stopped, to prevent backflow.

Swing check design is one of the most common and best check valve for general-purpose use. These valves produce the lowest pressure drop, when compared with other check valves of the same size, the internal contours and shapes allow them to fully open at low fluid velocities and create a smooth flow path through the valve.

The design is simple and easy to maintain and can be used for either horizontal or vertical (fluid flowing upward) pipe layouts. Because of their design, swing checks are not fast-closing valves due to the travel distance from full open to close.

Sealing surfaces are machined to the tightest tolerances and lowest roughness to ensure trouble free shut off and cycling.

Low cracking pressure design.

Best-in-Class CV values.

Swing check nut positively secured to prevent disassembly during service by permanent cold deformation of the closure member. No additional cotter pin or other small parts are used as locking system.









### P&ID SYMBOL



### STANDARD CONFIGURATIONS



# SECTION INDEX OF SWING CHECK VALVES

PAGE	DESCRIPTION	SYM
E-3	BOLTED BONNET SWING CHECK VALVES BASIC CONFIGURATION	
	THREADED AND SOCKET WELD ENDS	
E-4	BOLTED BONNET SWING CHECK VALVES BASIC CONFIGURATION	
	ASME INTEGRAL FLANGED ENDS	
E-5	WELDED BONNET SWING CHECK VALVES BASIC CONFIGURATION	
	THREADED AND SOCKET WELD ENDS	
E-6	WELDED BONNET SWING CHECK VALVES BASIC CONFIGURATION	
	ASME INTEGRAL FLANGED ENDS	
E-7	AVAILABLE OPTIONS FOR SWING CHECK VALVES	



Global Supply Line Australia major Bonney Forge distributor & stockist, supplying world wide.  
Full stock list online [www.globalsupplyline.com.au](http://www.globalsupplyline.com.au)

Contact email: [sales@globalsupplyline.com.au](mailto:sales@globalsupplyline.com.au)

APPLICABLE STANDARDS	
DESIGN	API 602 - ISO 15761 - ASME B16.34
INSPECTION & TESTING	API 598
MARKING	MSS SP-25
RATING	ASME B16.34
FUGITIVE EMISSION	API 624 - ISO 15848

# SWING CHECK VALVES

## BOLTED BONNET SWING CHECK VALVES BASIC CONFIGURATION THREADED AND SOCKET WELD ENDS



WORKING PRESSURE RATING	SIZE		STANDARD DESIGN TYPE	A		B		H		WEIGHT		FIGURE
	NPS	DN		mm	in	mm	in	mm	in	kg	lb	
<b>ASME 800</b>	1/2"	15	S1	80	3.15	9.6	0.4	55	2.17	1.3	2.9	HL 603
	3/4"	20	S1	90	3.54	14	0.6	60	2.36	1.6	3.5	HL 604
	1"	25	S1	110	4.33	18	0.7	78	3.07	2.8	6.2	HL 605
	1-1/2"	40	S1	150	5.91	30	1.2	92	3.62	5.6	12.3	HL 607
	2"	50	S1	180	7.09	36.6	1.4	108	4.25	9	19.8	HL 608
<b>ASME 1500</b>	1/2"	15	S1	90	3.54	9.6	0.4	60	2.36	1.7	3.7	9HL 603
	3/4"	20	S1	110	4.33	14	0.6	78	3.07	3	6.6	9HL 604
	1"	25	S1	127	5.00	18	0.7	88	3.46	4.4	9.7	9HL 605
	1-1/2"	40	S1	180	7.09	30	1.2	108	4.25	10	22.0	9HL 607
<b>ASME 800</b>	1/4"	6	S1	80	3.15	8	0.3	55	2.17	1.4	3.1	H 601
	3/8"	10	S1	80	3.15	9.6	0.4	55	2.17	1.4	3.1	H 602
	1/2"	15	S1	90	3.54	14	0.6	60	2.36	1.6	3.5	H 603
	3/4"	20	S1	110	4.33	18	0.7	78	3.07	3	6.6	H 604
	1"	25	S1	127	5.00	24	0.9	88	3.46	4.3	9.5	H 605
	1-1/4"	32	S1	150	5.91	30	1.2	92	3.62	5.6	12.3	H 606
	1-1/2"	40	S1	180	7.09	36.6	1.4	108	4.25	10	22.0	H 607
<b>ASME 1500</b>	1/2"	15	S1	110	4.33	14	0.6	78	3.07	3.1	6.8	9H 603
	3/4"	20	S1	127	5.00	18	0.7	88	3.46	4.6	10.1	9H 604
	1"	25	S1	150	5.91	24	0.9	92	3.62	6.5	14.3	9H 605
	1-1/4"	32	S1	180	7.09	30	1.2	108	4.25	10.6	23.4	9H 606
	1-1/2"	40	S1	210	8.27	36.6	1.4	145	5.71	19	41.9	9H 607
<b>ASME 2500</b>	1/2"	15	S2	150	5.91	11.5	0.5	128	5.04	7.5	16.5	25HR 603
	3/4"	20	S2	150	5.91	15	0.6	128	5.04	7.5	16.5	25HR 604
	1"	25	S2	210	8.27	19.5	0.8	152	5.98	18.5	40.8	25HR 605
	1-1/2"	40	S2	230	9.06	28	1.1	190	7.48	30	66.1	25HR 607
	2"	50	S2	230	9.06	35	1.4	190	7.48	30	66.1	25HR 608

STANDARD BORE

FULL BORE

BFE reserves the right to change designs, dimensions or specifications without notice.

**PRODUCT FEATURES:**

- Internal Pin Design.

**DESIGN TYPE S1**

**SPIRAL WOUND GASKET BODY-BONNET CONNECTION**

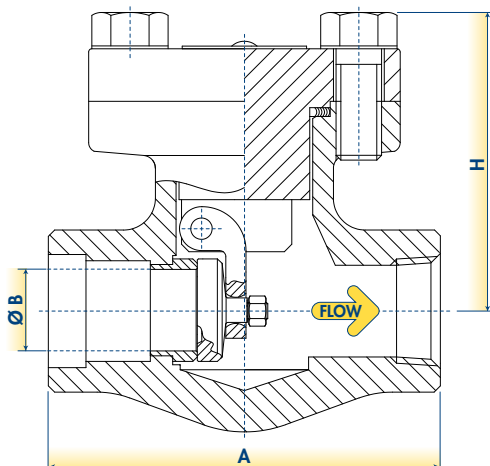

**DESIGN TYPE S2**

**RING JOINT BODY-BONNET CONNECTION**

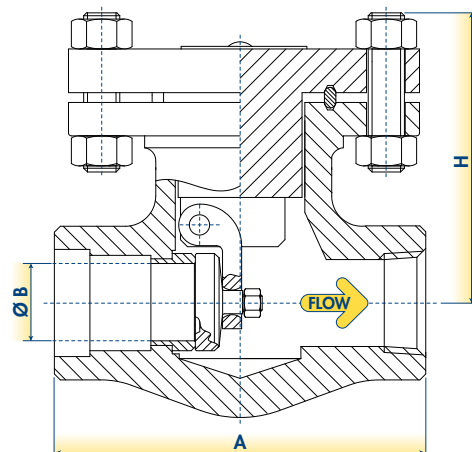

# SWING CHECK VALVES

## BOLTED BONNET SWING CHECK VALVES BASIC CONFIGURATION ASME INTEGRAL FLANGED ENDS



WORKING PRESSURE RATING	SIZE		STANDARD DESIGN TYPE	A-RF		A-RJ		B		H		WEIGHT		FIGURE
	NPS	DN		mm	in	mm	in	mm	in	mm	in	kg	lb	
<b>ASME 150</b>	1/2"	15	S1	108	4.25	N.A.	N.A.	9.6	0.38	75	3.0	2.2	4.9	L1-603
	3/4"	20	S1	117.5	4.63	N.A.	N.A.	14	0.55	75	3.0	3.1	6.8	L1-604
	1"	25	S1	127	5.00	140	5.51	17.5	0.69	85	3.3	4.4	9.7	L1-605
	1-1/2"	40	S1	165	6.50	178	7.01	29.5	1.16	110	4.3	8.3	18.3	L1-607
	2"	50	S1	203	7.99	216	8.50	36.6	1.44	125	4.9	13	28.7	L1-608
<b>ASME 300</b>	1/2"	15	S1	152.5	6.00	163.5	N.A.	9.6	0.38	75	3.0	3.3	7.3	L3-603
	3/4"	20	S1	178	7.01	178	7.01	14	0.55	80	3.1	5.2	11.5	L3-604
	1"	25	S1	216	8.50	216	8.50	17.5	0.69	88	3.5	7.4	16.3	L3-605
	1-1/2"	40	S1	241	9.49	254	10.00	29.5	1.16	115	4.5	13.5	29.8	L3-607
	2"	50	S1	267	10.51	283	11.14	36.6	1.44	130	5.1	19	41.9	L3-608
<b>ASME 600</b>	1/2"	15	S1	165	6.50	163	6.42	9.6	0.38	72	2.8	3.5	7.7	L6-603
	3/4"	20	S1	191	7.52	191	7.52	14	0.55	80	3.1	5.7	12.6	L6-604
	1"	25	S1	216	8.50	216	8.50	17.5	0.69	85	3.3	8	17.6	L6-605
	1-1/2"	40	S1	241	9.49	241	9.49	29.5	1.16	115	4.5	14.5	32.0	L6-607
	2"	50	S1	292	11.50	295	11.61	36.6	1.44	130	5.1	19.5	43.0	L6-608
<b>ASME 150</b>	1/2"	15	S1	108	4.25	N.A.	N.A.	14	0.55	75	3.0	2.8	6.2	1-603
	3/4"	20	S1	117	4.61	N.A.	N.A.	18	0.71	85	3.3	3.6	7.9	1-604
	1"	25	S1	127	5.00	140	5.51	24	0.94	100	3.9	5.2	11.5	1-605
	1-1/2"	40	S1	165	6.50	178	7.01	36.6	1.44	125	4.9	10	22.0	1-607
	2"	50	S1	203	7.99	216	8.50	48	1.89	140	5.5	16	35.3	1-608
<b>ASME 300</b>	1/2"	15	S1	152.5	6.00	N.A.	N.A.	14	0.55	75	3.0	3.6	7.9	3-603
	3/4"	20	S1	178	N.A.	178	N.A.	18	0.71	90	3.5	6.4	14.1	3-604
	1"	25	S1	216	8.50	229	9.02	24	0.94	100	3.9	8.2	18.1	3-605
	1-1/2"	40	S1	241	9.49	254	10.00	36.6	1.44	120	4.7	15	33.1	3-607
	2"	50	S1	267	10.51	283	11.14	48	1.89	150	5.9	21	46.3	3-608
<b>ASME 600</b>	1/2"	15	S1	165	6.50	163	6.42	14	0.55	75	3.0	3.8	8.4	6-603
	3/4"	20	S1	191	7.52	191	7.52	18	0.71	90	3.5	6.5	14.3	6-604
	1"	25	S1	216	8.50	216	8.50	24	0.94	100	3.9	8.5	18.7	6-605
	1-1/2"	40	S1	241	9.49	241	9.49	36.6	1.44	120	4.7	16	35.3	6-607
	2"	50	S1	292	11.50	295	11.61	48	1.89	150	5.9	23	50.7	6-608
<b>ASME 1500</b>	1/2"	15	S1	216	8.50	216	8.50	14	0.55	105	4.1	7.5	16.5	15F 603
	3/4"	20	S1	229	9.02	229	9.02	18	0.71	125	4.9	11.2	24.7	15F 604
	1"	25	S1	254	10.00	254	10.00	24	0.94	135	5.3	14.5	32.0	15F 605
	1-1/2"	40	S1	305	12.01	305	12.01	36.6	1.44	155	6.1	26.5	58.4	15F 607
	2"	50	S1	368	14.49	371	14.61	48	1.89	195	7.7	50	110.2	15F 608
<b>ASME 2500</b>	1/2"	15	S2	264	10.39	264	10.39	11.5	0.45	128	5.0	14.3	31.5	25RF 603
	3/4"	20	S2	273	10.75	273	10.75	15	0.59	130	5.1	16	35.3	25RF 604
	1"	25	S2	308	12.13	308	12.13	19.5	0.77	152	6.0	26.3	58.0	25RF 605
	1-1/2"	40	S2	384	15.12	387	15.24	28	1.10	188	7.4	54	119.0	25RF 607
	2"	50	S2	451	17.76	454	17.87	35	1.38	190	7.5	56	123.5	25RF 608

STANDARD BORE

FULL BORE

BFE reserves the right to change designs, dimensions or specifications without notice.

### PRODUCT FEATURES:

- Internal Pin Design.
- Integral body flanges.

### DESIGN TYPE S1

#### SPIRAL WOUND GASKET BODY-BONNET CONNECTION

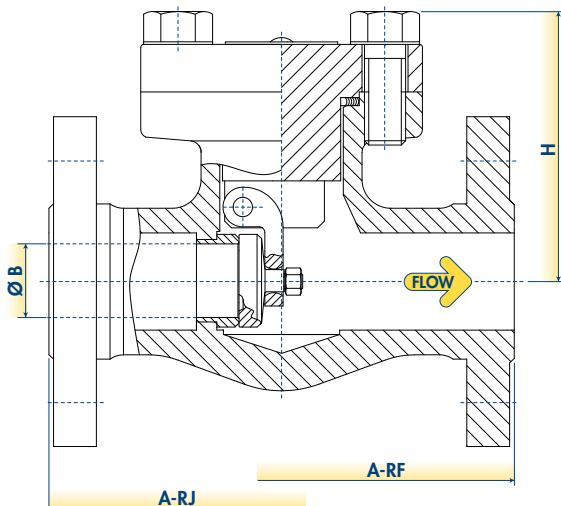

### DESIGN TYPE S2

#### RING JOINT BODY-BONNET CONNECTION

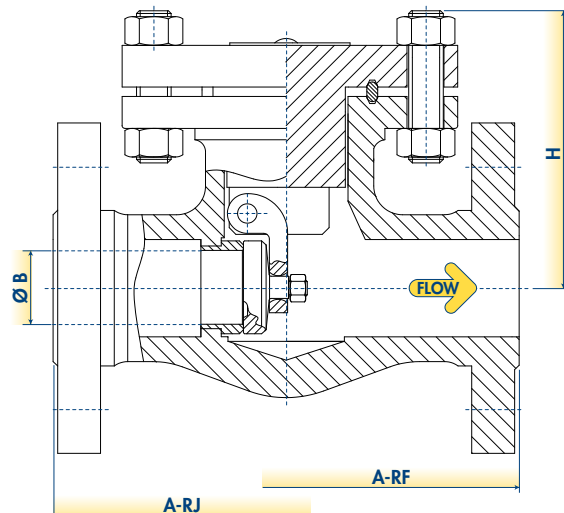



# SWING CHECK VALVES

## WELDED BONNET SWING CHECK VALVES BASIC CONFIGURATION THREADED AND SOCKET WELD ENDS



WORKING PRESSURE RATING	SIZE		STANDARD DESIGN TYPE	A		B		H		WEIGHT		FIGURE		
	NPS	DN		mm	in	mm	in	mm	in	kg	lb			
<b>ASME 800</b>	1/2"	15	W3	80	3.15	9.6	0.4	54	2.13	0.9	2.0	HWL 603	<b>STANDARD BORE</b>	
	3/4"	20	W3	90	3.54	14	0.6	60	2.36	1.1	2.4	HWL 604		
	1"	25	W3	110	4.33	18	0.7	76	2.99	2.3	5.1	HWL 605		
	1-1/2"	40	W3	150	5.91	30	1.2	92	3.62	5	11.0	HWL 607		
	2"	50	W3	127	5.00	36.6	1.4	110	4.33	8.3	18.3	HWL 608		
<b>ASME 1500</b>	1/2"	15	W3	90	3.54	9.6	0.4	54	2.13	1.4	3.1	9HWL 603		
	3/4"	20	W3	110	4.33	14	0.6	76	2.99	2.2	4.9	9HWL 604		
	1"	25	W3	127	5.00	18	0.7	86	3.39	3	6.6	9HWL 605		
	1-1/2"	40	W3	180	7.09	30	1.2	110	4.33	9.6	21.2	9HWL 607		
	2"	50	W3	210	8.27	36.6	1.4	150	5.91	16	35.3	9HWL 608		
<b>ASME 800</b>	1/4"	6	W3	80	3.15	8	0.3	55	2.17	1	2.2	HW 601		<b>FULL BORE</b>
	3/8"	10	W3	80	3.15	9.6	0.4	55	2.17	1	2.2	HW 602		
	1/2"	15	W3	90	3.54	14	0.6	60	2.36	1.2	2.6	HW 603		
	3/4"	20	W3	110	4.33	18	0.7	78	3.07	2.3	5.1	HW 604		
	1"	25	W3	127	5.00	24	0.9	88	3.46	3.3	7.3	HW 605		
	1-1/4"	32	W3	150	5.91	30	1.2	92	3.62	5.2	11.5	HW 606		
	1-1/2"	40	W3	180	7.09	36.6	1.4	110	4.33	8.7	19.2	HW 607		
	2"	50	W3	210	8.27	48	1.9	150	5.91	14	30.9	HW 608		
<b>ASME 1500</b>	1/4"	6	W3	90	3.54	8	0.3	55	2.17	1.4	3.1	9HW 601		
	3/8"	10	W3	90	3.54	9.6	0.4	55	2.17	1.4	3.1	9HW 602		
	1/2"	15	W3	110	4.33	14	0.6	76	2.99	2.5	5.5	9HW 603		
	3/4"	20	W3	127	5.00	18	0.7	84	3.31	3.7	8.2	9HW 604		
	1"	25	W3	127	5.00	24	0.9	90	3.54	6	13.2	9HW 605		
	1-1/4"	32	W3	127	5.00	30	1.2	110	4.33	10	22.0	9HW 606		
	1-1/2"	40	W3	210	8.27	36.6	1.4	150	5.91	15.5	34.2	9HW 607		
	2"	50	W3	230	9.06	48	1.9	230	9.06	22	48.5	9HW 608		
<b>ASME 2500</b>	1/4"	6	W3	110	4.33	8	0.3	70	2.76	3.2	7.1	25HW 601		
	3/8"	10	W3	110	4.33	8	0.3	70	2.76	3.2	7.1	25HW 602		
	1/2"	15	W3	127	5.00	11.5	0.5	86	3.39	3.8	8.4	25HW 603		
	3/4"	20	W3	127	5.00	15	0.6	92	3.62	5.6	12.3	25HW 604		
	1"	25	W3	127	5.00	19.5	0.8	110	4.33	10	22.0	25HW 605		
	1-1/4"	32	W3	127	5.00	25	1.0	130	5.12	13	28.7	25HW 606		
	1-1/2"	40	W3	210	8.27	28	1.1	150	5.91	16	35.3	25HW 607		
	2"	50	W3	230	9.06	38	1.5	180	7.09	21	46.3	25HW 608		

BFE reserves the right to change designs, dimensions or specifications without notice.

### PRODUCT FEATURES:

- Internal Pin Design.
- Body-Bonnet weld to ASME IX.

### DESIGN TYPE W3 FULL PENETRATION WELD BODY-BONNET CONNECTION

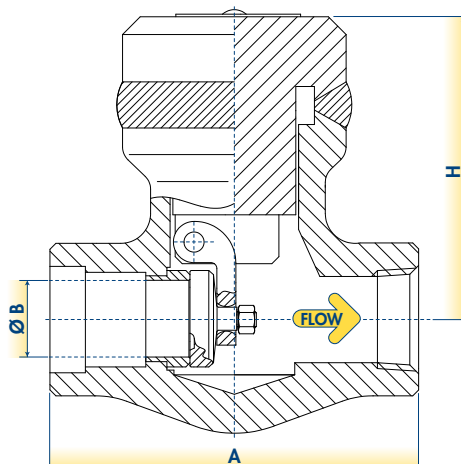

## WELDED BONNET SWING CHECK VALVES BASIC CONFIGURATION ASME INTEGRAL FLANGED ENDS



WORKING PRESSURE RATING	SIZE		STANDARD DESIGN TYPE	A-RF		A-RJ		B		H		WEIGHT		FIGURE
	NPS	DN		mm	in	mm	in	mm	in	mm	in	kg	lb	
<b>ASME 150</b>	1/2"	15	W3	108	4.25	N.A.	N.A.	9.6	0.38	75	3.0	2.1	4.6	1HWL 603
	3/4"	20	W3	117.5	4.63	N.A.	N.A.	14	0.55	75	3.0	2.9	6.5	1HWL 604
	1"	25	W3	127	5.00	140	5.51	17.5	0.69	85	3.3	4.2	9.2	1HWL 605
	1-1/2"	40	W3	165	6.50	178	7.01	29.5	1.16	110	4.3	7.9	17.4	1HWL 607
	2"	50	W3	203	7.99	216	8.50	36.6	1.44	125	4.9	12.4	27.2	1HWL 608
<b>ASME 300</b>	1/2"	15	W3	152.5	6.00	163.5	N.A.	9.6	0.38	75	3.0	3.1	6.9	3HWL 603
	3/4"	20	W3	178	7.01	178	7.01	14	0.55	80	3.1	4.9	10.9	3HWL 604
	1"	25	W3	216	8.50	216	8.50	17.5	0.69	88	3.5	7.0	15.5	3HWL 605
	1-1/2"	40	W3	241	9.49	254	10.00	29.5	1.16	115	4.5	12.8	28.3	3HWL 607
	2"	50	W3	267	10.51	283	11.14	36.6	1.44	130	5.1	18.1	39.8	3HWL 608
<b>ASME 600</b>	1/2"	15	W3	165	6.50	163	6.42	9.6	0.38	72	2.8	3.3	7.3	6HWL 603
	3/4"	20	W3	191	7.52	191	7.52	14	0.55	80	3.1	5.4	11.9	6HWL 604
	1"	25	W3	216	8.50	216	8.50	17.5	0.69	85	3.3	7.6	16.8	6HWL 605
	1-1/2"	40	W3	241	9.49	241	9.49	29.5	1.16	115	4.5	13.8	30.4	6HWL 607
	2"	50	W3	292	11.50	295	11.61	36.6	1.44	130	5.1	18.5	40.8	6HWL 608
<b>ASME 150</b>	1/2"	15	W3	108	4.25	N.A.	N.A.	14	0.55	75	3.0	2.7	5.9	1HW 603
	3/4"	20	W3	117	4.61	N.A.	N.A.	18	0.71	85	3.3	3.4	7.5	1HW 604
	1"	25	W3	127	5.00	140	5.51	24	0.94	100	3.9	4.9	10.9	1HW 605
	1-1/2"	40	W3	165	6.50	178	7.01	36.6	1.44	125	4.9	9.5	20.9	1HW 607
	2"	50	W3	203	7.99	216	8.50	48	1.89	140	5.5	15.2	33.5	1HW 608
<b>ASME 300</b>	1/2"	15	W3	152.5	6.00	N.A.	N.A.	14	0.55	75	3.0	3.4	7.5	3HW 603
	3/4"	20	W3	178	N.A.	178	N.A.	18	0.71	90	3.5	6.1	13.4	3HW 604
	1"	25	W3	216	8.50	229	9.02	24	0.94	100	3.9	7.8	17.2	3HW 605
	1-1/2"	40	W3	241	9.49	254	10.00	36.6	1.44	120	4.7	14.3	31.4	3HW 607
	2"	50	W3	267	10.51	283	11.14	48	1.89	150	5.9	20.0	44.0	3HW 608
<b>ASME 600</b>	1/2"	15	W3	165	6.50	163	6.42	14	0.55	75	3.0	3.6	8.0	6HW 603
	3/4"	20	W3	191	7.52	191	7.52	18	0.71	90	3.5	6.2	13.6	6HW 604
	1"	25	W3	216	8.50	216	8.50	24	0.94	100	3.9	8.1	17.8	6HW 605
	1-1/2"	40	W3	241	9.49	241	9.49	36.6	1.44	120	4.7	15.2	33.5	6HW 607
	2"	50	W3	292	11.50	295	11.61	48	1.89	150	5.9	21.9	48.2	6HW 608
<b>ASME 1500</b>	1/2"	15	W3	216	8.50	216	8.50	14	0.55	105	4.1	7.1	15.7	15HWF 603
	3/4"	20	W3	229	9.02	229	9.02	18	0.71	125	4.9	10.6	23.5	15HWF 604
	1"	25	W3	254	10.00	254	10.00	24	0.94	135	5.3	13.8	30.4	15HWF 605
	1-1/2"	40	W3	305	12.01	305	12.01	36.6	1.44	155	6.1	25.2	55.5	15HWF 607
	2"	50	W3	368	14.49	371	14.61	48	1.89	195	7.7	47.5	104.7	15HWF 608
<b>ASME 2500</b>	1/2"	15	W3	264	10.39	264	10.39	11.5	0.45	128	5.0	13.6	29.9	25HWF 603
	3/4"	20	W3	273	10.75	273	10.75	15	0.59	130	5.1	15.2	33.5	25HWF 604
	1"	25	W3	308	12.13	308	12.13	19.5	0.77	152	6.0	25.0	55.1	25HWF 605
	1-1/2"	40	W3	384	15.12	387	15.24	28	1.10	188	7.4	51.3	113.1	25HWF 607
	2"	50	W3	451	17.76	454	17.87	35	1.38	190	7.5	53.2	117.3	25HWF 608

STANDARD BORE

FULL BORE

BFC reserves the right to change designs, dimensions or specifications without notice.

### PRODUCT FEATURES:

- Internal Pin Design.
- Body-Bonnet weld to ASME IX.
- Integral body flanges.

### DESIGN TYPE W3 FULL PENETRATION WELD BODY-BONNET CONNECTION

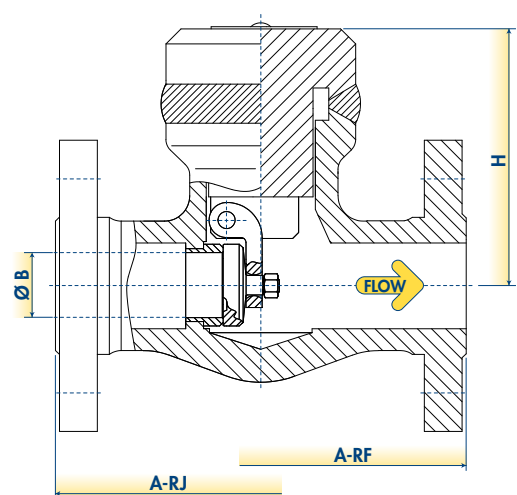

# SWING CHECK VALVES

## AVAILABLE OPTIONS FOR SWING CHECK VALVES OTHER VALVE OPTIONS OR CUSTOMISED VERSIONS ARE AVAILABLE ON REQUEST, CONTACT BFE FOR SPECIAL REQUIREMENTS.

### TILTING DISC

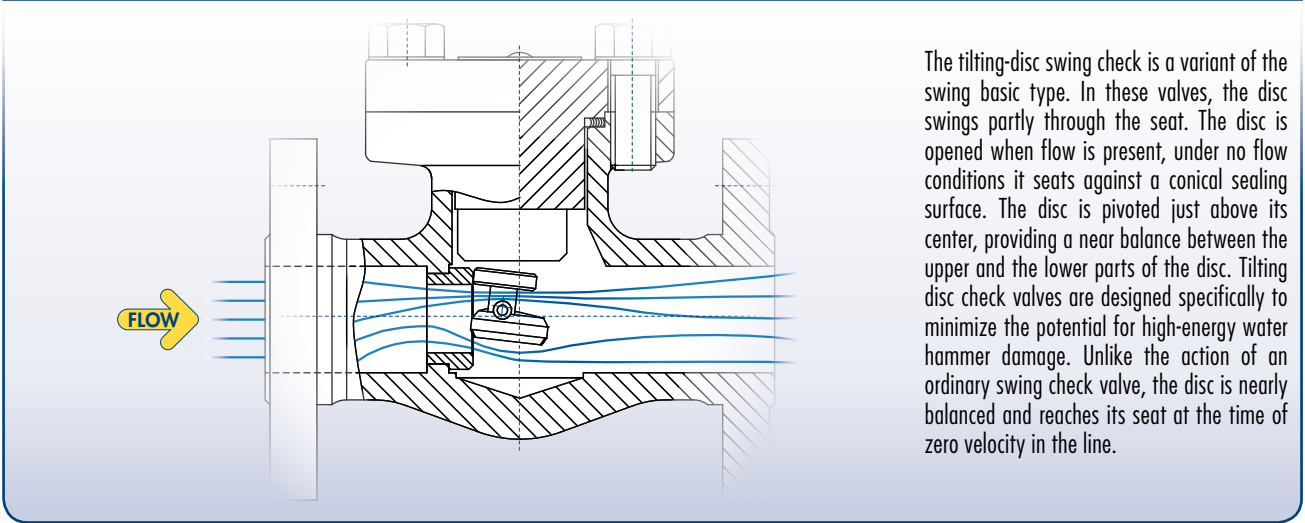

The tilting-disc swing check is a variant of the swing basic type. In these valves, the disc swings partly through the seat. The disc is opened when flow is present, under no flow conditions it seats against a conical sealing surface. The disc is pivoted just above its center, providing a near balance between the upper and the lower parts of the disc. Tilting disc check valves are designed specifically to minimize the potential for high-energy water hammer damage. Unlike the action of an ordinary swing check valve, the disc is nearly balanced and reaches its seat at the time of zero velocity in the line.

### ALTERNATIVE CLOSURE MEMBER ANTI-LOOSENING SYSTEM

Swing check design must prevent possible unscrewing of the swing check closure member nut. BFE standard design achieves this goal is by cold upsetting of the closure member nut connection. Alternative solutions are available as an option, the most common alternative solution is obtained by an additional wire or pin that prevent loosening in service.

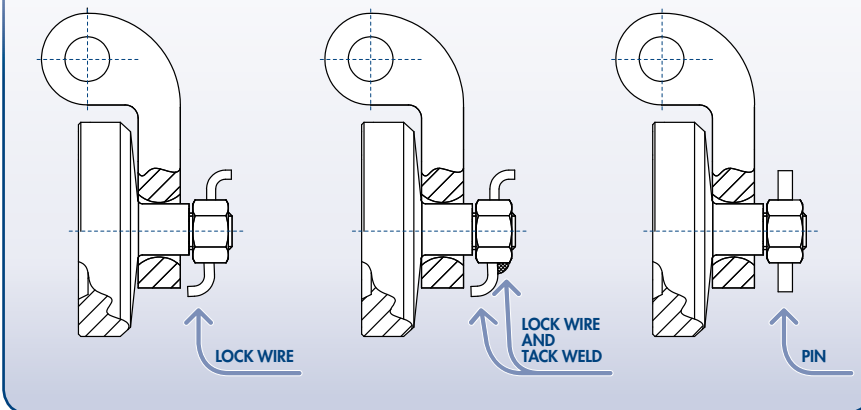

### SPECIAL END FINISH

The choice of end connections for connecting a valve to its associated pipe is performed by customers. Common end finish stated in the catalogue are socket, threaded, flanged (RF or RJ) and butt-weld ends. BFE is basically able to perform any end finish as per customer request, special end finish. Other end finish as follows: hub, compact flange, any ASME B16.5 end finish other than RF and RJ, etc.

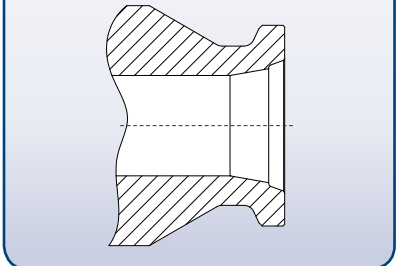

### SOFT SEATED TRIM

In applications that require positive shut-off such as in chemical and petrochemical services, soft-seated swing check valve is a suitable solution because the use of soft-seat materials imparts excellent sealing ability. Soft seat inserts provide the necessary soft-seating to improve the leakproof design. Soft Insert can be obtained on the seat or on the closure member.

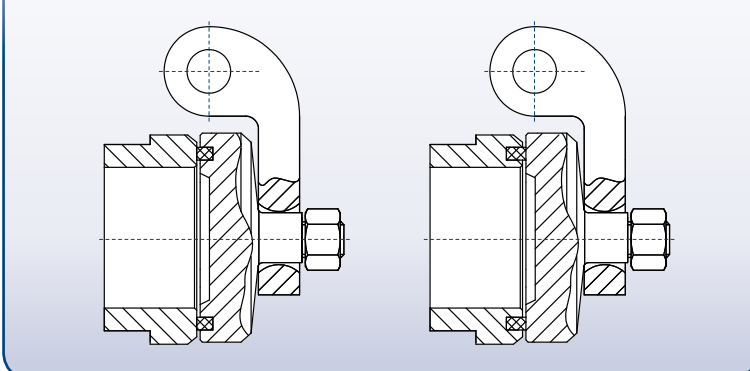

### WEEP HOLE

The weep hole, is a small opening that allows the fluid to drain from the downstream side to the upstream in case of closed valve. Purpose of weep hole can depend from the application. In case of weep hole option the valve does not achieve leak-tight closing or keep the differential pressure.

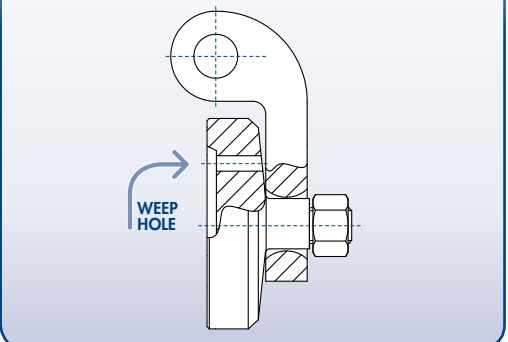

## AVAILABLE OPTIONS FOR SWING CHECK VALVES

OTHER VALVE OPTIONS OR CUSTOMISED VERSIONS ARE AVAILABLE ON REQUEST, CONTACT BFE FOR SPECIAL REQUIREMENTS.

### TIE ROD PACKAGING SET

A tie rod is a slender structural unit used as a tie and (in most applications) capable of carrying tensile loads only. Tie Rod Packaging is used to help protect trim of check valves during shipment. It is common for a transport package to be dropped, kicked, and impacted: These events may produce potentially damaging shocks of the seal surfaces. Shock and vibration are controlled by the tie rod geometry that block the closure member in open position so that the chance of product damage is greatly reduced. The soft insert can be manufactured from elastomer, polymers and similar resilient or semi-resilient materials.

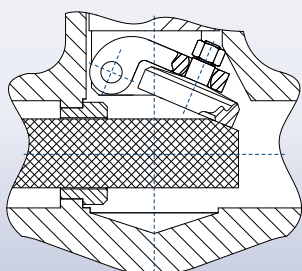

### AUXILIARY STANDARD DRAIN

Swing check valves can be furnished with drain. Standard drain connections consist of a drilled, tapped, and plugged hole at the ASME B16.34 "G" location. Other types of drains, including welding, or threaded nipples, can also be furnished when specified.

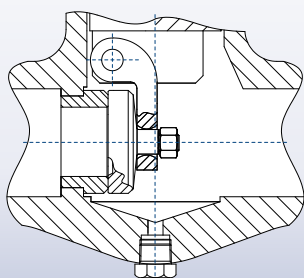

### EYEBOLT FOR HANDLING

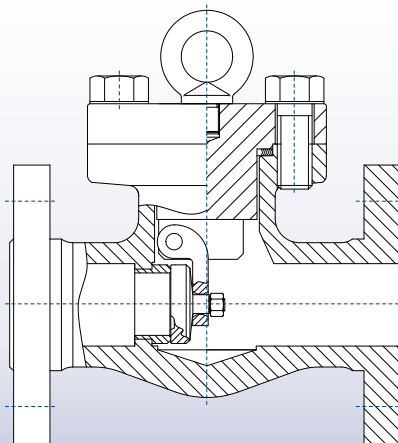

Small size swing check valves does not require lifting eyebolts as standard because of the low weight. Handling is normally performed on small valves by lifting with eye bolts or rods through flange holes. If required the bonnet design can be modified in order to include one screwed lifting eye bolts screwed on the top to facilitate valve installation into the piping system.

### SPECIAL DRAIN OR VENT LINE

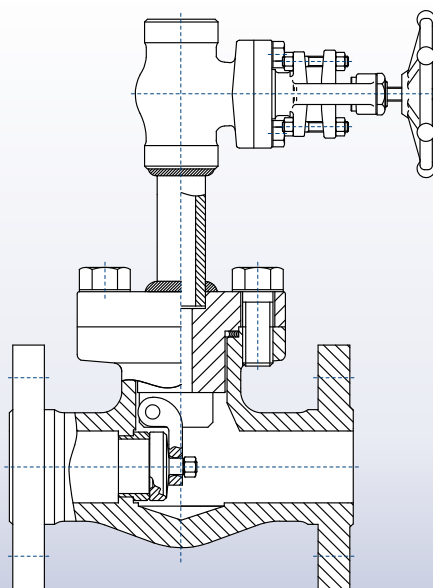

The removal of fluid in pipelines can be a frequent operation for some oil&gas industry applications. The drain/vent line can be added to the swing check design based on the customer requirements. Connections can be provided with permanent block valves, including plugs or blinds.

### LOW FLOW RATE NON-RETURN VALVE

Special design and material selection can be performed to eliminate valve chattering. This is a common problem with valves operating in or around the flow-rate and fluid specific mass range the valve is designed to open at. In systems using conventional valves, oscillation caused harmonics in the system create problems related to noise, damage to the valve seats, localized air bubbles etc. Special design based on the flow operating conditions and proper low density material selection eliminate chatter problems.

